



ASSEMBLY  
INSTRUCTIONS









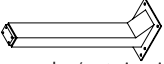
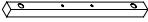

---

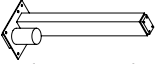
INSTRUCTIONS  
D'ASSEMBLAGE

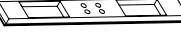
---

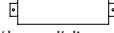
INSTRUCCIONES DE  
ENSAMBLAJE

HARDWARES / QUINCAILLERIES / QUINCALLAS

CODE / CÓDIGO	QTY / QTÉ / CANT.	CODE / CÓDIGO	QTY / QTÉ / CANT.	CODE / CÓDIGO	QTY / QTÉ / CANT.	CODE / CÓDIGO	QTY / QTÉ / CANT.
PA-1000-A  Left leg / patte gauche / pata izquierda	1	PA-1000-E  Arm support / bras de support / brazo de soporte	2	PA-1000-K  (25 mm) washer / rondelle / arandela	8	PA-1000-P  (2,5 mm)	1
PA-1000-B  Right leg / patte droite / pata derecha	1	PA-1000-G  Transversale bar / barre transversale / barra transversal	2	PA-1000-L  (30 mm) Pre-installed / Pré-installé / Pre - instalado	8	<b>For future installation / Pour installation futur Para instalaciones futuro</b>	
PA-1000-C  Foot / pied / pie	2	PA-1000-I  Drive shaft / Arbre de transmission / El eje de accionamiento	1	PA-1000-M  (4 mm) Pre-installed / Pré-installé / Pre - instalado	4	PA-1000-Q  Power supplie/ barre d'alimentation / barra de poder	1
PA-1000-D  Pre-installed / Pré-installé / Pre - instalado Leg leveler/ patte ajustable/ pata ajustable	4	PA-1000-J  (10 mm)	12	PA-1000-O  (5 mm)	1	PA-1000-R  Control/ contrôle/control	1

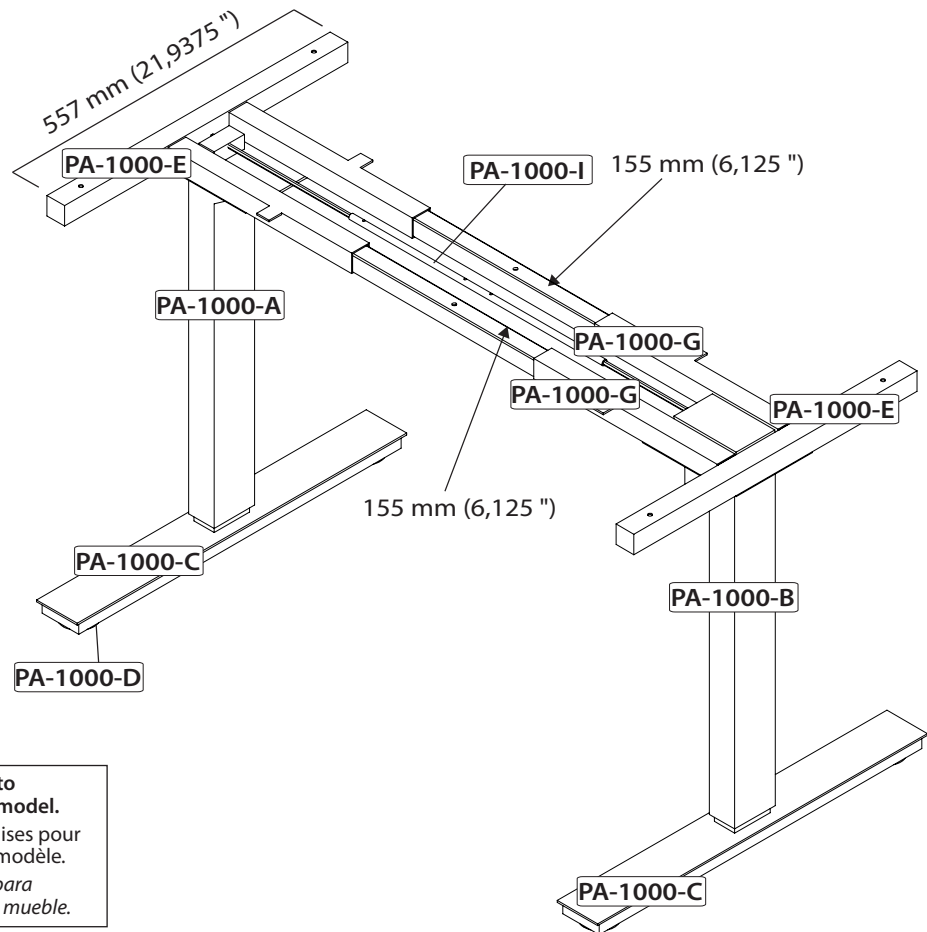

two people are required to assemble and move this model.  
deux personnes sont requises pour assembler et déplacer ce modèle.  
se necesitan dos personas para ensamblar y desplazar este mueble.

**IMPORTANT / IMPORTANTE**

- To reset the motor: 1- Press and hold the two arrows simultaneously until you hear a "BEEP" sound. (PA-1000-R)  
2- Bring down the table to the lowest level, you should hear three "BEEP" sound.  
3- Your table is ready for use.**

Pour réinitialiser le moteur: 1- Appuyez et maintenez les 2 flèches en même temps jusqu'à entendre un "BIP" sonore. (PA-1000-R)  
2-Descendez la table à son plus bas niveau, vous devriez entendre trois "BIP" sonore.  
3- Votre table est prête à être utilisé.

Para restablecer el motor: 1- Pulse y mantenga las dos flechas al mismo tiempo hasta que escuche un sonido "BIP". ( PA-1000-R )  
2- Descender la mesa al nivel más bajo, usted debe escuchar el sonido de tres "BIP".  
3- Su mesa está lista para su uso.

**LEFT LEG ASSEMBLY / ASSEMBLAGE PATTE GAUCHE / ASSEMBLAGE PATA IZQUIERDA**

**assemble upside down**

**assemblez en position renversée**

**realice el ensamblaje en posición invertida**

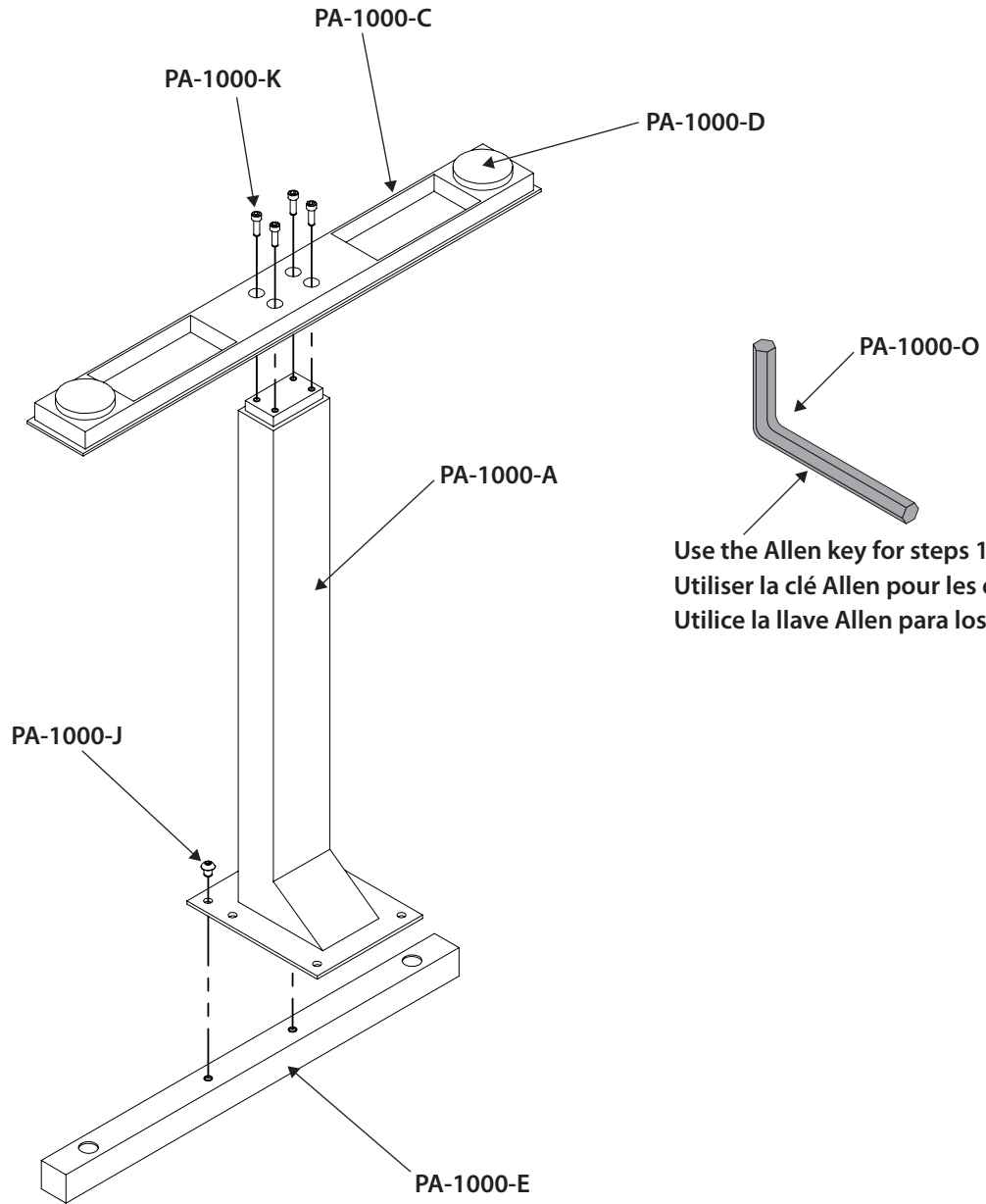



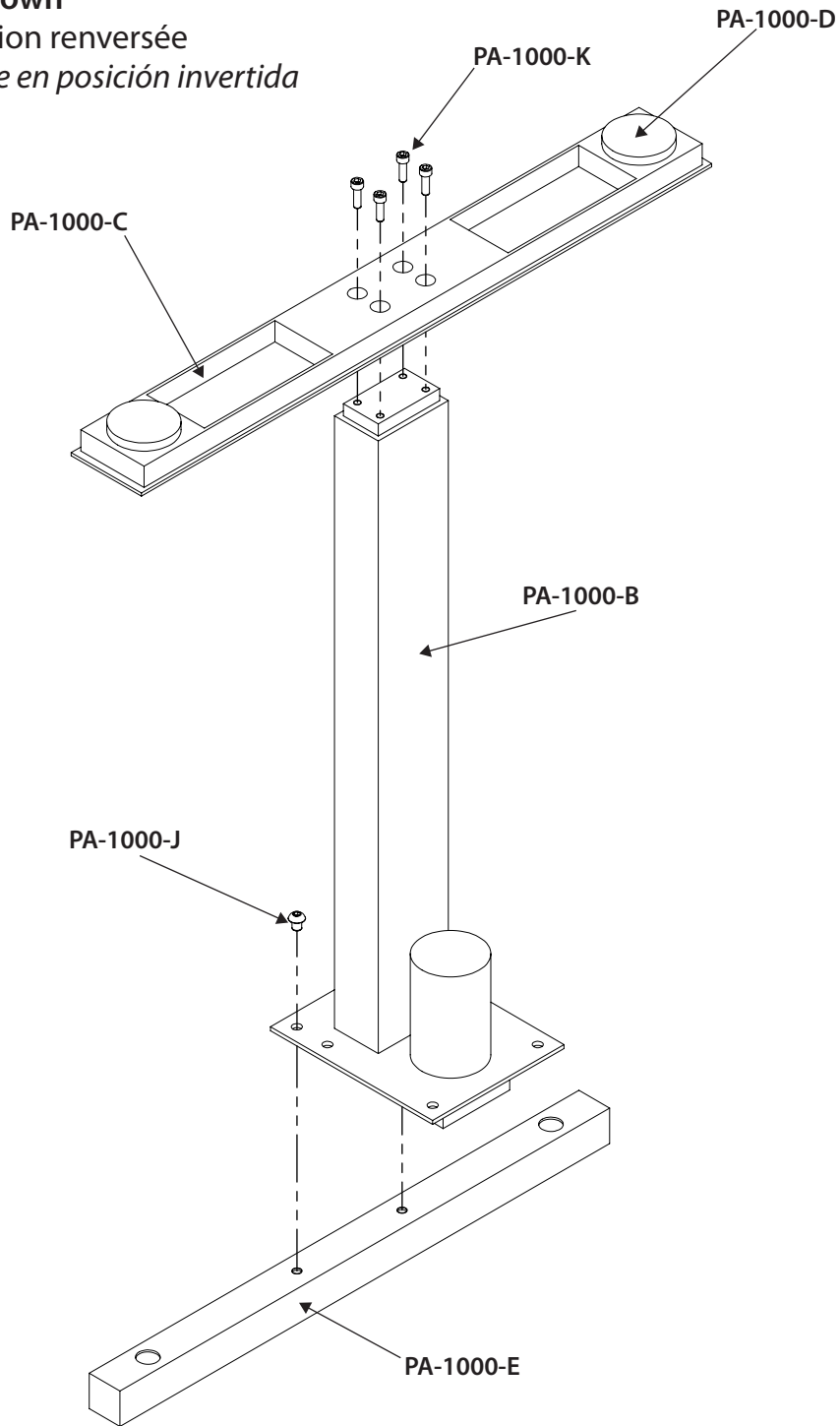

Code / Código	PA-1000-A	PA-1000-C	PA-1000-D	PA-1000-E	PA-1000-J	washer / rondelle / arandela	PA-1000-O
Qty / Qté / Cant.	x 1	x 1	x 2	x 1	x 2	x 4	x 1

**RIGHT LEG ASSEMBLY / ASSEMBLAGE PATTE DROITE / ASSEMBLAGE PATA DERECHA**

**assemble upside down**  
*assemblez en position renversée*  
*realice el ensamblaje en posición invertida*

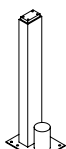
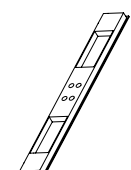

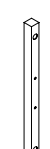
Code / Código	PA-1000-B	PA-1000-C	PA-1000-D	PA-1000-E	PA-1000-J	PA-1000-K
Qty / Qté / Cant.	x 1	x 1	x 2	x 1	x 2	x 4

washer / rondelle / arandela

**LEG ASSEMBLED TO TOP SUPPORT / ASSEMBLAGE DES PATTES AU SUPPORT /  
CÓMO ARMAR LAS PATAS DE APOYO**

**assemble upside down**  
*assemblez en position renversée*  
*realice el ensamblaje en posición invertida*

**IMPORTANT / IMPORTANTE**

- 1- Install the 2 legs
  - 2- Slightly loosen the 8 PA-1000-L
  - 3- Extend base to desired length
- 1- Installer les 2 pattes
- 2- Desserrer un peu les 8 PA-1000-L
- 3- Étirer la base à la longueur désirée
- 1- Instalar las 2 patas
- 2- Afloje ligeramente la 8 PA-1000-L
- 3- extender la base a la longitud deseada

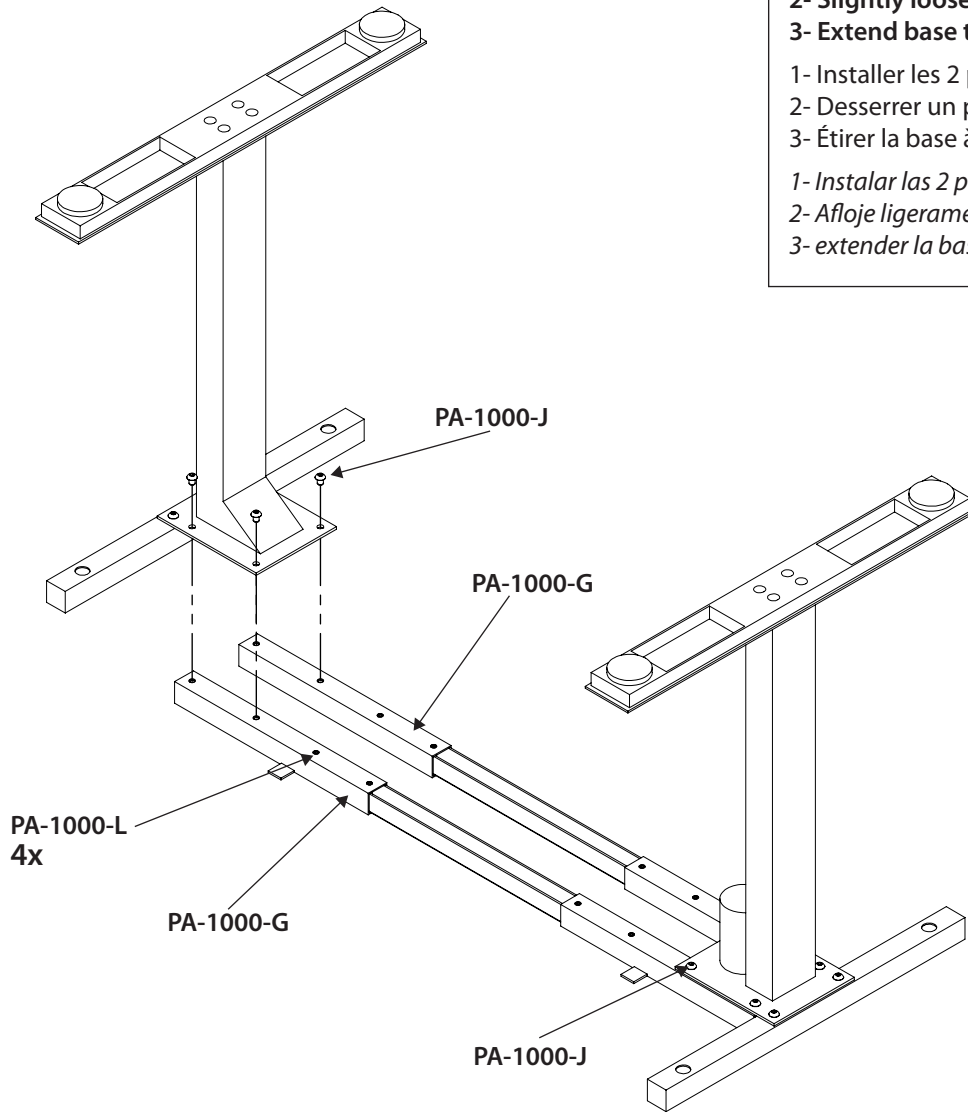

3



Code / Código	PA-1000-G	PA-1000-J	PA-1000-L
Qty / Qté / Cant.	x 2	x 8	x 8

**ADJUSTING THE STRUCTURE**  
**AJUSTEMENT DE LA STRUCTURE**  
**AJUSTE DE LA ESTRUCTURA**

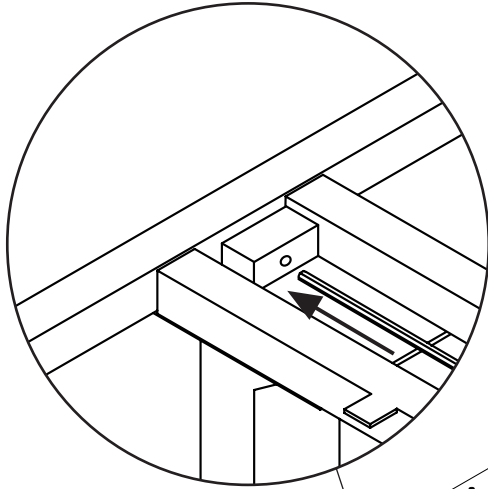

**IMPORTANT / IMPORTANTE**

1- Unscrew PA-1000-M (x4)  
 1- Dévisser PA-1000-M (x4)  
 1- Desatornillar PA-1000-M (x4)

2- Pull to extend PA-1000-I  
 2- Tirer pour allonger PA-1000-I  
 2- Tira de extender PA-1000-I

3- Screw PA-1000-M (x2)  
 3- Visser PA-1000-M (x2)  
 3- Atornillar PA-1000-M (x2)

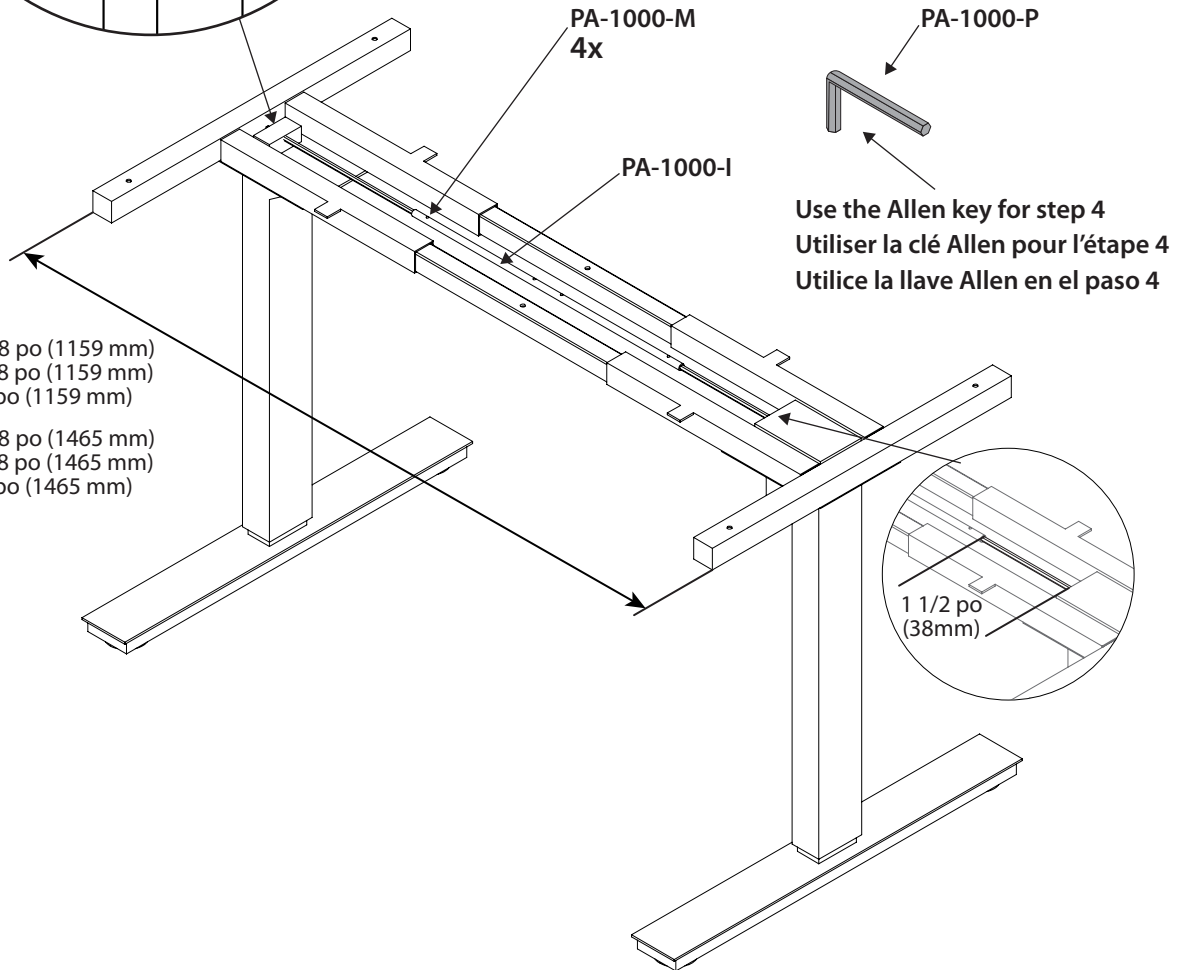

For the 48": 45 5/8 po (1159 mm)  
 Pour le 48": 45 5/8 po (1159 mm)  
 A los 48": 45 5/8 po (1159 mm)

For the 60": 57 5/8 po (1465 mm)  
 Pour le 60": 57 5/8 po (1465 mm)  
 A los 60": 57 5/8 po (1465 mm)

4

	pre-assembled Pré-assemblé Pre ensamblado			
Code / Código	PA-1000-M	PA-1000-I	PA-1000-P	
Qty / Qté / Cant.	x 4	x 1	x 1	