

CHOCOLATE : CHOCOLAT : *CHOCOLATE*

BARK GREY : GRIS ÉCORCE : *CORTEZA GRIS*

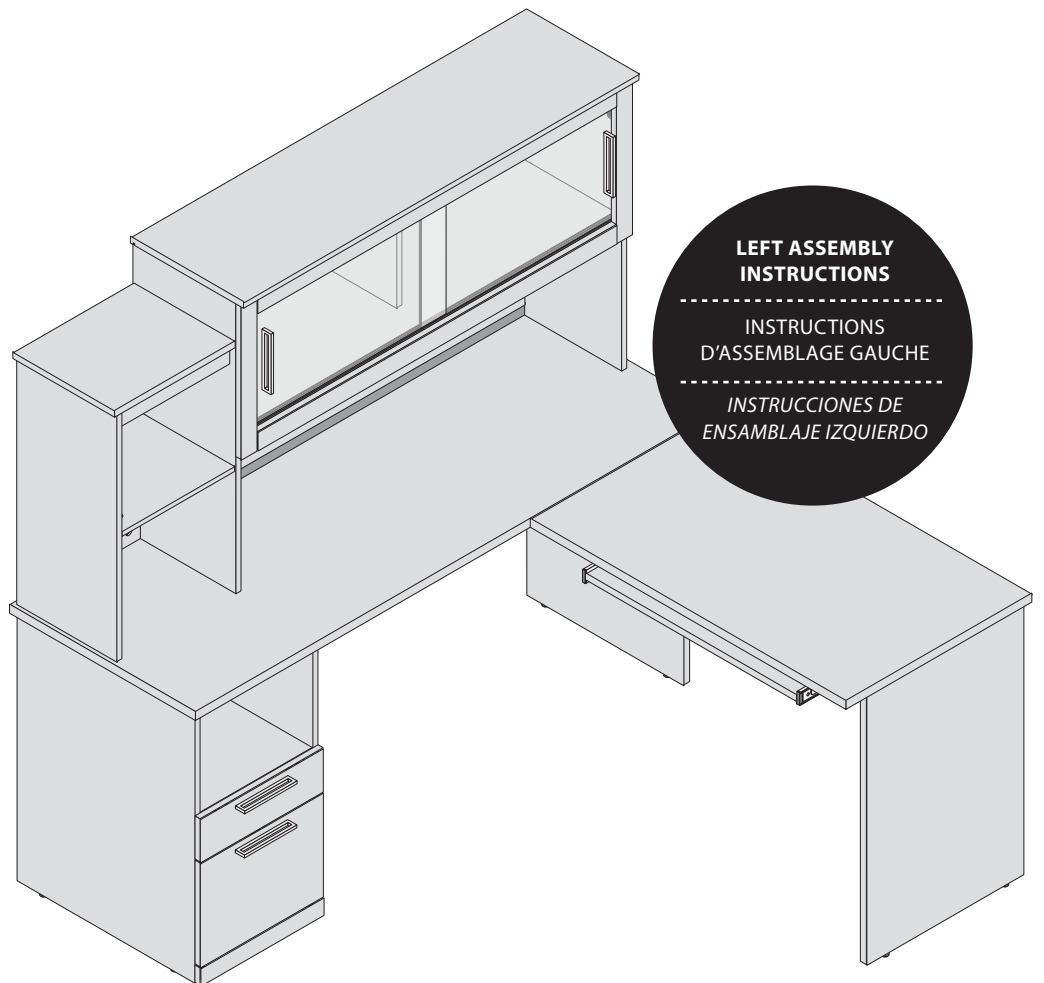

**LEFT ASSEMBLY
INSTRUCTIONS**

INSTRUCTIONS
D'ASSEMBLAGE GAUCHE

INSTRUCCIONES DE
ENSAMBLAJE IZQUIERDO

PARTS / PIÈCES / PIEZAS

CODE / CÓDIGO / PIEZAS	QTY / QTÉ / CANT.	CODE / CÓDIGO / PIEZAS	QTY / QTÉ / CANT.	CODE / CÓDIGO / PIEZAS	QTY / QTÉ / CANT.	CODE / CÓDIGO / PIEZAS	QTY / QTÉ / CANT.
CA01A	2	37	1	66	1	83	1
CA05A	2	40	1	67	1	84	1
CA09A	2	TC40C	1	70	1	85	1
CA13A	2	41	1	71	1	glass / vitre / vidrio 23 15/16" x 14 1/2" (608 x 368 mm)	2
17	1	42	1	72	1	74 back panel / dos / panel trasero 47 5/8" x 15 3/4" (1210 mm x 401 mm)	1
18	1	43	1	75	1	CA15A bottom / fond / fondo 15 3/8" x 12 1/2" (391 mm x 316 mm)	2
20	1	44	1	76	1	90 Extrusion grommet / Extrusion passe-fil / Pasacables extrusión	1
33	2	45	1	80	2		
34	1	47	1	81	1		
35	1	48	1	82	1		

tools required
outils requis
herramientas necesarias

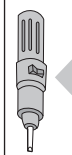
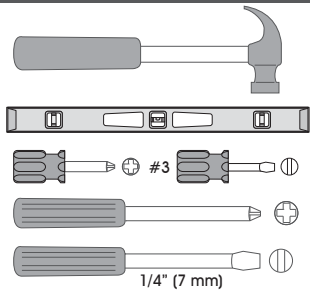

the use of electric tools must be made with vigilance.

l'utilisation d'outils électriques doit être faite avec vigilance.

las herramientas eléctricas deben utilizarse con sumo cuidado.









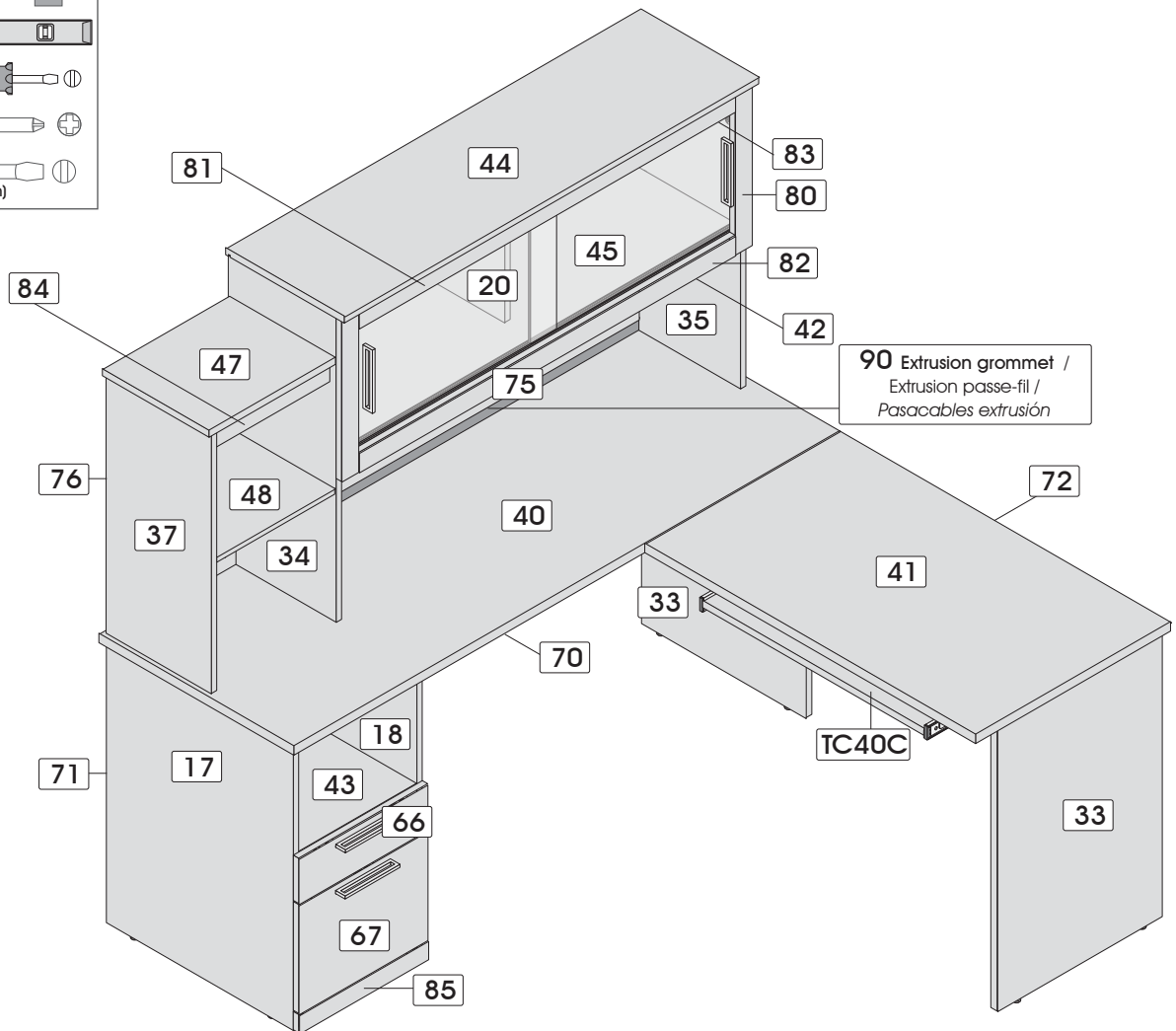





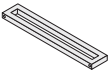





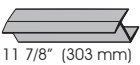
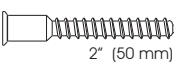

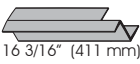

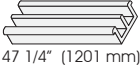
two people are required to assemble and move this model.

deux personnes sont requises pour assembler et déplacer ce modèle.

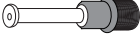

se necesitan dos personas para ensamblar y desplazar este mueble.

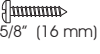
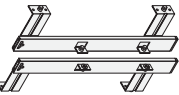

HARDWARE / QUINCAILLERIES / QUINCALLA

CODE / CÓDIGO / PIEZAS	QTY / QTÉ / CANT.	CODE / CÓDIGO / PIEZAS	QTY / QTÉ / CANT.	CODE / CÓDIGO / PIEZAS	QTY / QTÉ / CANT.	CODE / CÓDIGO / PIEZAS	QTY / QTÉ / CANT.
CA-77	 10	EC-744	 4	PO-778	 4	VF-997	 Plastic Plastique Plástico 4
CA-99	 49	EQ-143	 2	TI-552	 3	RO-998	 4
CA-100	 4	EX-681	 2 11 7/8" (303 mm)	VC-204	 4 2" (50 mm)		
CA-101	 4	EX-702	 2 16 3/16" (411 mm)	VE-244	 3/8" (10 mm) 12		
CA-103	 4	EX-830	 2 47 1/4" (1201 mm)	VF-232	 7/8" (22 mm) 4		
CL-140	 -	H-03	 63	VM-601	 3/4" (20 mm) 4		
CL-745	 1	H-36	 60	VR-207	 1/2" (13 mm) 12		
CO-249	runners 406 mm (16") coulisseaux 406 mm corredoras 406 mm 2	PA-844	 8 1" (25 mm)	VR-210	 5/8" (16 mm) 8		
CO-843	 1			VR-212	 1" (25 mm) 24		

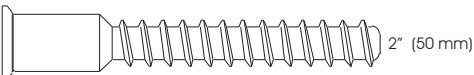
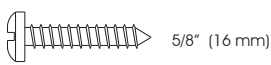
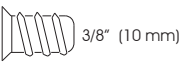
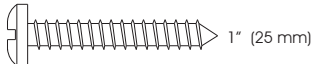
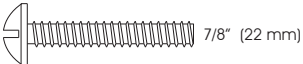
REAL SIZE / GRANDEUR RÉELLE / TAMAÑO REAL

CODE / CÓDIGO / PIEZAS	QTY / QTÉ / CANT.	CODE / CÓDIGO / PIEZAS	QTY / QTÉ / CANT.
VC-204	 2" (50 mm) 4	VR-210	 5/8" (16 mm) 8
VE-244	 3/8" (10 mm) 12	VR-212	 1" (25 mm) 24
VF-232	 7/8" (22 mm) 4		
VM-601	 3/4" (20 mm) 4		
VR-207	 1/2" (13 mm) 12		

IMPORTANT NOTICE / NOTE IMPORTANTE / NOTA IMPORTANTE

Group together all the hardware required for each step as the construction of your piece of furniture is progressing.
 Regroupez toutes les quincailleries requises pour chaque étape de façon à vous assurer de tout installer au bon moment.
 Reúna todas las quincallas necesarias para cada una de las etapas de montaje, para asegurar una correcta instalación en el momento adecuado.

▶ IMPORTANT NOTICE / NOTE IMPORTANTE / NOTA IMPORTANTE

Duly complete the self-adhesive sticker. / Assurez-vous de bien remplir l'auto-collant. / Asegúrese de completar correctamente la etiqueta.

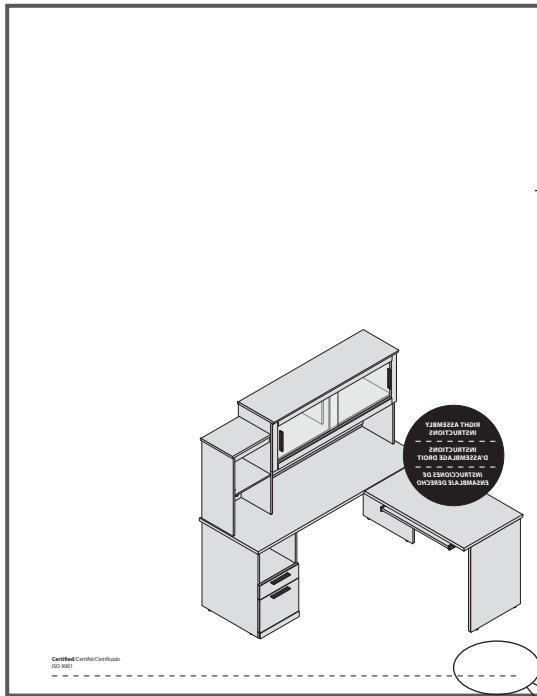

**PRODUCTION
PRODUCCIÓN**

To better serve you!
Pour mieux vous servir!
¡Para servirle mejor!

Model / Modèle / Modelo: _____

Production Number
Numéro de production
Número de producción: _____

Customer Service
Service à la clientèle
Servicio al cliente

Important/Importante

Please retain the self-adhesive sticker which you will find at step 25 of the instruction manual.
Conservez l'autocollant qui sera collé seulement à l'étape 25 du feuillet d'instructions.
Conserve la etiqueta que será pegada sólo en la etapa 25 de la hoja de instrucciones.

▶ IMPORTANT NOTICE / NOTE IMPORTANTE / NOTA IMPORTANTE

▶ Main hardware system / Système de quincaillerie principal / Sistema principal de quincalla

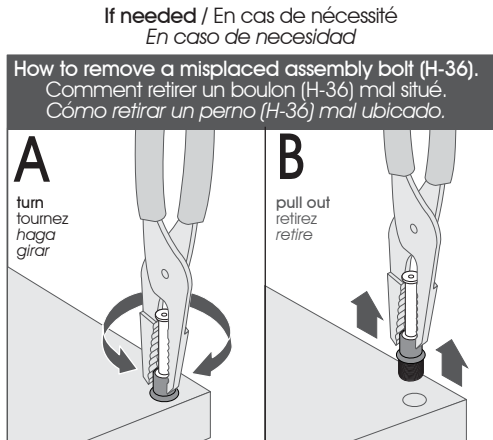
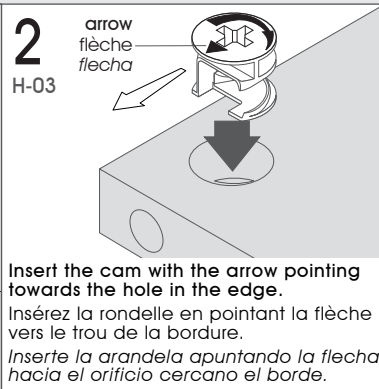
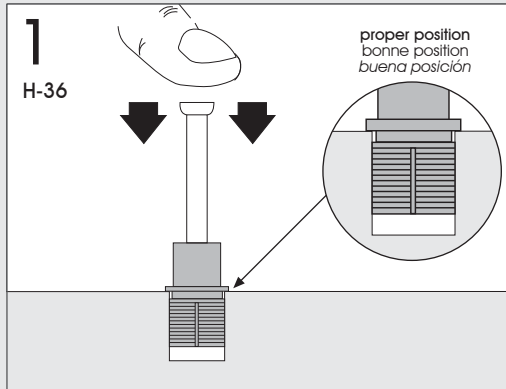

Desk / Bureau / Escritorio

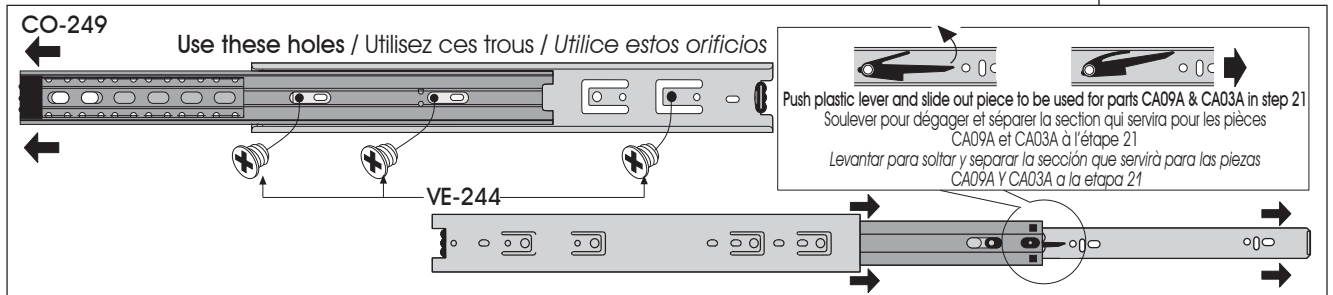
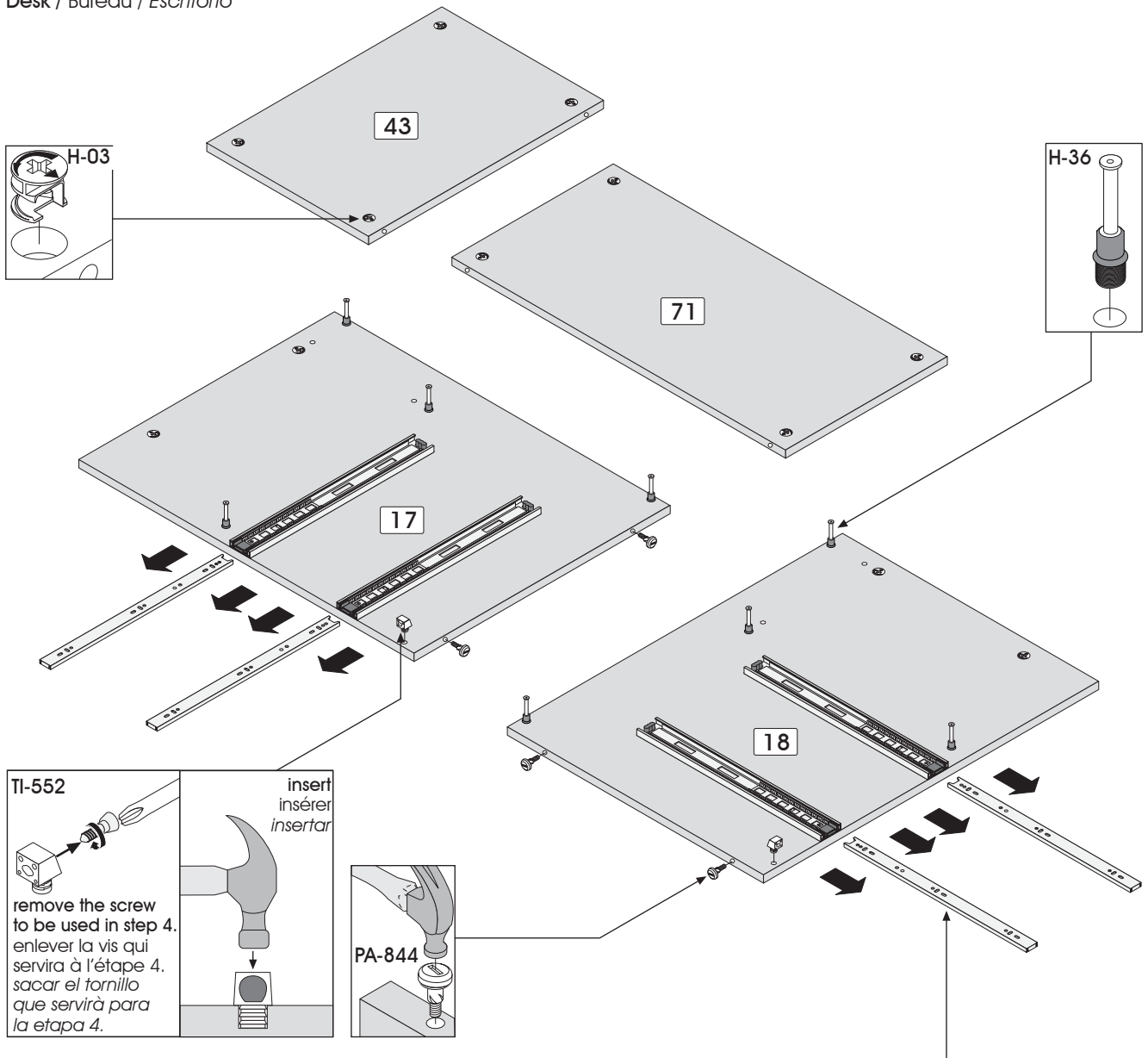

1						
Code / Código / Piezas	CO-249	H-03	H-36	TI-552	PA-844	VE-244
Qty / Qté / Cant. de Piezas	2	12	8	2	4	12

IMPORTANT NOTICE / NOTE IMPORTANTE / NOTA IMPORTANTE

▶ Main hardware system / Système de quincaillerie principal / Sistema principal de quincalla

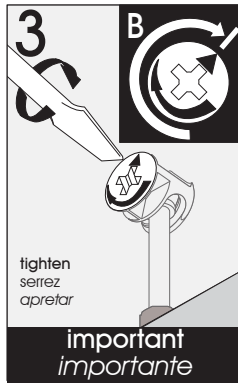
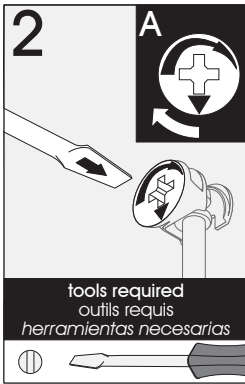
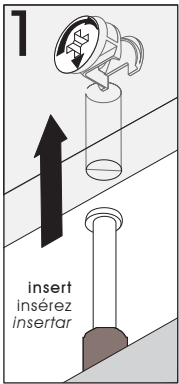

Make sure to properly tighten each cam to ensure furniture solidity. Otherwise, parts could be damaged or the user could be injured.

Assurez-vous de bien resserrer chaque rondelle pour assurer la solidité du meuble. Dans le cas contraire, des pièces pourraient être endommagées ou l'utilisateur pourrait se blesser.

Asegúrese de apretar bien cada arandela para garantizar la solidez del mueble. De lo contrario, podría provocarse daño a las piezas o las personas.

2 PRE-ASSEMBLY / PRÉ-ASSEMBLAGE / PREENSAMBLAJE

Desk / Bureau / Escritorio

Assemble on the back edge

Assemblez sur la bordure arrière

Realice el ensamblaje sobre el borde trasero

Assembling sequence

Séquence d'assemblage

Secuencia de ensamblaje

Parts / Pièces / Piezas:

18 71 43 17

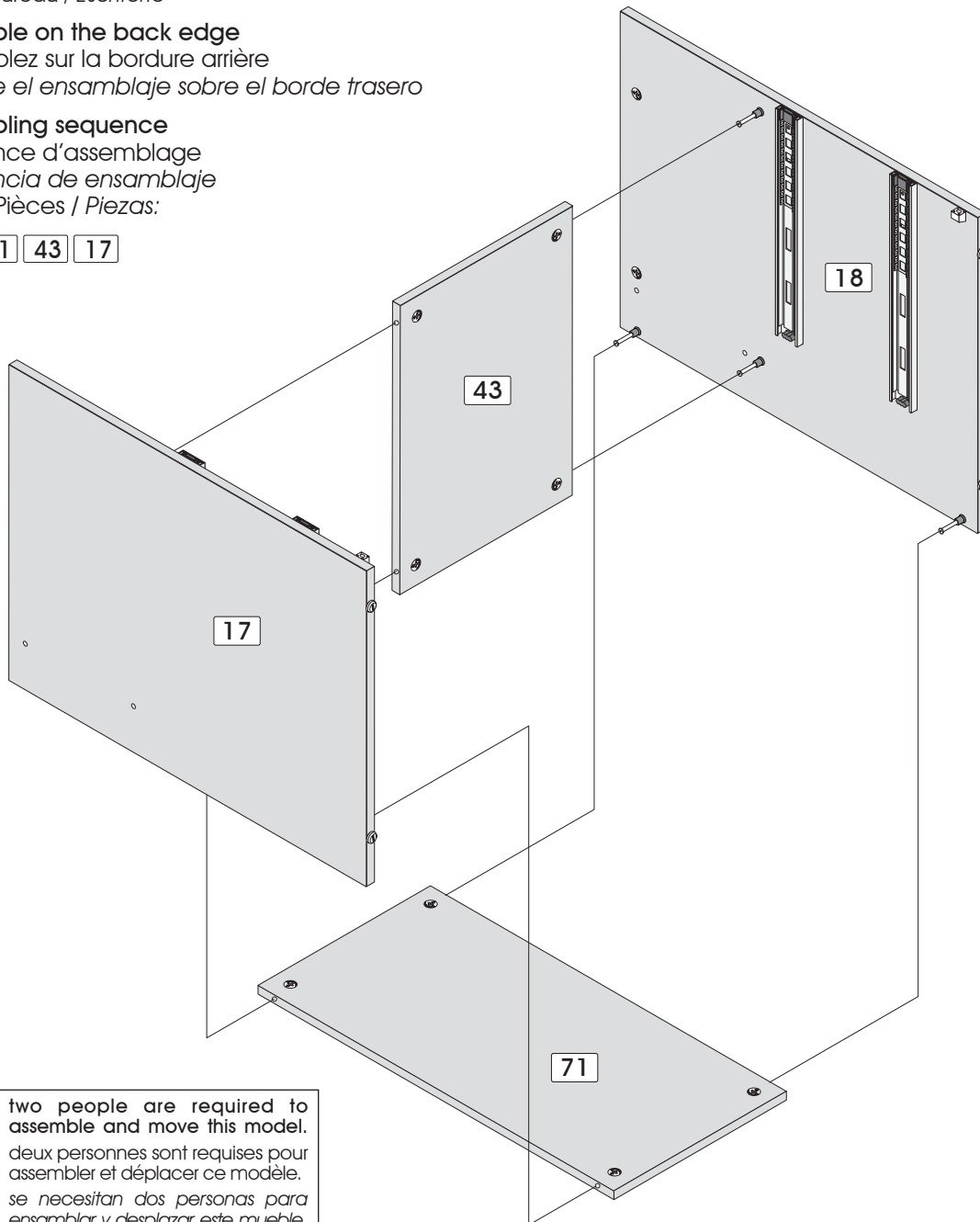

two people are required to assemble and move this model.

deux personnes sont requises pour assembler et déplacer ce modèle.
se necesitan dos personas para ensamblar y desplazar este mueble.

3 HARDWARE INSTALLATION / INSTALLATION DES QUINCAILLERIES / INSTALACIÓN DE LAS QUINCALLAS

Desk / Bureau / Escritorio

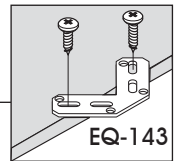
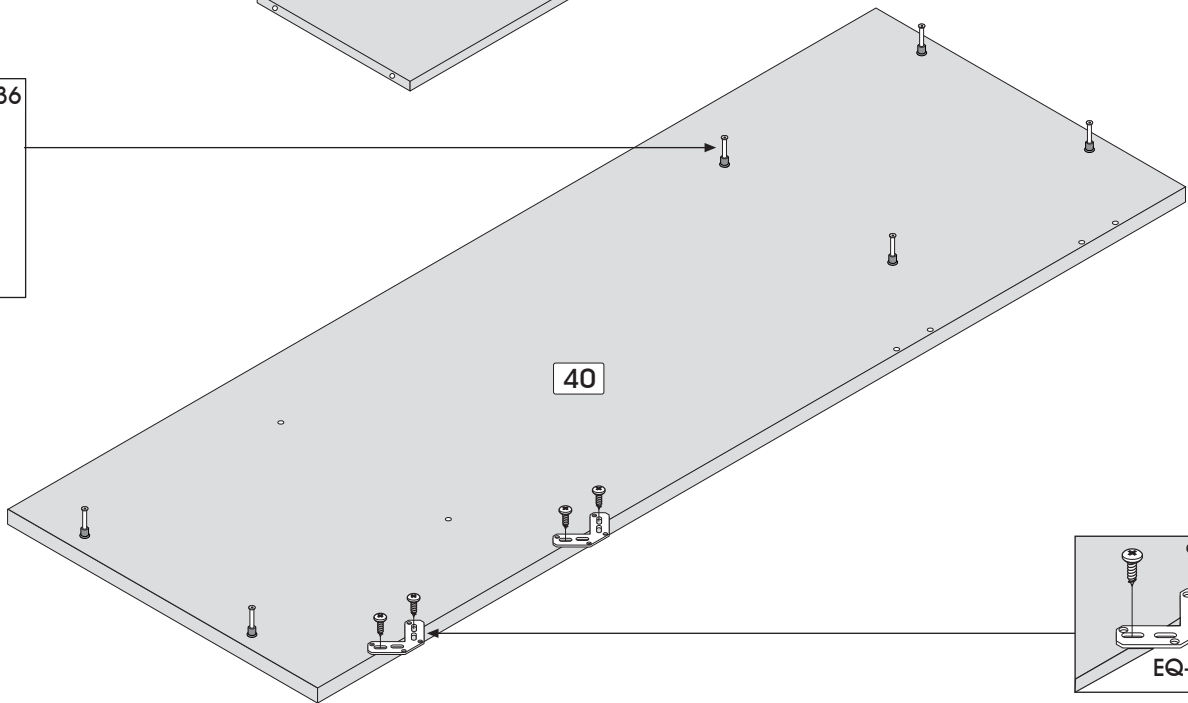
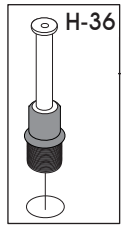
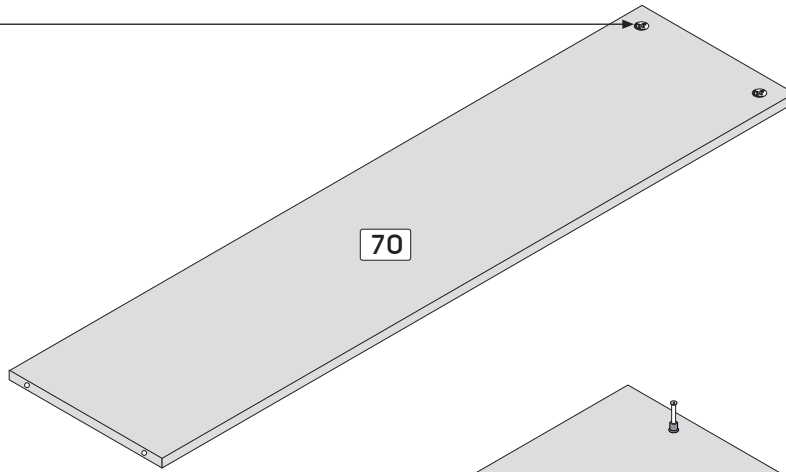
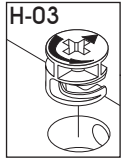
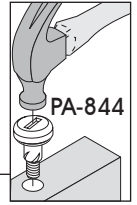
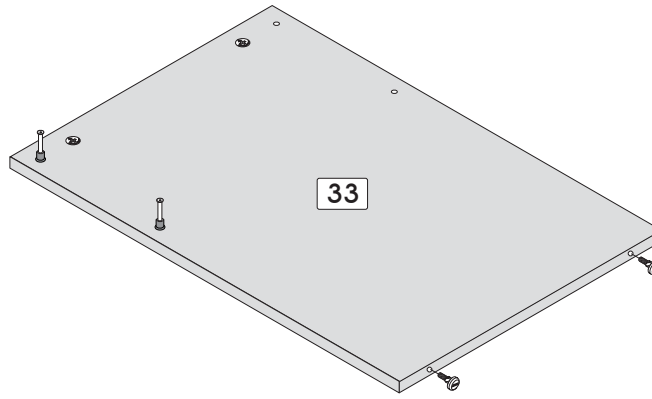

3

Code / Código / Piezas

Qty / Qté / Cant. de Piezas



H-03

4



H-36

8

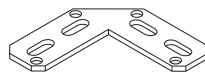

EQ-143

2



PA-844

2



VR-210

4

Desk / Bureau / Escritorio

Assemble upside down

Assemblez en position renversée

Realice el ensamblaje en posición invertida

Assembling sequence

Séquence d'assemblage

Secuencia de ensamblaje

Parts / Pièces / Piezas:

18	17	+	70	33	+	40	85
----	----	---	----	----	---	----	----

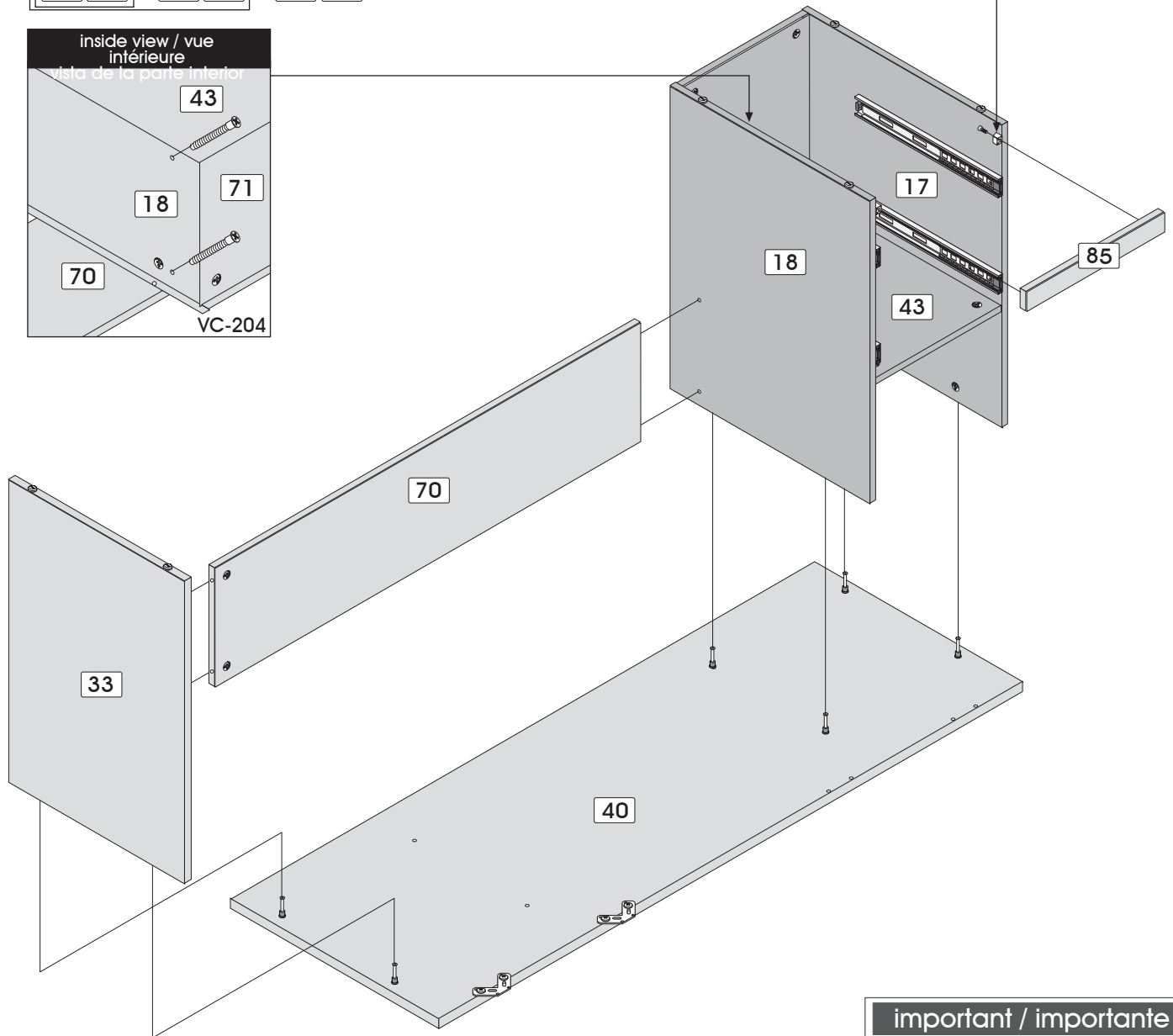
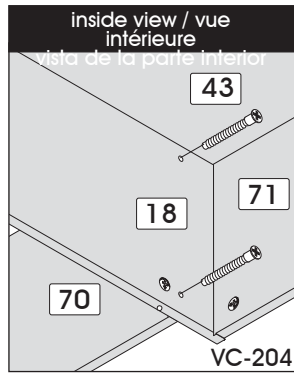

two people are required to assemble and move this model.
deux personnes sont requises pour assembler et déplacer ce modèle.
se necesitan dos personas para ensamblar y desplazar este mueble.

Use the remaining screws from step 1.

Utilisez les vis restantes de l'étape 1.

Utilizar los tornillos restante de la etapa 1.

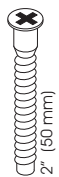

Code / Código / Piezas VC-204

Qty / Qté / Cant. de Piezas 2

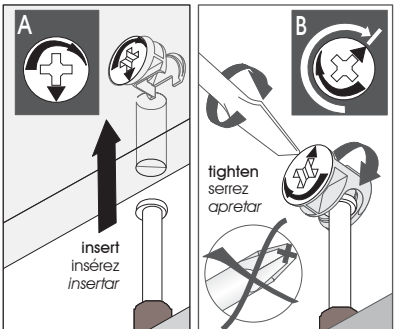
important / importante

5 HARDWARE INSTALLATION / INSTALLATION DES QUINCAILLERIES / INSTALACIÓN DE LAS QUINCALLAS

Desk / Bureau / Escritorio

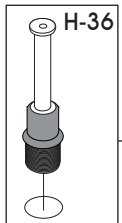
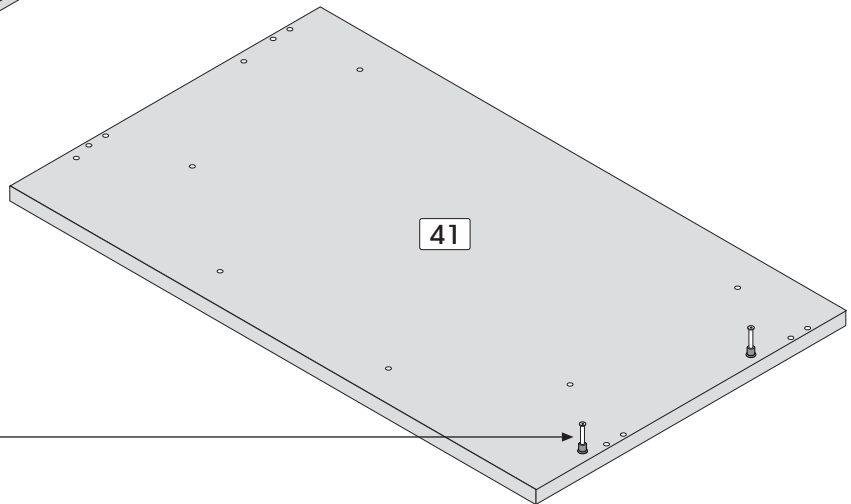
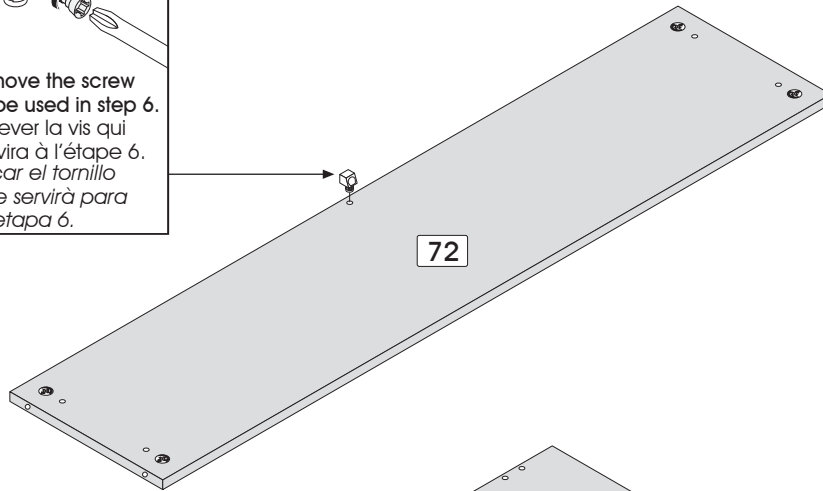
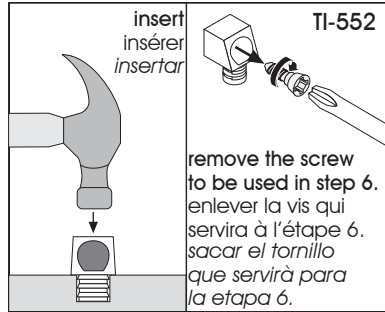
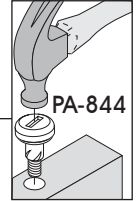
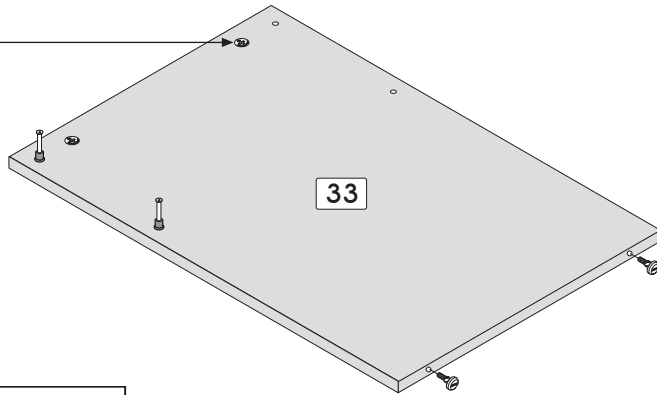
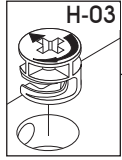

5

Code / Código / Piezas

Qty / Qté / Cant. de Piezas



H-03

6

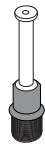

H-36

4



TI-552

1



PA-844

2

1" (25 mm)

Desk / Bureau / Escritorio



two people are required to assemble and move this model.
deux personnes sont requises pour assembler et déplacer ce modèle.
se necesitan dos personas para ensamblar y desplazar este mueble.

Assemble upside down
Assemblez en position renversée
Realice el ensamblaje en posición invertida

Assembling sequence
Séquence d'assemblage
Secuencia de ensamblaje
Parts / Pièces / Piezas:

41 33 72

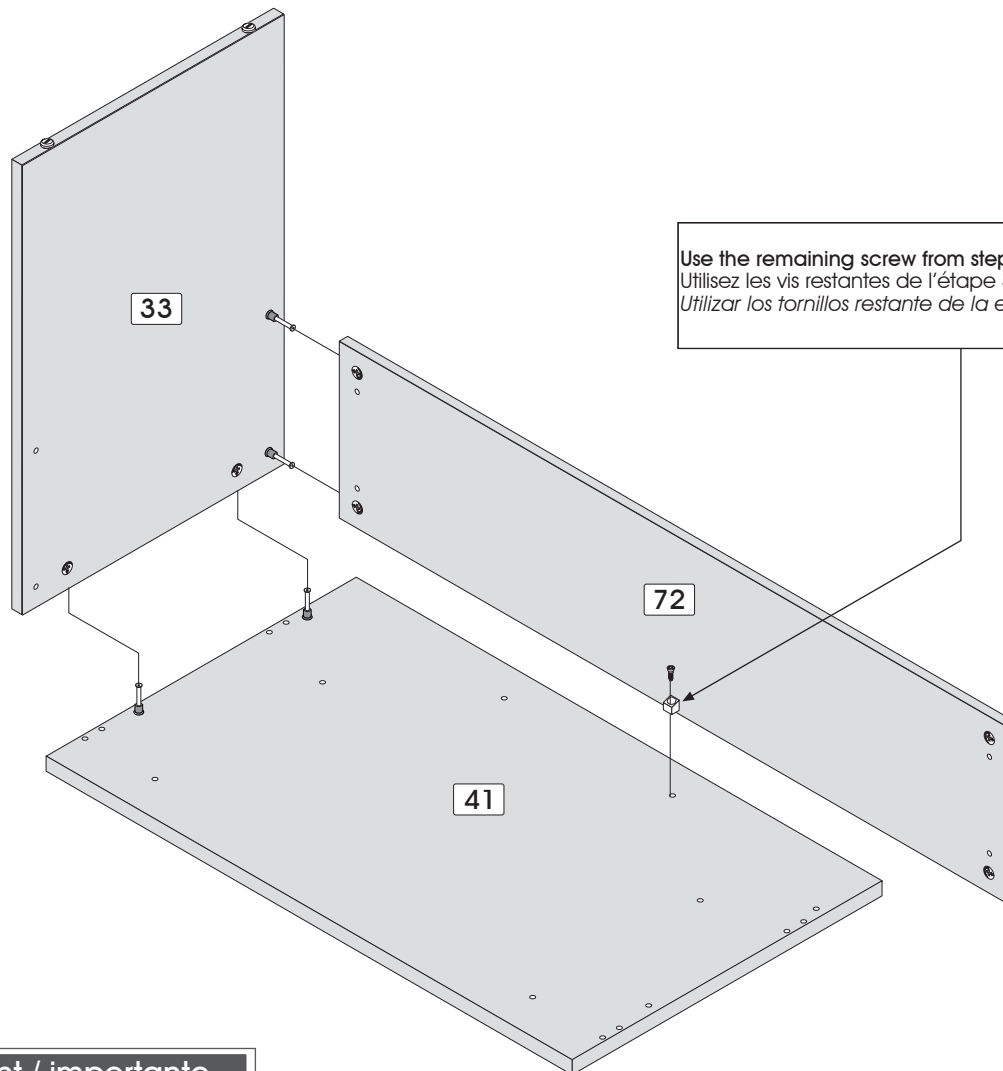

Use the remaining screw from step 5.
Utilisez les vis restantes de l'étape 5.
Utilizar los tornillos restante de la etapa 5.



T1-552

important / importante

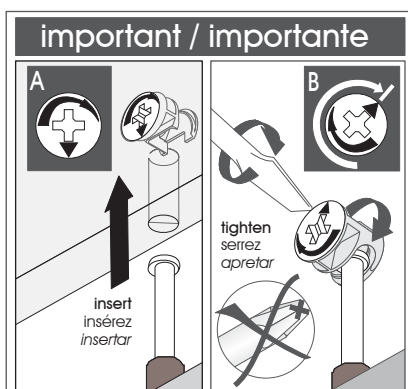

Desk / Bureau / Escritorio

Assembling sequence
 Séquence d'assemblage
 Secuencia de ensamblaje
 Parts / Pièces / Piezas:

40 33 + 41 72

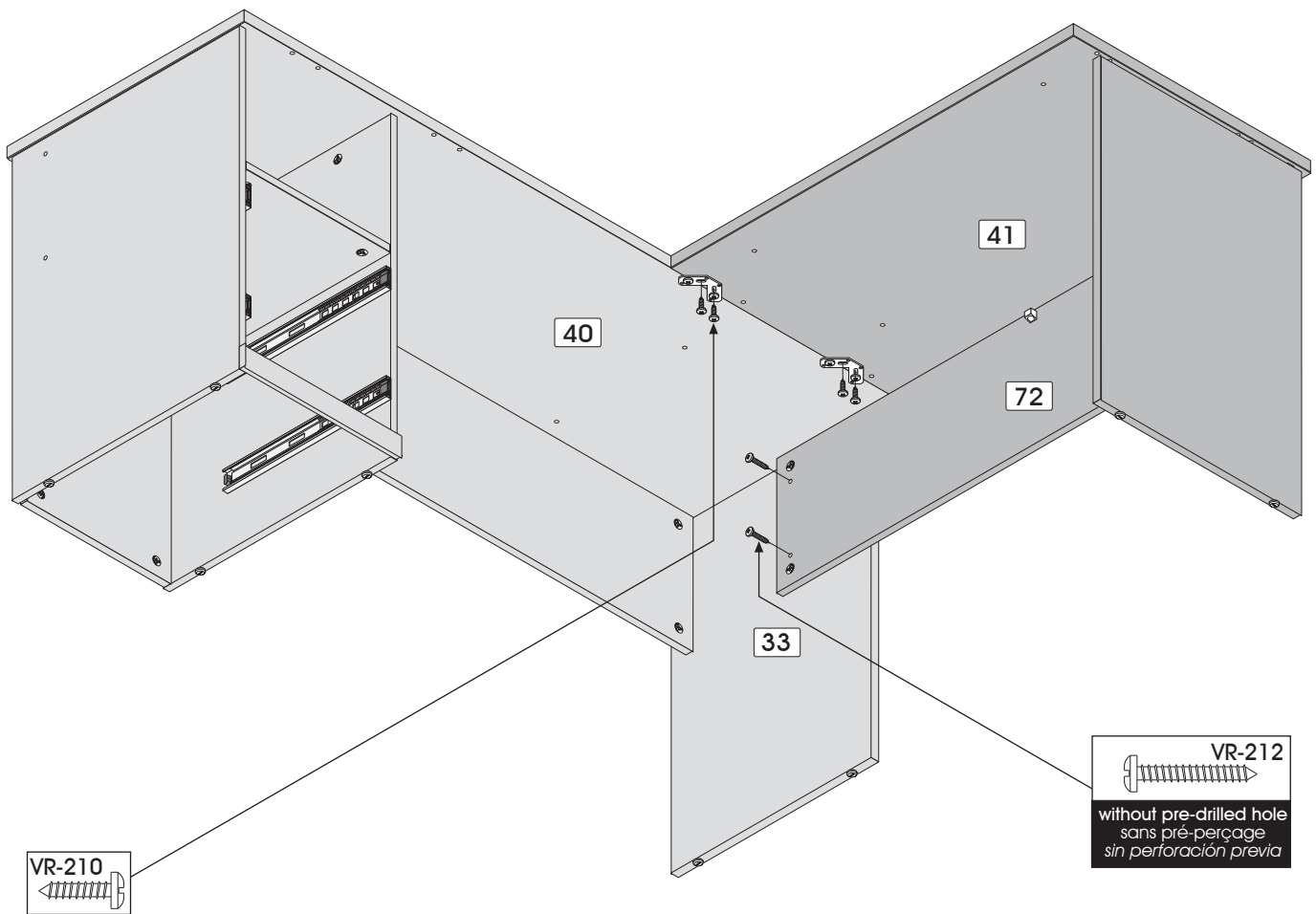

Code / Código / Piezas	VR-210	VR-212
Qty / Qté / Cant. de Piezas	4	2

 two people are required to assemble and move this model.
 deux personnes sont requises pour assembler et déplacer ce modèle.
 se necesitan dos personas para ensamblar y desplazar este mueble.

Hutch / Étagère / Estantería

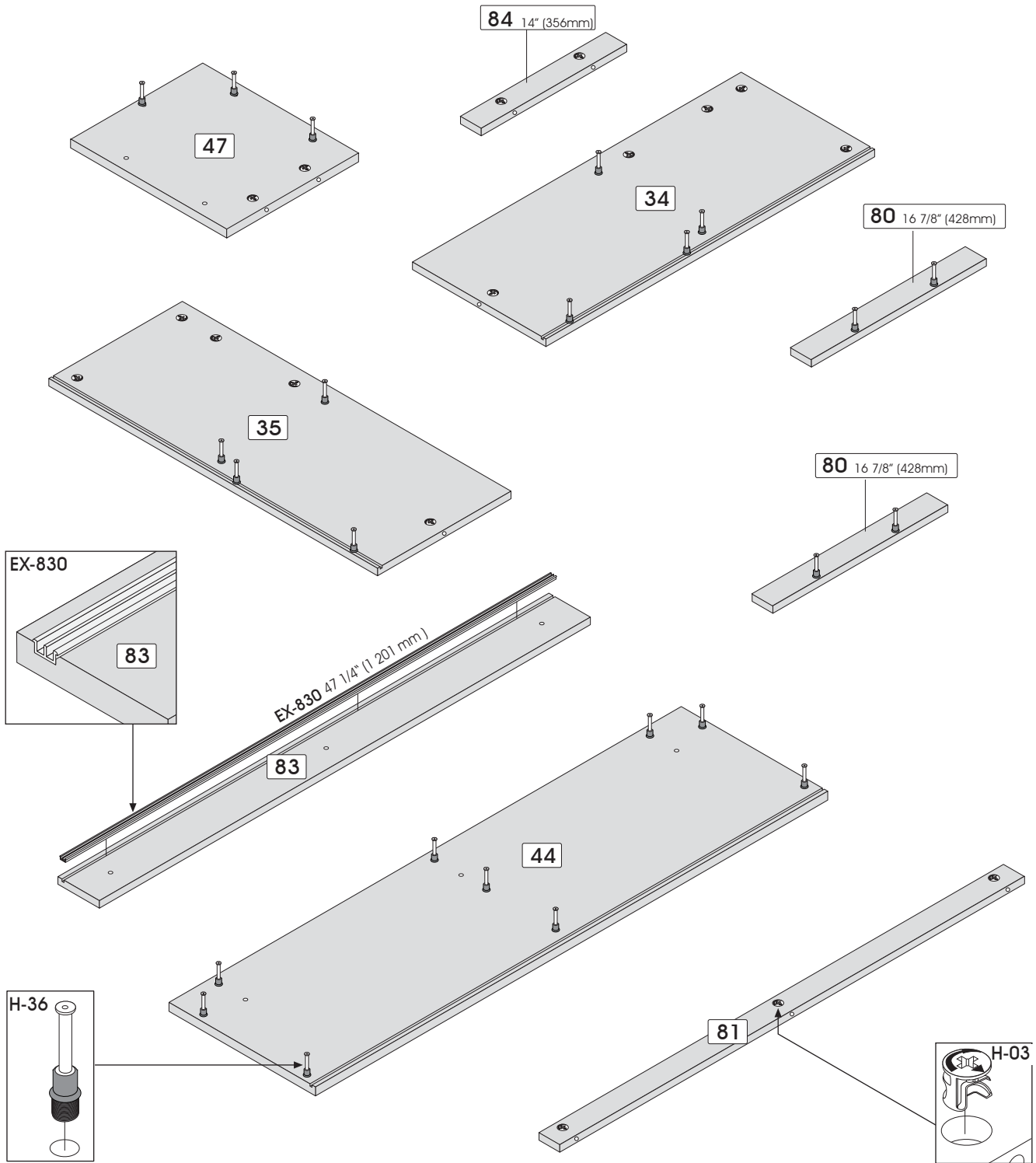

Code / Código / Piezas	H-03	H-36	EX-830
Qty / Qté / Cant. de Piezas	17	24	1

Hutch / Étagère / Estantería

Assembling sequence
 Séquence d'assemblage
 Secuencia de ensamblaje
 Parts / Pièces / Piezas:

47 + 84 14" (356mm)

35 + 80 16 7/8" (428mm)

44 81 83

34 + 80 16 7/8" (428mm)

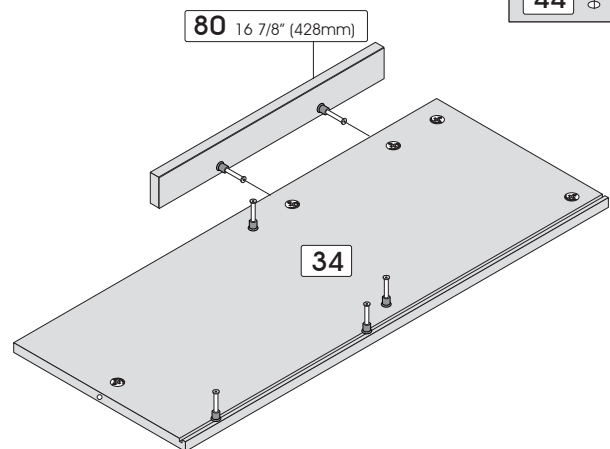
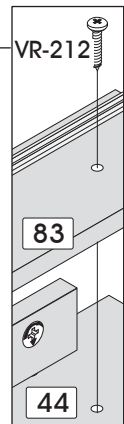
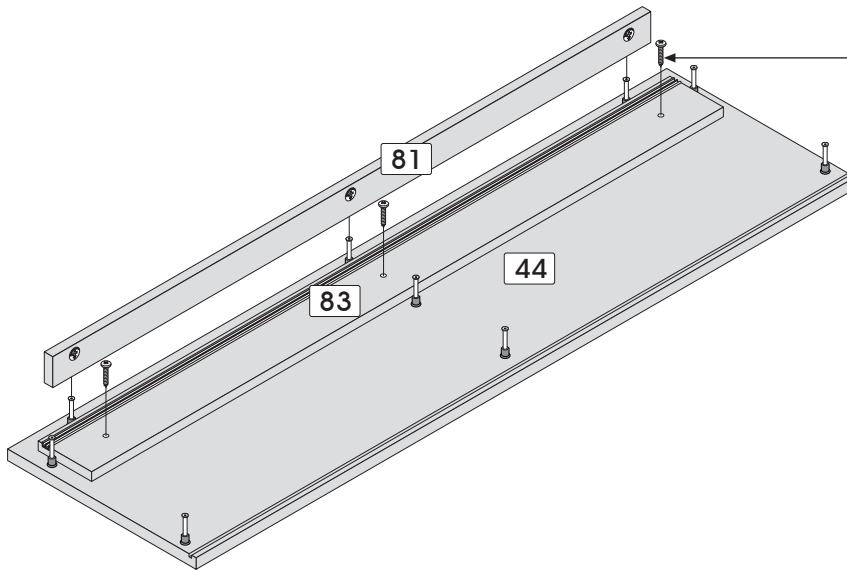
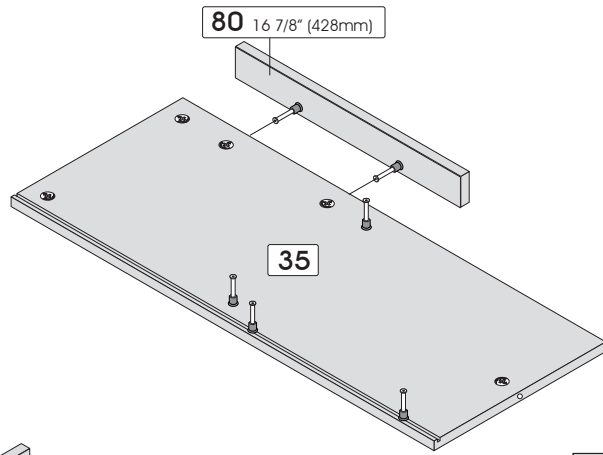
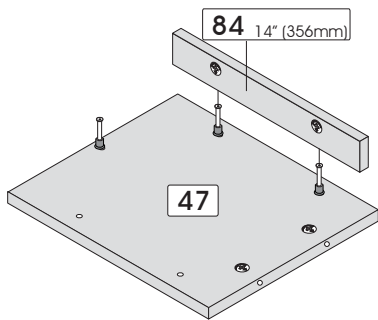
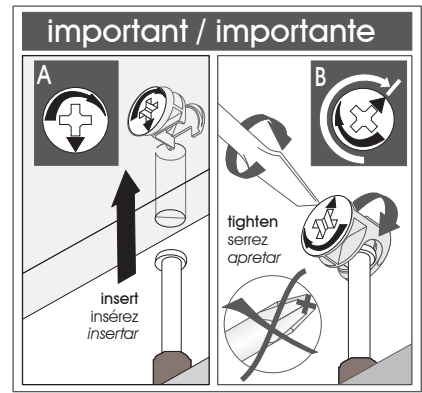

Code / Código / Piezas VR-212
 Qty / Qté / Cant. de Piezas 3

Hutch / Étagère / Estantería

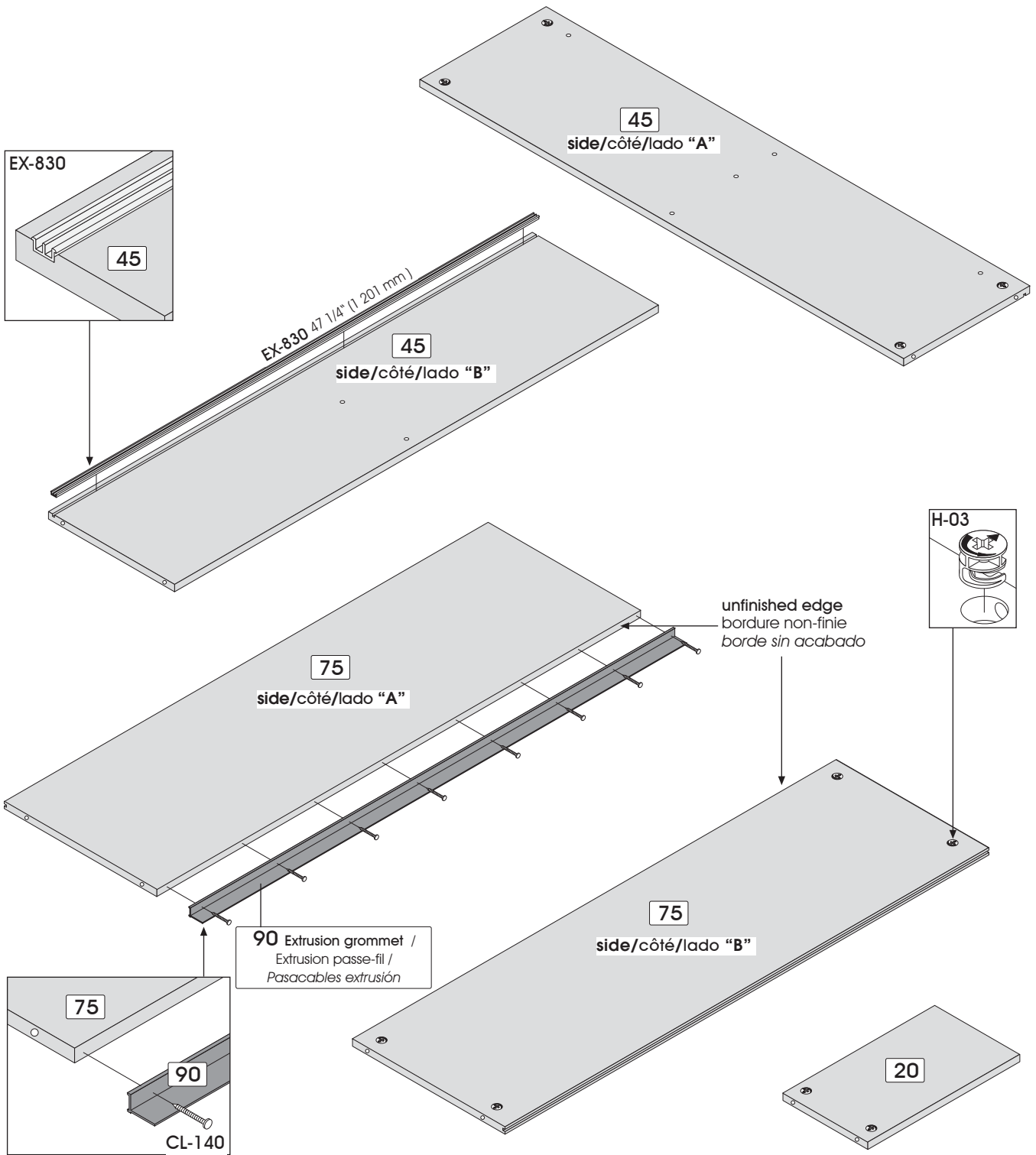

Code / Código / Piezas
Qty / Qté / Cant. de Piezas



H-03
10



EX-830
1



CL-140
8

Hutch / Étagère / Estantería

Assemble on the back edge

Assemblez sur la bordure arrière

Realice el ensamblaje sobre el borde trasero

Assembling sequence

Séquence d'assemblage

Secuencia de ensamblaje

Parts / Pièces / Piezas:

34 75 45 35 20

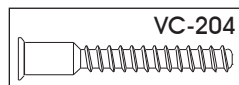
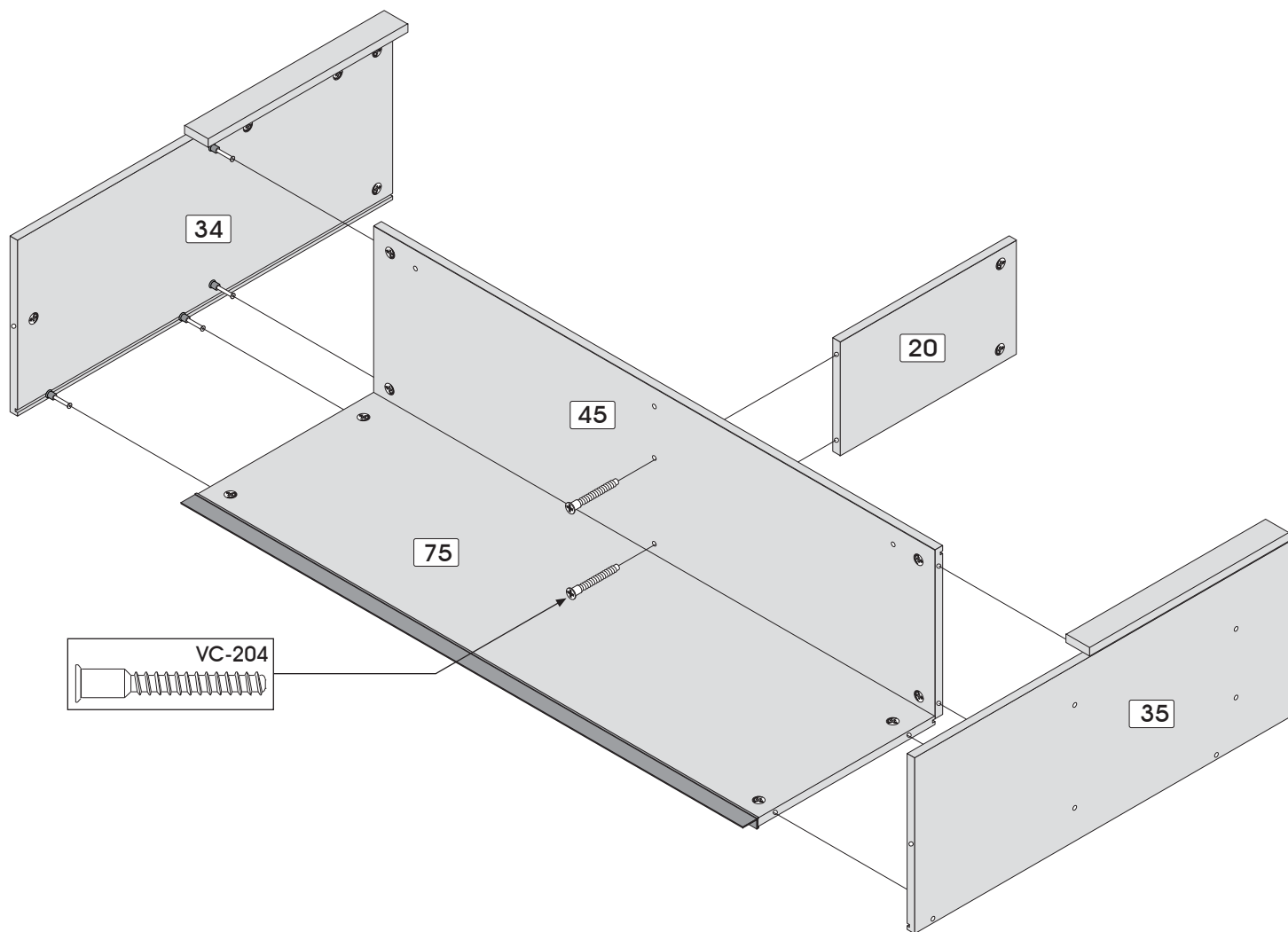
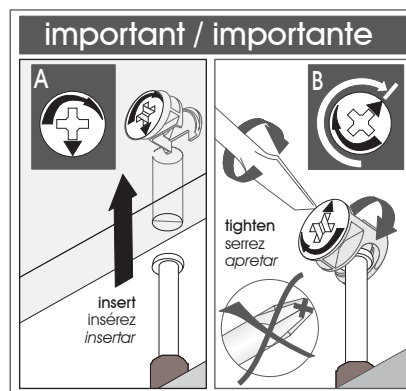

11

VC-204
2" (50 mm)

Code / Código / Piezas VC-204
Qty / Qté / Cant. de Piezas 2

two people are required to assemble and move this model.
deux personnes sont requises pour assembler et déplacer ce modèle.
se necesitan dos personas para ensamblar y desplazar este mueble.

Hutch / Étagère / Estantería

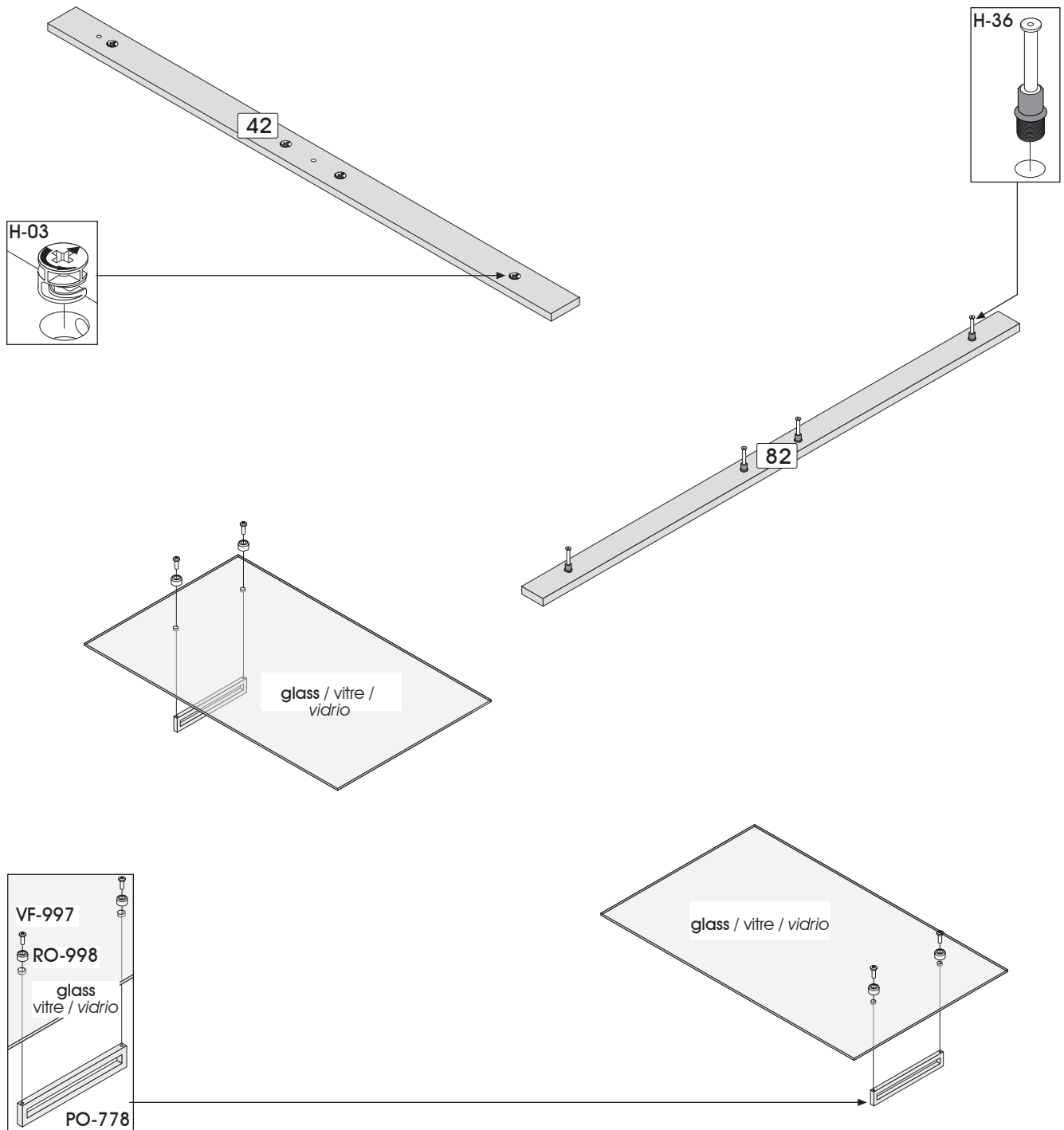

Code / Código / Piezas

Qty / Qté / Cant. de Piezas



H-03

4

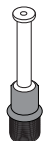

H-36

4

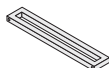

PO-778

2



RO-998

4



VF-997

4

13 PRE-ASSEMBLY / PRÉ-ASSEMBLAGE / PREENSAMBLAJE

Hutch / Étagère / Estantería

Assemble on the back edge

Assemblez sur la bordure arrière

Realice el ensamblaje sobre el borde trasero

Assembling sequence

Séquence d'assemblage

Secuencia de ensamblaje

Parts / Pièces / Piezas:

45 42 82

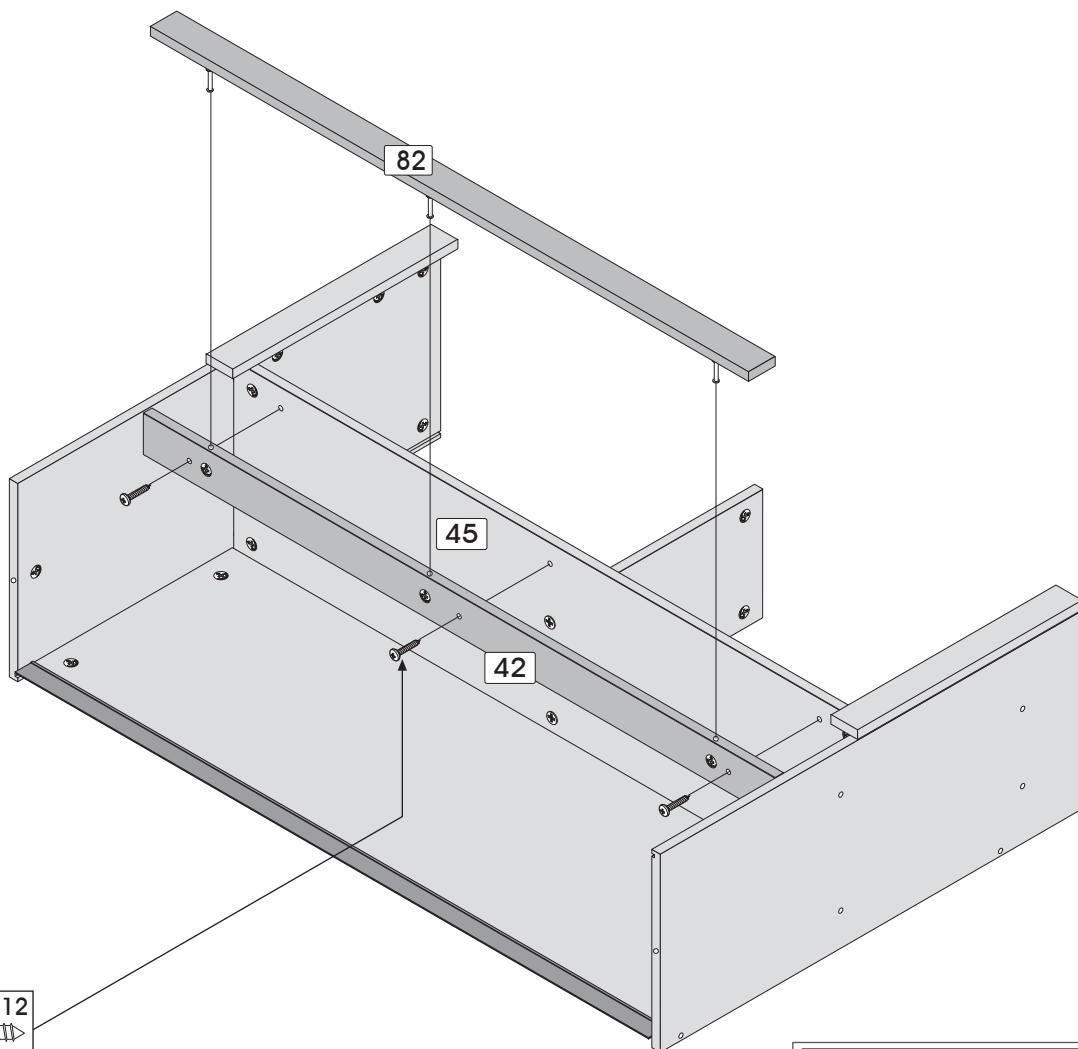

13



Code / Código / Piezas VR-212

Qty / Qté / Cant. de Piezas 3

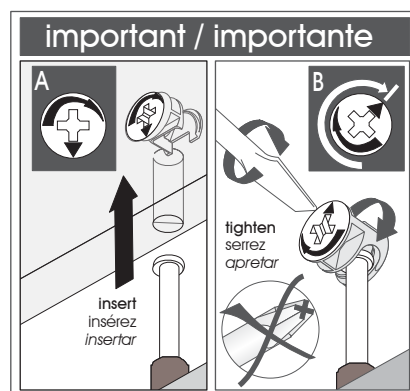

Hutch / Étagère / Estantería

Place the part in an upright position
Placer le meuble en position debout
Coloque el mueble en posición vertical

Assembling sequence
Séquence d'assemblage
Secuencia de ensamblaje
Parts / Pièces / Piezas:

34 20 35 + 74 back panel / dos / panel trasero + 44

Important/Importante

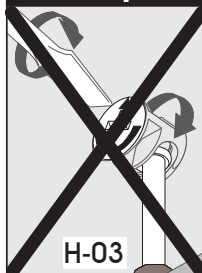

Do not tighten the round piece H-03 that assembles the pieces 34, 20 and 35 through 44.
Ne pas serrer les rondelles (H-03) qui assemblent les pièces 34, 20 et 35 à la 44.
No apriete la pieza redonda H-03 que ensambla las piezas 34, 20 y 35 hasta 44.

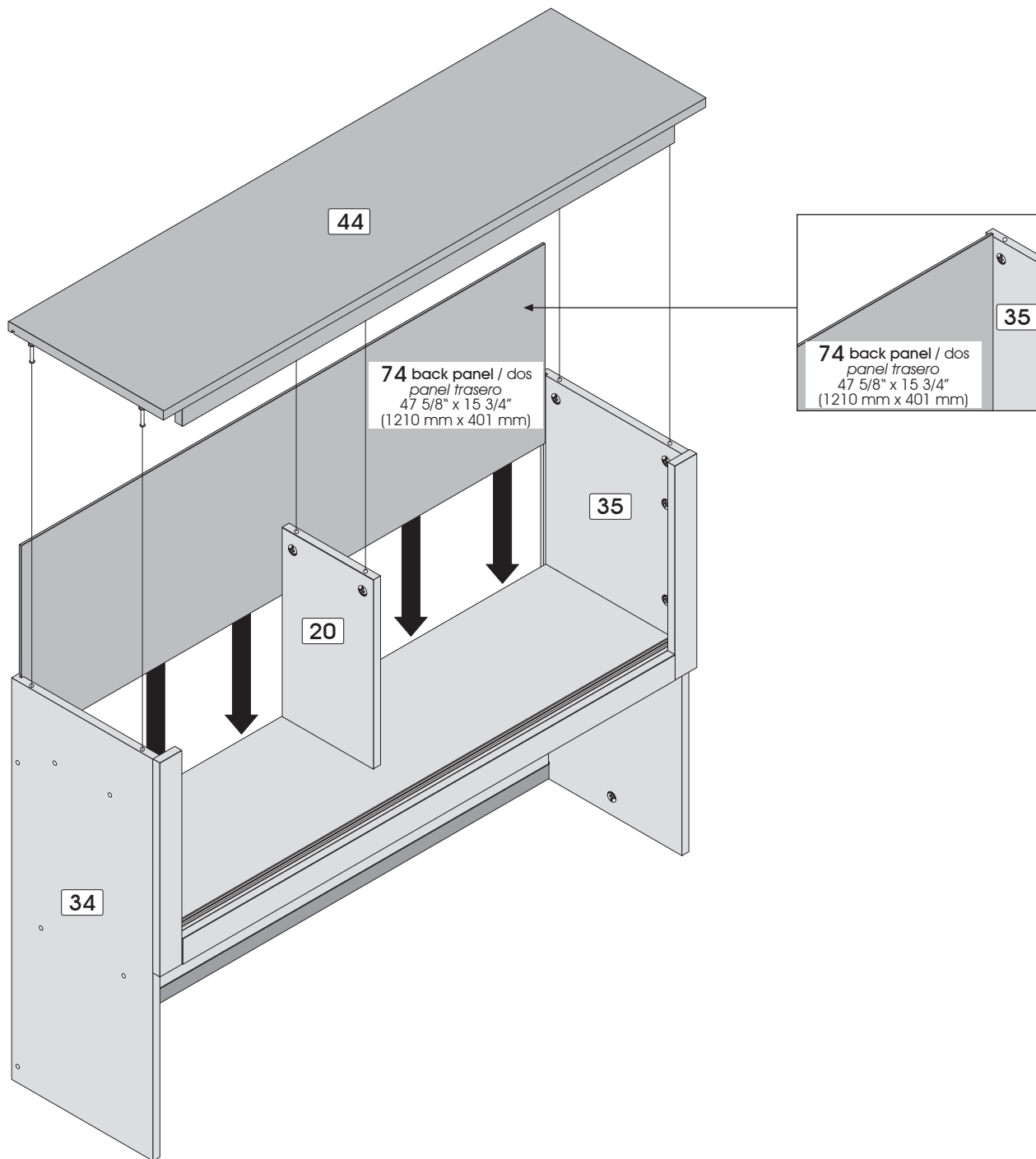

Doors / Portes / Puertas

- A** Lift gently the right side of piece 44.
Soulever légèrement le côté droit de la pièce 44.
Levante ligeramente el lado derecho de la pieza 44.
- B** Insert delicately the first door.
Insérer délicatement la première porte.
Inserte delicadamente la primera puerta.
- C** Insert delicately the second door.
Insérer délicatement la deuxième porte.
Inserte delicadamente la segunda puerta.
- D** Lower the piece 44 so that it will be in its original position.
Rabaisser la pièce 44 pour qu'elle soit à sa position de départ.
Baje la pieza 44 para que esté a su posición original.

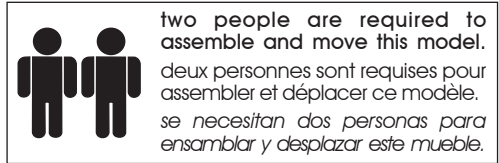

E **Important/Importante**



Remember to tighten the H-03 located on pieces 34, 20 and 35.
N'oubliez pas de serrer les H-03 qui sont situées sur les pièces 34, 20 et 35.
No se olvide de apretar las H-03 que se encuentran en el pieza 34, 20 y 35

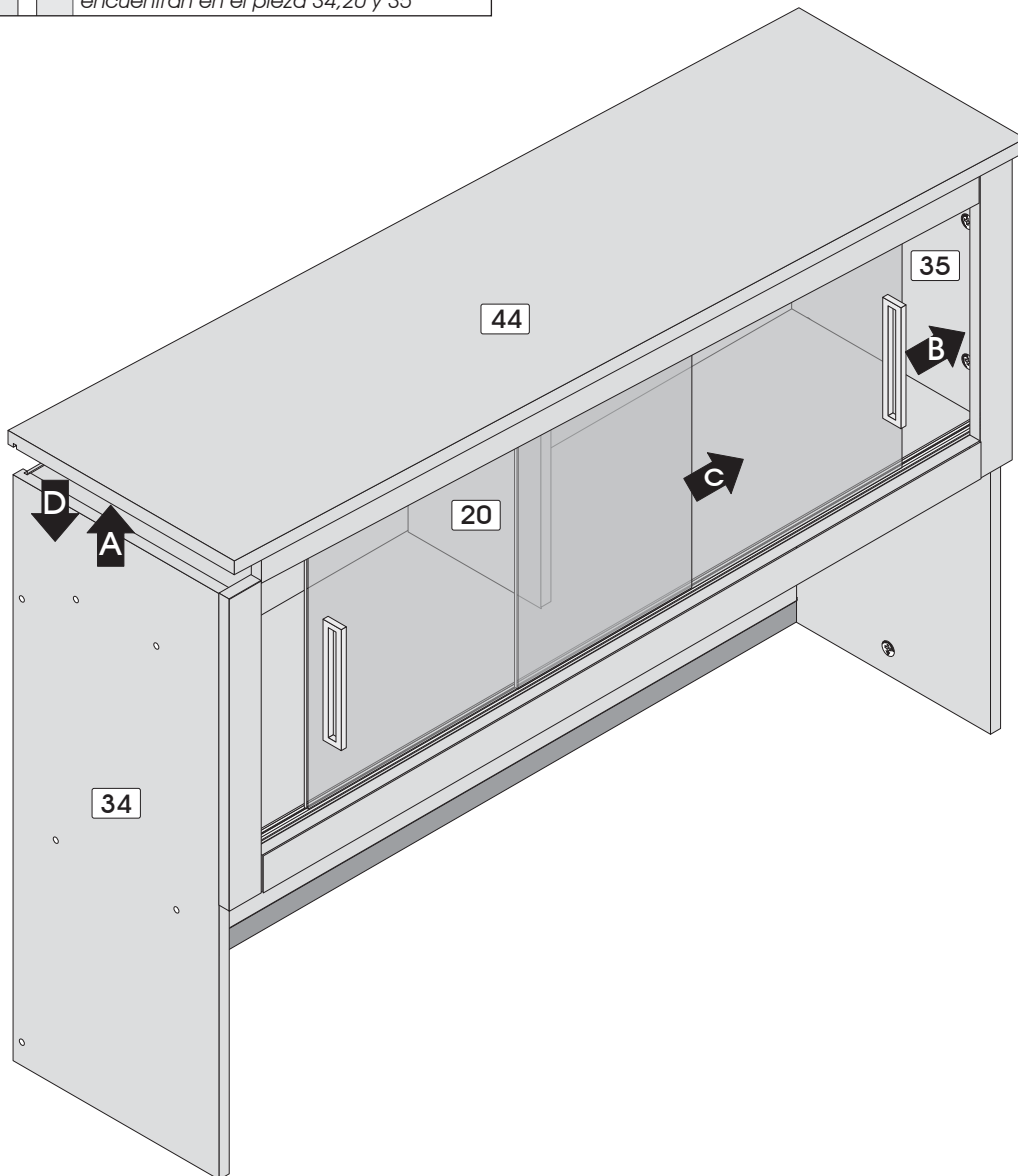

Desk / Bureau / Escritorio

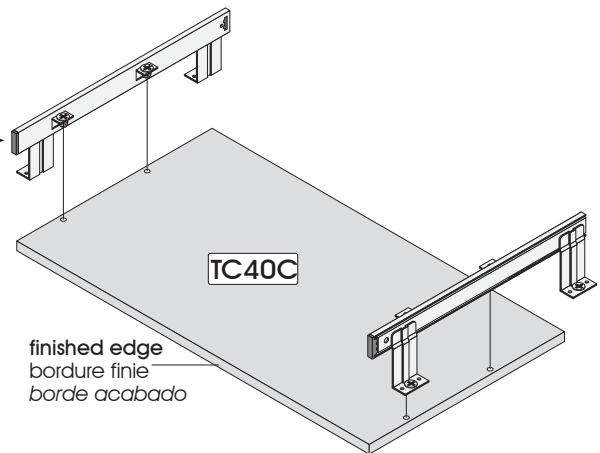
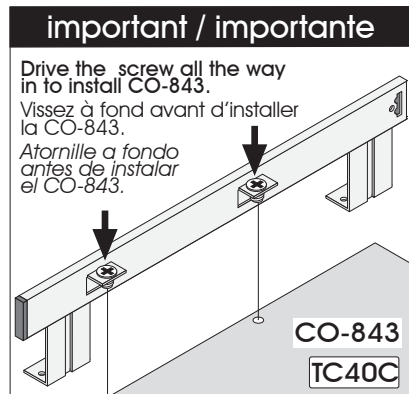
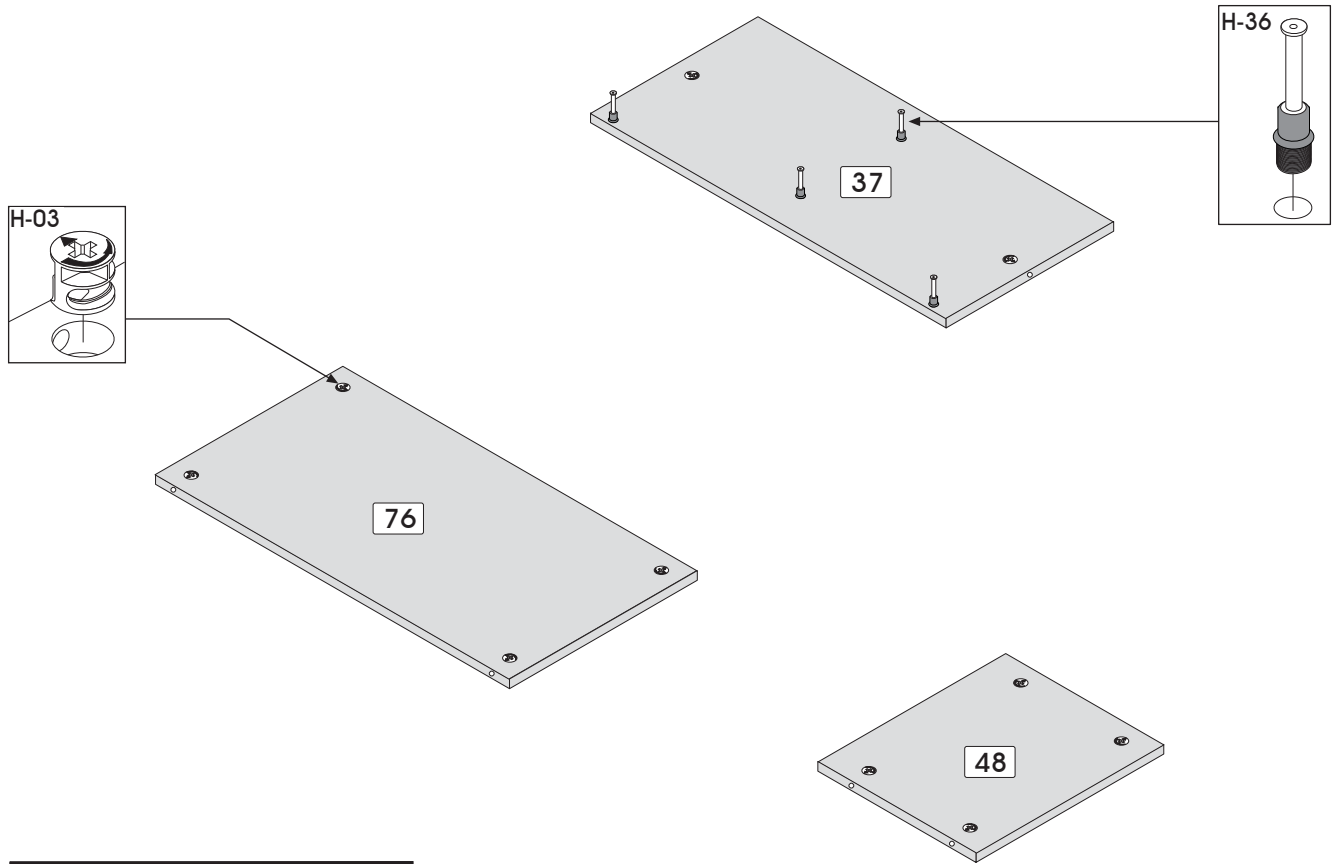

Code / Código / Piezas

Qty / Qté / Cant. de Piezas



H-03

10

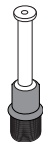

H-36

4

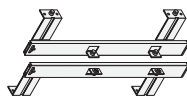

CO-843

1

17 INSTALLATION / INSTALLATION / INSTALACIÓN

Keyboard Shelf / Tablette à clavier / Estante para teclado



two people are required to assemble and move this model.
deux personnes sont requises pour assembler et déplacer ce modèle.
se necesitan dos personas para ensamblar y desplazar este mueble.

important / importante

Drive the screw all the way in to install TC40C
Vissez à fond avant d'installer la TC40C.
Atornille a fondo antes de instalar el TC40C.

41

TC40C

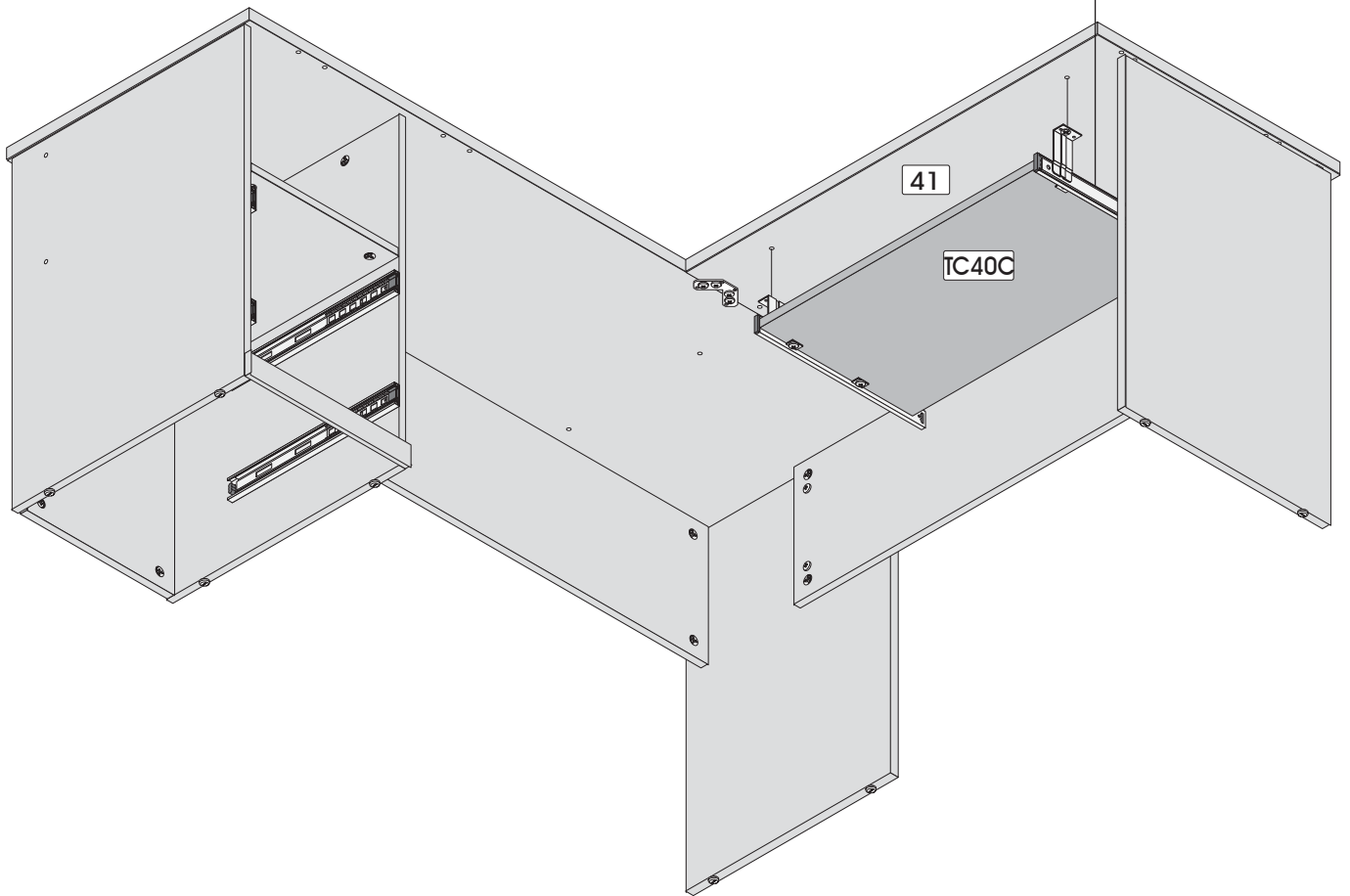

Hutch / Étagère / Estantería

Assemble on the back edge

Assemblez sur la bordure arrière

Realice el ensamblaje sobre el borde trasero

Assembling sequence

Séquence d'assemblage

Secuencia de ensamblaje

Parts / Pièces / Piezas:

37 76 47 48

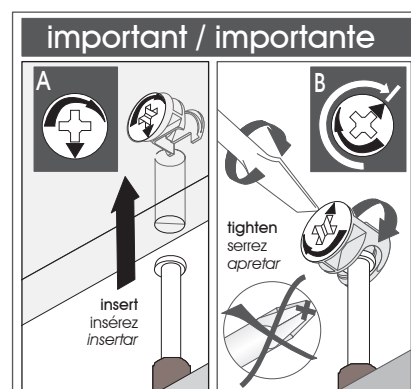
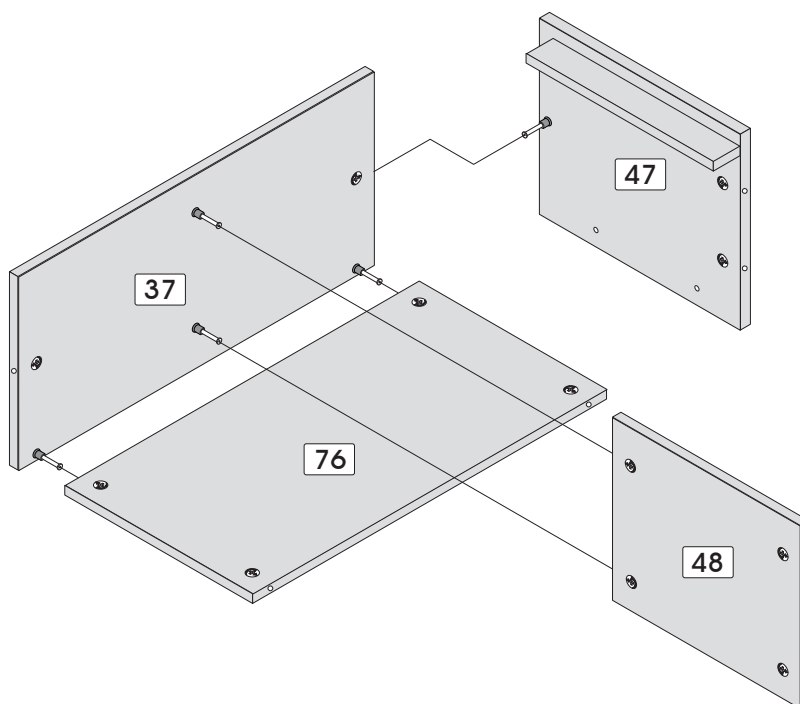

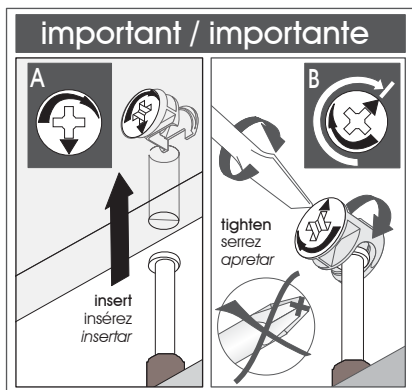

Assembling sequence
Séquence d'assemblage
Secuencia de ensamblaje
Parts / Pièces / Piezas:

34 + 47 48 37

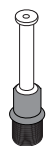
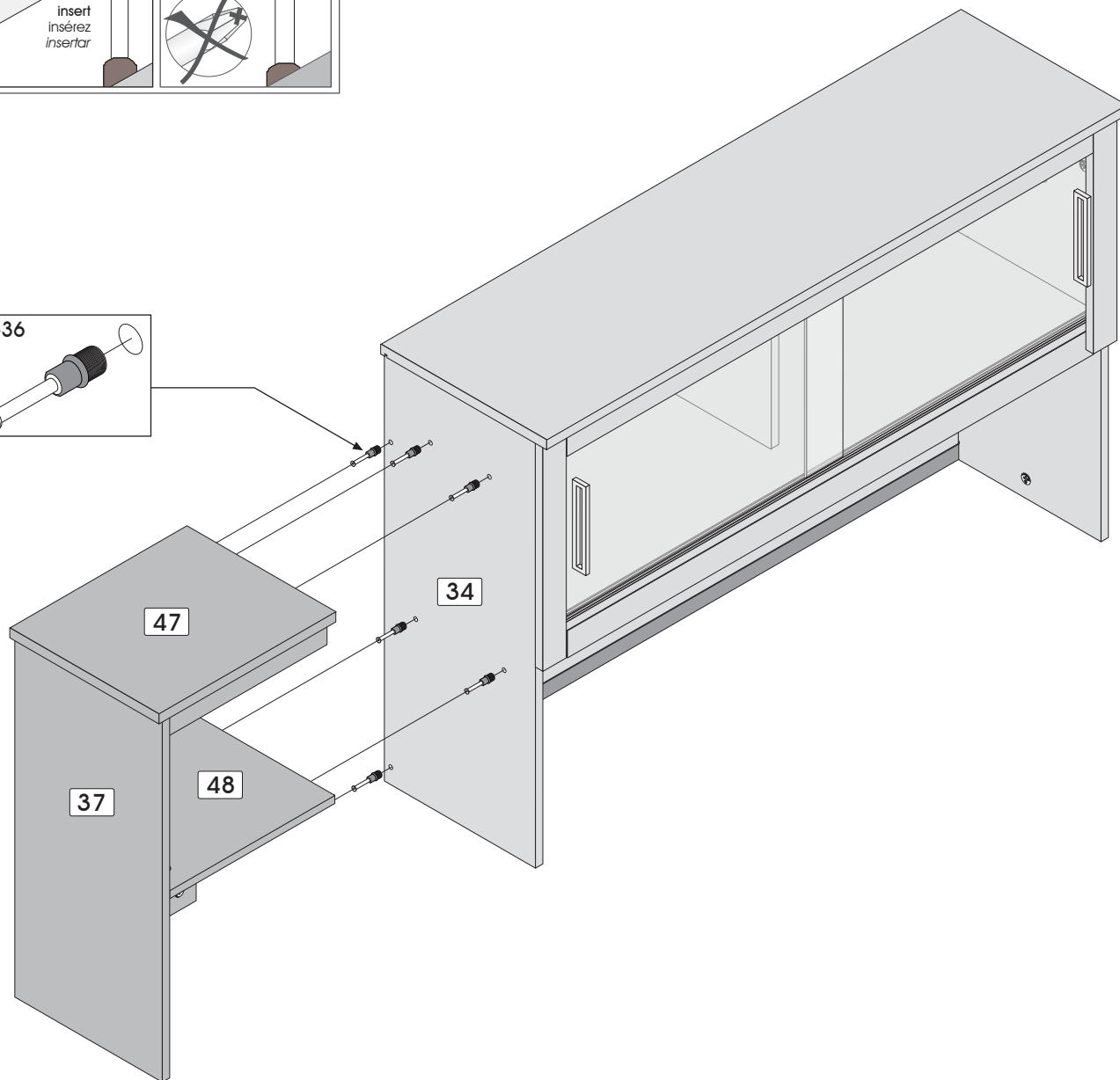
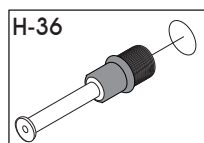

Code / Código / Piezas
Qty / Qté / Cant. de Piezas

H-36
6





two people are required to
assemble and move this model.
deux personnes sont requises pour
assembler et déplacer ce modèle.
se necesitan dos personas para
ensamblar y desplazar este mueble.

Hutch / Étagère / Estantería

Assembling sequence
 Séquence d'assemblage
 Secuencia de ensamblaje
 Parts / Pièces / Piezas:

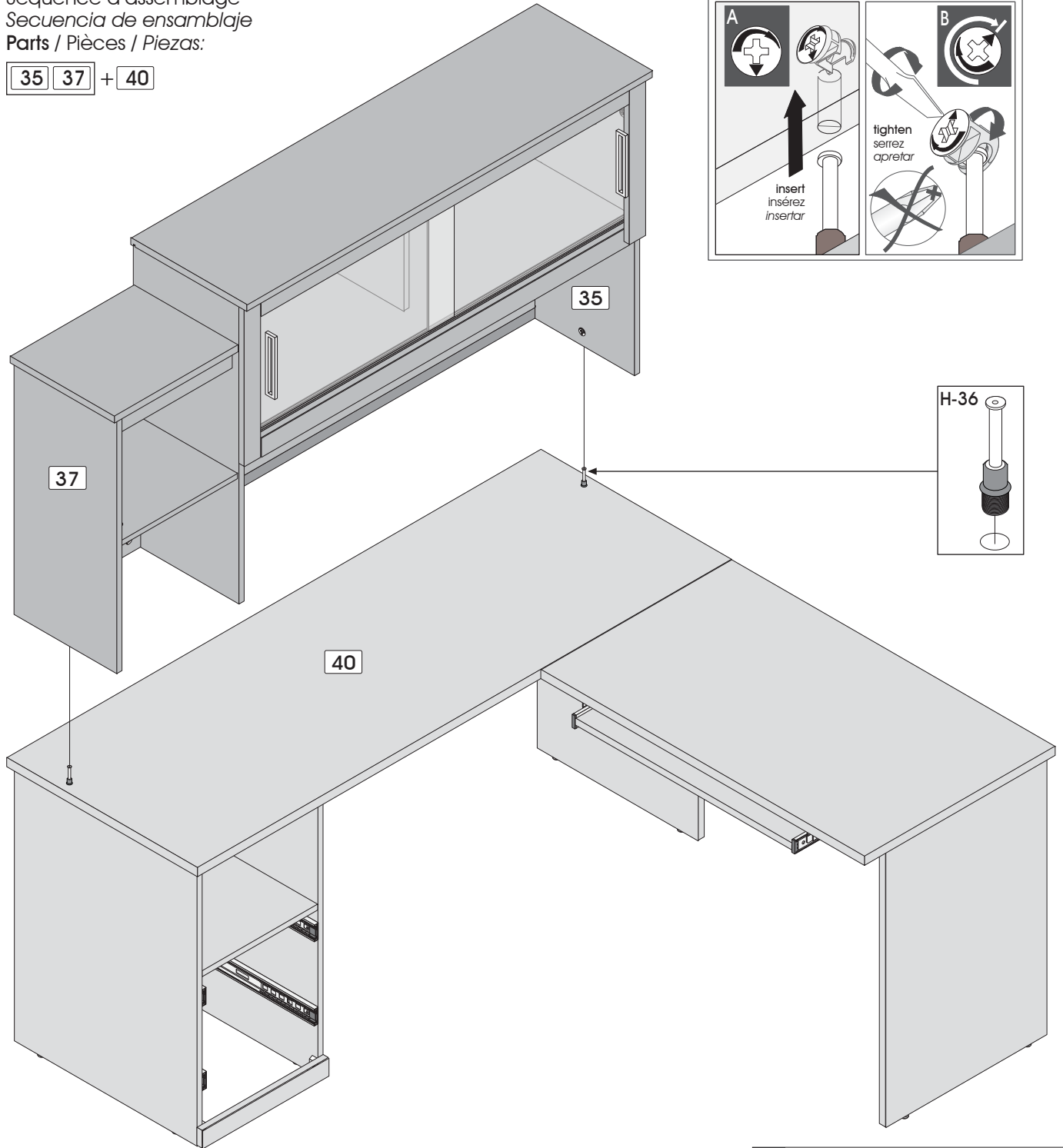
35 37 + 40



 two people are required to assemble and move this model.
 deux personnes sont requises pour assembler et déplacer ce modèle.
 se necesitan dos personas para ensamblar y desplazar este mueble.

20

Code / Código / Piezas
 Qty / Qté / Cant. de Piezas

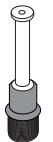

H-36

2

Drawers / Tiroirs / Cajones

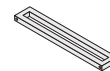
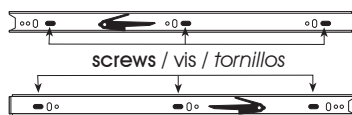
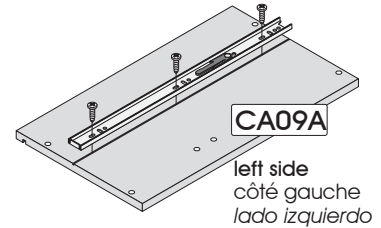
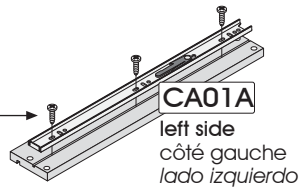
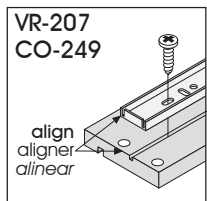
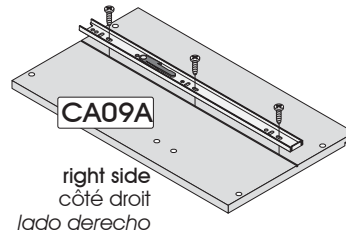
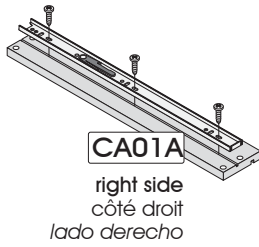
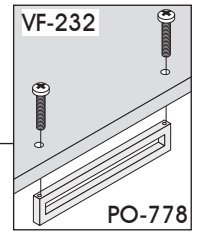
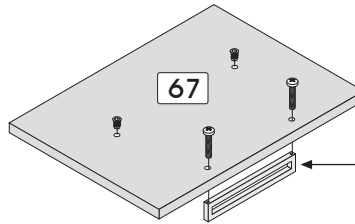
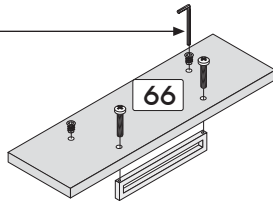
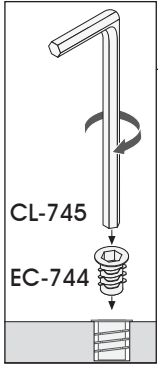



Code / Código / Piezas	CO-249	EC-744	CL-745	PO-778	VR-207	VF-232
Qty / Qté / Cant. de Piezas	2	4	1	2	12	4

Assembling sequence
 Séquence d'assemblage
 Secuencia de ensamblaje
 Parts / Pièces / Piezas:

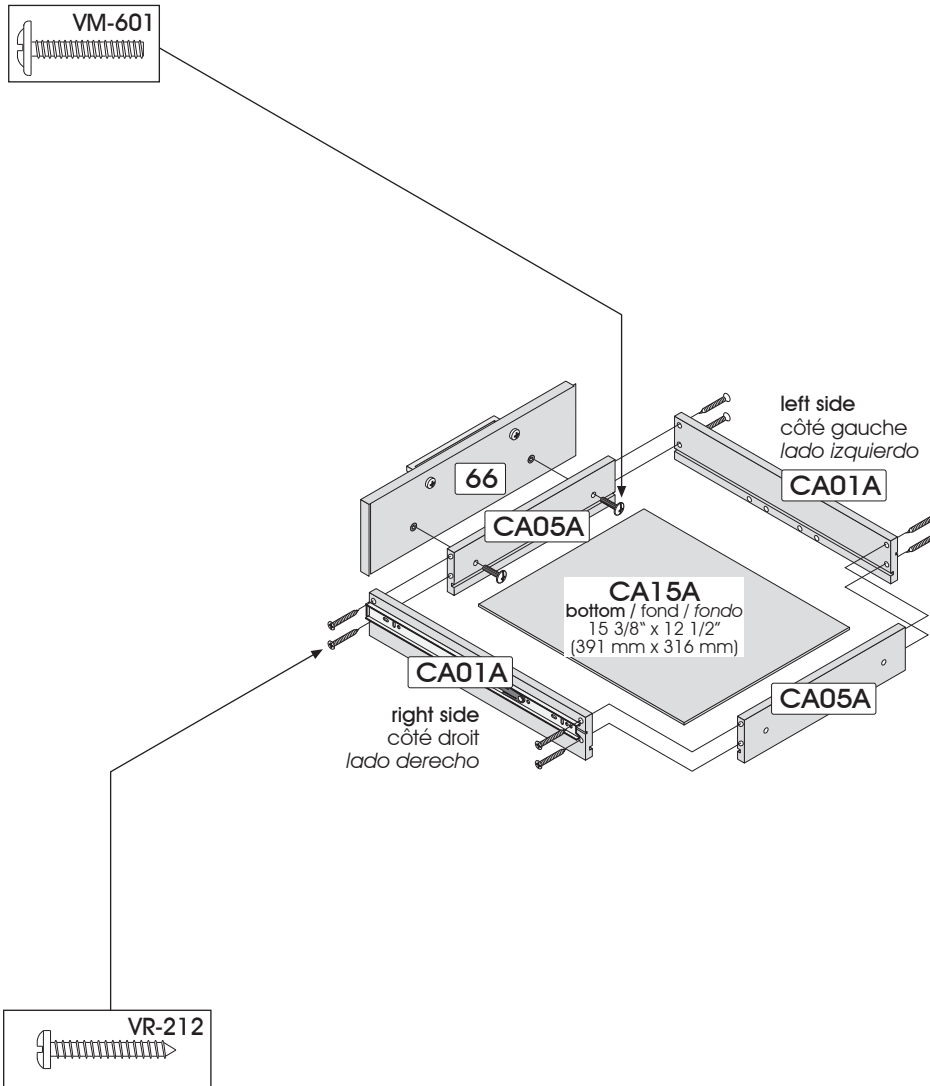
CA05A CA01A CA01A + bottom / fond / fondo + CA05A 66



		
	3/4" (20 mm)	1" (25 mm)
Code / Código / Piezas	VM-601	VR-212
Qty / Qté / Cant. de Piezas	2	8

Drawer / Tiroir / Cajón

Assembling sequence
 Séquence d'assemblage
 Secuencia de ensamblaje
 Parts / Pièces / Piezas:

CA13A EX-681 CA09A EX-702 CA09A
 bottom / fond / fondo + CA13A 67

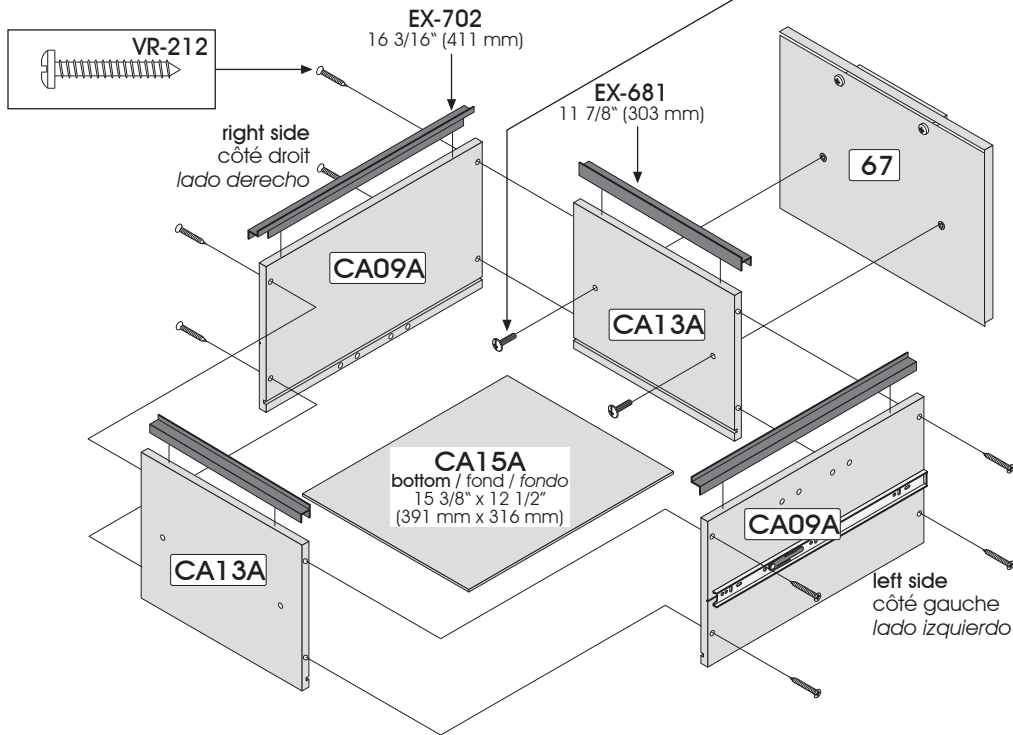
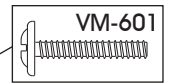

Code / Código / Piezas	EX-681	EX-702	VM-601	VR-212
Qty / Qté / Cant. de Piezas	2	2	2	8

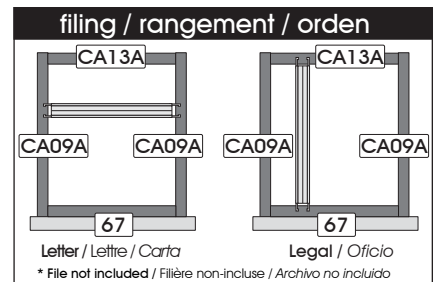

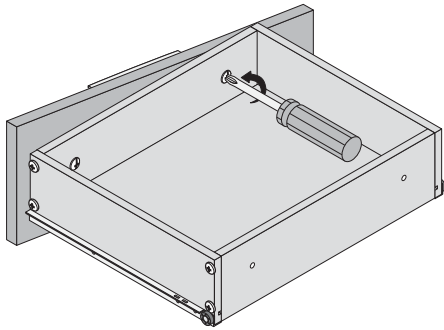

After installing drawers into cabinet, adjust drawer fronts and tighten screws VM-601.

Après avoir installé les tiroirs dans le meuble, ajustez les devants de tiroirs et resserrez les vis VM-601.

Después de instalar los cajones en el mueble, ajuste las partes delanteras de los cajones y vuelva atornilla a fondo los tornillos VM-601.

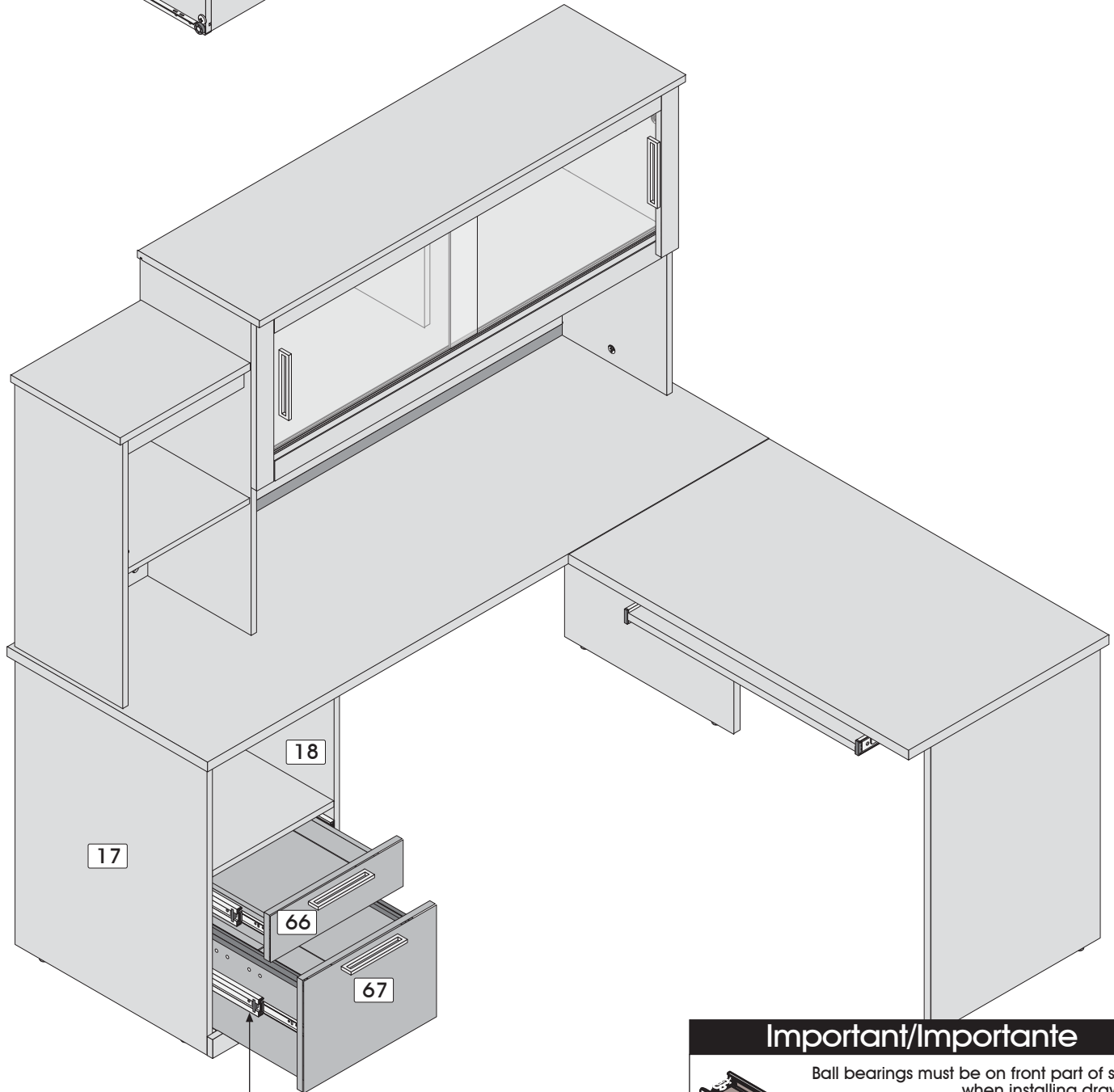

Important/Importante

Ball bearings must be on front part of slider when installing drawers.

Les roulements à billes doivent être sur la partie avant du coulisseau lors de l'installation des tiroirs.

Los cojinetes de bolas deben ubicarse sobre la parte delantera de guía en el momento de instalar los cajones.

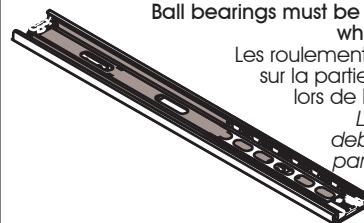

Important/Importante

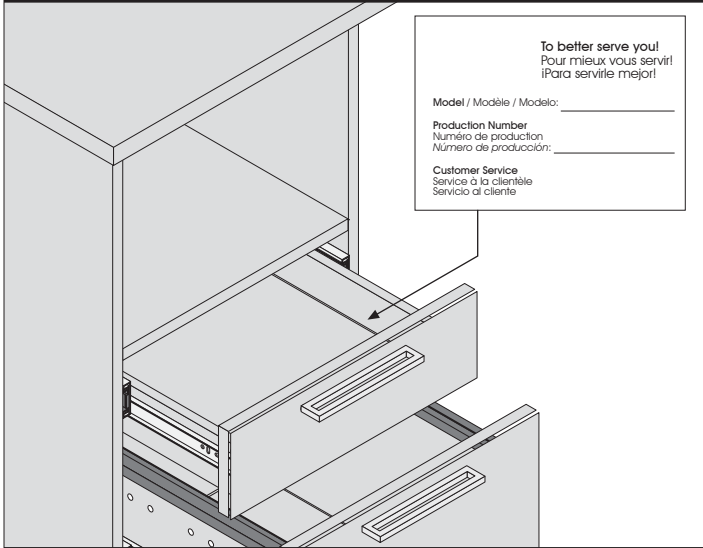

For future reference and to better serve you, please apply the self-adhesive sticker in an accessible space such as inside a drawer.

Pour mieux vous servir en cas de besoin, veuillez apposer l'autocollant dans un endroit facilement accessible tel que l'intérieur d'un tiroir.

Para futura referencia y mejor servicio, por favor aplique la etiqueta autoadhesiva en un espacio accesible como por ejemplo al interior de un cajón.

When you have completed the assembly of your new furniture, install plastic caps
Lorsque vous avez complété l'assemblage de votre meuble, installez les capuchons de plastique
Una vez que haya completado el ensamblaje del mueble, coloque los capuchones de plástico

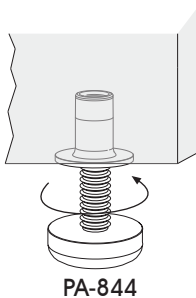
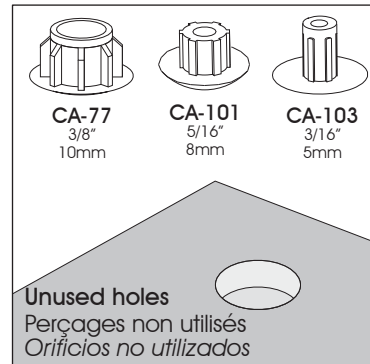
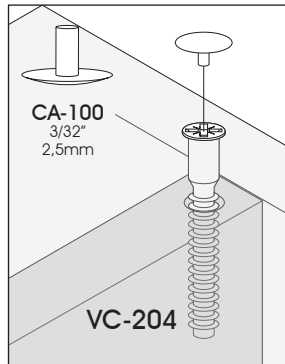
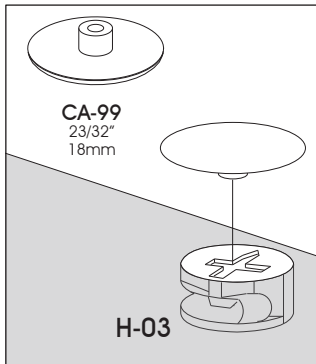

To level your furniture, use leg levelers.

Pour niveler votre meuble utilisez les pattes ajustables.

Para nivelar su mueble utilice las patas ajustables.

PRODUCT CARE / ENTRETIEN DU PRODUIT / MANTENIMIENTO DEL PRODUCTO

Avoid placing the furniture in the sunlight or near a source of heat. Use a soft dry cloth for dusting. To clean heavy dirt, use a cloth dipped in a solution of mild detergent and water. Avoid leaving wet objects on the surface or using commercial chemical cleaning products.

Évitez d'exposer le meuble au soleil ou près de toute source de chaleur. Pour le nettoyage, utilisez un chiffon doux et sec. Pour la grosse saleté, utilisez un chiffon humidifié avec un peu de détergent dilué dans l'eau. Évitez de laisser des objets mouillés sur la surface de votre meuble ou d'utiliser des nettoyeurs chimiques.

Evite exponer el mueble al sol o las fuentes de calor. Para limpiarlo, utilice un paño suave y seco. Para limpiar las manchas rebeldes, utilice un trapo húmedo con un poco de detergente diluido en agua. No deje objetos mojados encima del mueble ni utilice limpiadores que contengan productos químicos.

CONGRATULATIONS! YOU ARE NOW THE OWNER OF A QUALITY PRODUCT
FÉLICITATIONS! VOUS AVEZ MAINTENANT EN VOTRE POSSESSION UN PRODUIT DE QUALITÉ
FELICITACIONES! AHORA ES USTED DUEÑO DE UN PRODUCTO DE CALIDAD.

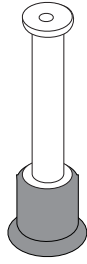

You are at a step of hardware installation and some H-36 are missing:

Before calling to order your missing bolts (H-36), please make sure you have not installed any bolts (H-36) in the wrong place. To remove a bolt (H-36) which is not in the correct place, please refer to your instruction manual.

Vous êtes à une étape d'installation de quincaillerie et il vous manque des H-36 :

Avant d'appeler pour commander des boulons (H-36), assurez-vous de ne pas avoir installé des boulons (H-36) au mauvais endroit. Pour enlever un boulon (H-36) mal situé, consultez le feuillet d'instructions

Usted está en alguna etapa de la instalación de quincallas y le faltan las H-36 :

Antes de llamar para pedir los pernos (H-36), asegúrese de que no los haya instalado en el lugar equivocado. Para retirar un perno (H-36) mal puesto, consulte el folleto de instrucciones

How to separate and install your CO-249 and CO-684 slides:

The CO-249 & CO-684 slides consist of two sections which you must separate. To separate the slides, please refer to your instruction manual. The slides are installed on distinct parts which will be re-grouped only when the drawers are installed on the furniture.

Comment séparer et installer les coulisseaux CO-249 et CO-684 :

Les coulisseaux CO-249 et CO-684 sont constitués d'une partie que vous devez séparer en deux sections. Pour séparer le coulisseau, référez-vous au feuillet d'instructions. Les coulisseaux sont installés sur deux pièces distinctes et seront regroupés seulement lors de l'installation des tiroirs dans le meuble.

Cómo separar y instalar las guías correderas CO-249 y CO-684 :

Las guías correderas CO-249 y CO-684 están constituidas por una parte que usted debe separar en dos secciones. Para separar las guías correderas, consulte el folleto de instrucciones. Las guías correderas se instalan en dos piezas distintas y sólo serán reagrupadas una vez que se instalen los cajones en el mueble.

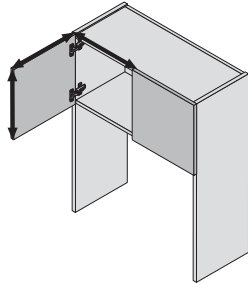
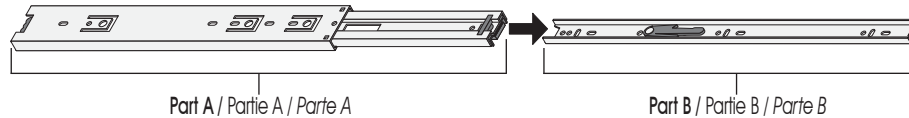

The doors on your furniture are crooked or the space between the doors is uneven:

It is very important to install the hinges and hinge plates on the correct parts while respecting the instruction manual. For the installation and adjustment of the doors, please refer to your instruction manual or log on to the internet site

Les portes de votre meuble sont croches ou l'espace qui les sépare est inégal:

Il est important d'installer les pentures et les plaques sur les bonnes pièces en respectant le feuillet d'instructions. Pour l'installation des portes et leur ajustement, référez-vous à l'étape d'installation des portes dans le feuillet d'instructions ou sur le site internet de .

Las puertas de su mueble están chuecas o el espacio que las separa es desigual:

Es importante instalar las bisagras y las placas sobre las piezas adecuadas respetando el folleto de instrucciones. Para la instalación de las puertas y su ajuste, consulte la etapa de instalación de las puertas en el folleto de instrucciones o en el sitio Internet de .

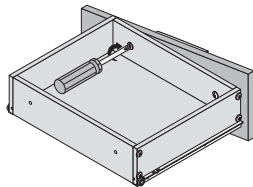

The drawers on your furniture are crooked or the space between the drawers is uneven:

While referring to the section indicating the actual sizes of the screws in your instruction manual, please insure that you are using the correct size screws needed when installing your drawer slides and drawer fronts. They must be installed straight. While installing the drawer front, make sure that the correct side is facing up. For the adjustment of the drawer fronts, please refer to your instruction manual or log on to the internet site

Les tiroirs de votre meuble sont croches ou l'espace qui les sépare est inégal :

En vous référant au tableau de vis grandeur réelle du feuillet d'instructions, assurez-vous que vous avez utilisé les bonnes vis lors de l'installation des coulisseaux ainsi que du devant de tiroir et qu'elles sont posées bien droites. Assurez-vous également que le devant du tiroir n'est pas assemblé à l'envers. Référez-vous à l'étape d'ajustement des tiroirs dans le feuillet d'instructions ou sur le site internet de .

Los cajones de su mueble están chuecos o el espacio que los separa es desigual :

Consulte la tabla de tornillos en tamaño real del folleto de instrucciones y asegúrese de que haya utilizado los tornillos adecuados durante la instalación de las guías correderas así como también la parte delantera del cajón y que éstos estén puestos bien derechos. Asegúrese también de que la parte delantera del cajón no esté ensamblada al revés. Consulte la etapa del ajuste de cajones en el folleto de instrucciones o en el sitio Internet de .