

Tremont™  
Shorewood™  
Bradford™  
Cottage Grove™  
Rochester™  
Brookstone™  
Greenbriar™  
Avalon™  
Tahoe™  
Mansfield™  
Amherst™

POCKET BILLIARD TABLE  
INSTALLATION MANUAL



[www.brunswick-billiards.com](http://www.brunswick-billiards.com)  
SERVICE DEPARTMENT P.O. BOX 68 BRISTOL, WI 53104

Shorewood™  
Bradford™  
Cottage Grove™  
Rochester™  
Brookstone™  
Greenbriar™  
Avalon™  
Tahoe™  
Mansfield™  
Amherst™

POCKET BILLIARD TABLE  
INSTALLATION MANUAL



[www.brunswick-billiards.com](http://www.brunswick-billiards.com)  
SERVICE DEPARTMENT P.O. BOX 68 BRISTOL, WI 53104

NOTE: Please use the instructions in this manual to assemble the tables.  
Illustrations may be different depending on the table being assembled.  
Also note that careful handling of *all* components  
will assure damage-free assembly.



# LEG AND BASEFRAME ASSEMBLY

- SHOREWOOD • TAHOE • BRADFORD • COTTAGE GROVE
- ROCHESTER • BROOKSTONE • GREENBRIAR
- AVALON • TAHOE • MANSFIELD • AMHERST

FIGURE ONE A AND B

*Step #1:* Position the side sills with the inside up on a flat protected surface. Loosely attach two cross support brackets to each side sill using 5/16-18 x 3/4" hex head cap screws and 5/16 washers.

*Step #2:* With a straight edge or block flat across the slate attach plate. Slide the bracket up to make contact and tighten securely. It is critical that the top of the bracket is flush with the top surface of slate attach plate.

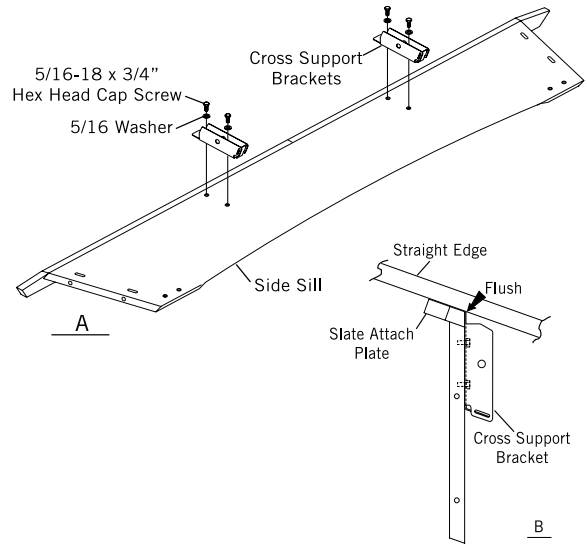

FIGURE ONE

FIGURE TWO

*Step #3:* Loosely attach the corner brackets to the ends of the side sills using 5/16-18 x 1-3/4" hex head cap screws, 5/16 washers and 5/16-18 tab weld nuts.

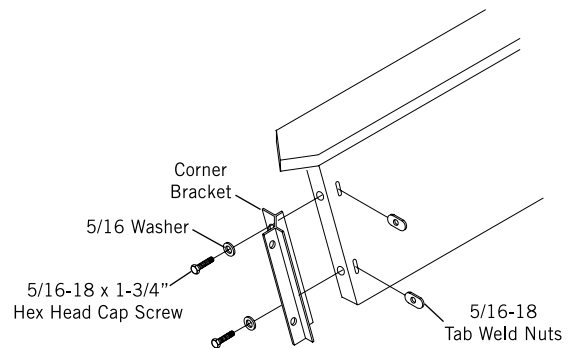

FIGURE TWO

FIGURE THREE

*Step #4:* Position the baseframe end sills to the side sills, and loosely attach the brackets already attached to the side sills with the same hardware.

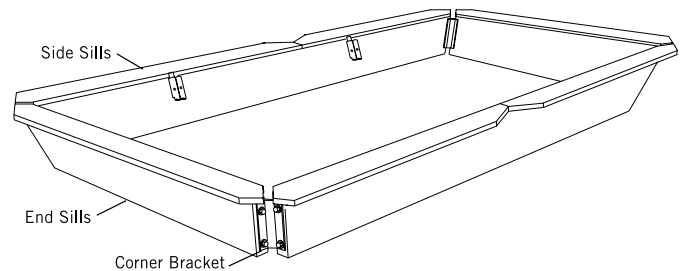

FIGURE THREE



# LEG AND BASEFRAME ASSEMBLY (CONTINUED)

- SHOREWOOD • TAHOE • BRADFORD • COTTAGE GROVE
- ROCHESTER • BROOKSTONE • GREENBRIAR
- AVALON • TAHOE • MANSFIELD • AMHERST

FIGURE FOUR

*Step #5:* Loosely attach the leg attach brackets to the baseframe using 5/16-18 x 3/4" hex head cap screws and 5/16 washers.

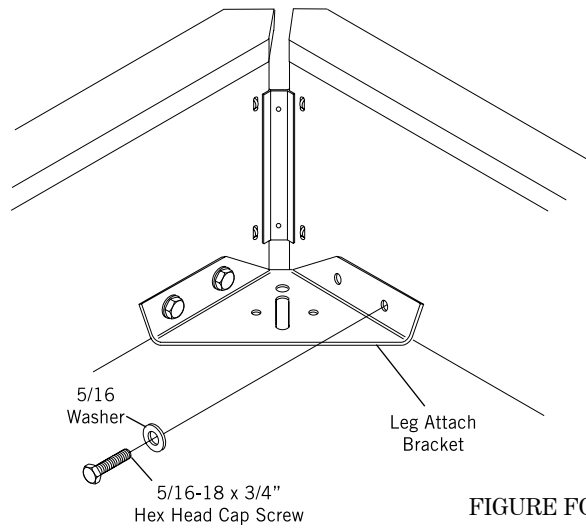

FIGURE FOUR

FIGURES FIVE AND SIX

*Step #6:* With the aide of another person, carefully place the baseframe on top of the legs and loosely attach using 5/16-18 x 1" hex head cap screws and 5/16" washers.

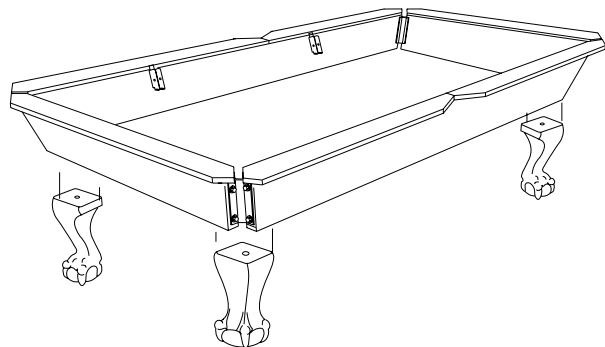

FIGURE FIVE

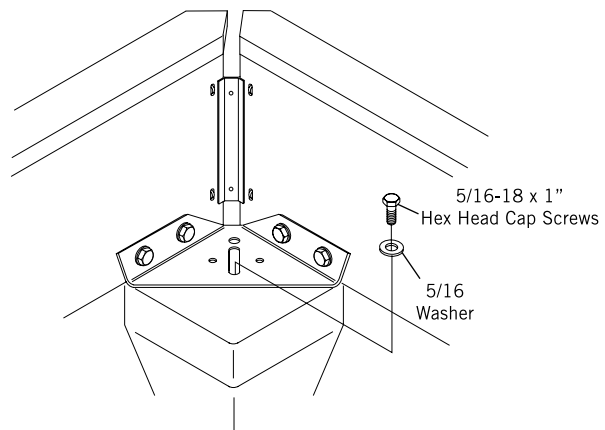

FIGURE SIX



# LEG AND BASEFRAME ASSEMBLY CONTINUED

- SHOREWOOD • TAHOE • BRADFORD • COTTAGE GROVE
- ROCHESTER • BROOKSTONE • GREENBRIAR
- AVALON • TAHOE • MANSFIELD • AMHERST

FIGURE SEVEN

*Step #7:* Position the cross supports into the brackets and loosely attach using 3/8-16 x 2" hex head cap screws, 3/8 washers, and 3/8-16 hex nuts. Assure that the cross supports are flush with the top to the sills and tighten securely. If necessary, remove wood from the bottom of the cross support or place shims in the bottom of the brackets to obtain a flush fit.

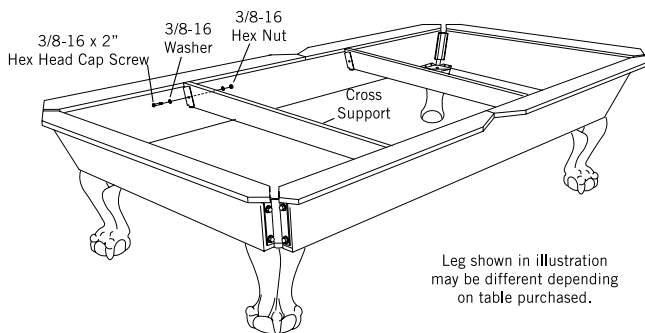

*Step #8:* Square the table using a carpenter's square and assure that the baseframe is sitting flush on the leg top and securely tighten all corner brackets. Firmly push downward on the baseframe and securely tighten the leg attach brackets.

FIGURE SEVEN

FIGURE EIGHT

*Step #9:* Position the corner post over the baseframe. While using the two holes in the center of the corner bracket, pilot drill 1/8" diameter holes into the corner post. (Be careful not to drill all the way through.) Hold the corner post firmly in position and attach using #8 x 1-1/4" round head screws and #8 washers.

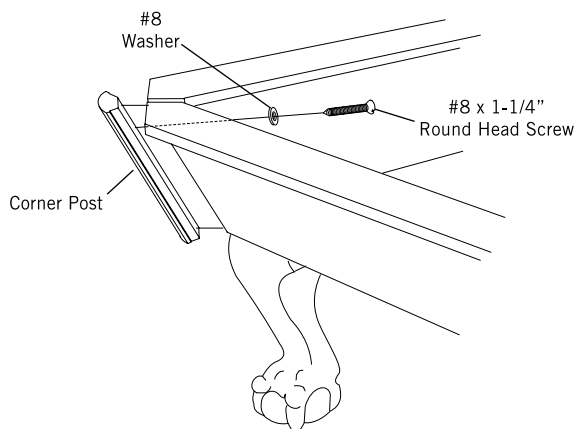
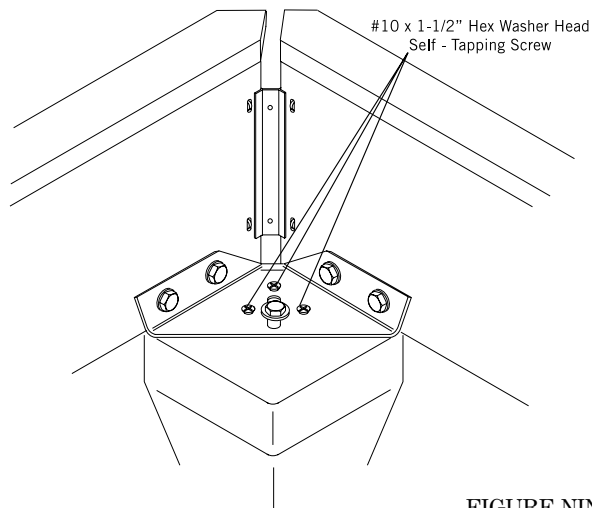

FIGURE EIGHT

FIGURE NINE

*Step #10:* At each corner, adjust the legs to the desired location and securely tighten the center bolt to the leg. While using the three remaining holes in each leg attach bracket as a template, pilot drill 1/8" diameter holes into the legs approximately 1-1/2" deep. Complete the attachment of the leg bracket using #10 x 1-1/2" hex washer head self-tapping screws.



*Step #11:* Position the table in its permanent location. We recommend a 60" clearance around perimeter of the table. Proceed with leveling and slate installation.

FIGURE NINE



# SLATE ASSEMBLY AND LEVELING

- SHOREWOOD • TAHOE • BRADFORD • COTTAGE GROVE
- ROCHESTER • BROOKSTONE • GREENBRIAR
- AVALON • TAHOE • MANSFIELD • AMHERST

**IMPORTANT:** Prior to installing the slate, it is important to level the baseframe.

## FIGURE ONE

**Step #1:** With a carpenter's level, locate the highest corner of the baseframe. Level the baseframe by positioning shims (supplied with the table) underneath the other three legs as necessary.

**Step #2:** Be sure that the top surfaces are absolutely flush. Add shims under the legs as necessary to accomplish this.

**Step #3:** With the baseframe level and carefully positioned in its permanent location, place the center section of slate on the table. Be sure that the center section is precisely square with the frame and an equal amount of overhang exists on both sides of the table.

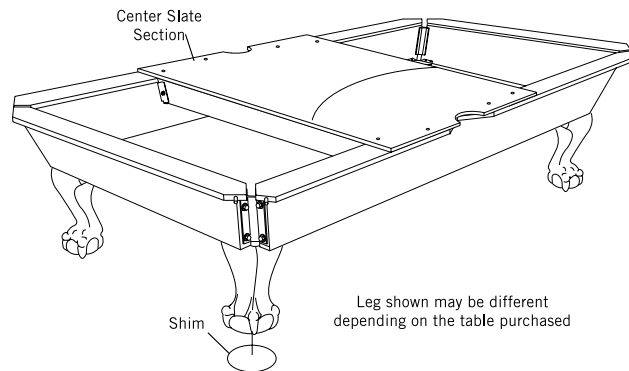

FIGURE ONE

## FIGURE TWO

**Step #4:** Position the two end slate sections on the baseframe. Be sure that the penciled arc forms a radius.

**Step #5:** Recheck to be sure that the slate has an equal amount of overhang around the baseframe.

**Step #6:** Using the twelve (12) countersunk holes in the slate as a template, pilot drill 5/32" diameter holes into slate attach plate.

**Step #7:** Securely fasten the end slate section at both ends of the table.

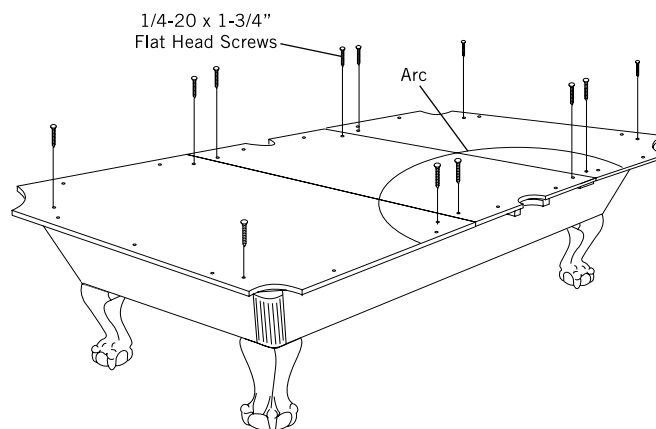

Framed Slate Use #14 x 2-1/2" Flat Head Screws  
Unframed Slate Use 1/4-20 x 1-3/4" Flat Head Screws

FIGURE TWO



## SLATE ASSEMBLY AND LEVELING (CONTINUED)

• SHOREWOOD • TAHOE • BRADFORD • COTTAGE GROVE  
• ROCHESTER • BROOKSTONE • GREENBRIAR  
• AVALON • TAHOE • MANSFIELD • AMHERST

FIGURE THREE

*Step #8:* With a precision level, level each end slate section by driving wooden slate wedges (provided) between the top of the baseframe and bottom of the slate. Keep the wedges as close to the countersunk holes as possible. (Loosen and tighten screw as required.)

*Step #9:* With both end slates perfectly level, continue fastening the end slates at the joints. Recheck for levelness and if necessary, back the screws out and adjust the shim position, then retighten the slate attaching screws.

*Step #10:* When satisfied that both end slates are level, shim the center slate section as required to obtain a flush fit at both joints, then screw the center slate down.

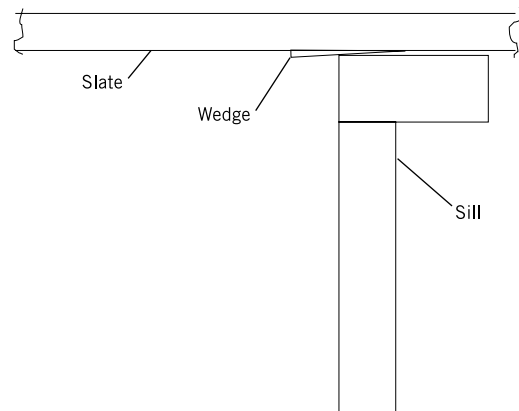

FIGURE THREE

FIGURE FOUR

*Step #11:* Slate joints can now be filled with fast setting rock hard putty, bee's wax or slate joint wax. Lightly sand or scrape across joint after grouting.

*Step #12:* From the end of a bed cloth, cut strips of cloth approximately 1-1/2" wide by approximately 8" long and glue the strips to the pocket cutouts (3m Super 77 is recommended for this step). This is important as this will provide cushioning from ball impact and the bed cloth will last much longer.

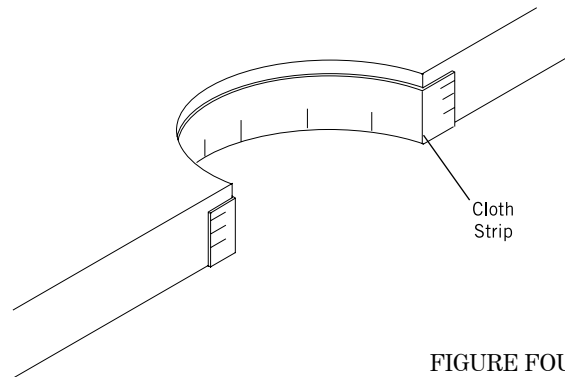

FIGURE FOUR



# ATTACHING BED CLOTH

• SHOREWOOD • TAHOE • BRADFORD • COTTAGE GROVE  
• ROCHESTER • BROOKSTONE • GREENBRIAR  
• AVALON • TAHOE • MANSFIELD • AMHERST

Before attaching bed cloth clean slate thoroughly:

FIGURE ONE

*Step #1:* Lay the bed cloth over the top of the slate, nap side up. Leave an equal amount of cloth overhang at the end and sides of the slate.

**NOTE:** In determining the direction of the nap, run your hand lightly over the surface of the cloth. If it meets resistance, it is going against the nap.

*Step #2:* Adjust cloth to leave only enough cloth overhang at the head end and left side to permit tacking into the wood slate frame. Leave the balance of cloth overhang at the foot end and right side.

**NOTE:** Do not spread tacks or staples on the bed cloth because it could cut the cloth. Keep them in a container that slides over the cloth.

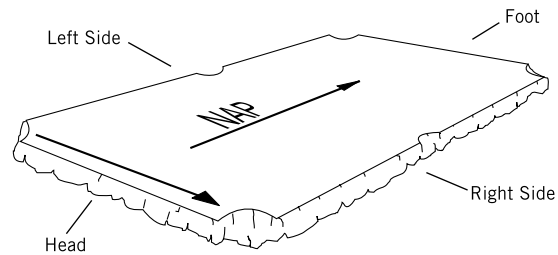

FIGURE ONE

FIGURE TWO

*Step #3:* Tack or staple the cloth securely to the wood frame at location #1 with two tacks or staples approximately 2" apart.

*Step #4:* Stretch the cloth across the table and tack or staple securely at location #2 with two tacks or staples 2" apart.

*Step #5:* Stretch the cloth from location #1 to location #3 and tack or staple securely into the wood frame at the left side of the table.

*Step #6:* Stretching the cloth across the table from location #3 and pulling from location #2, tack or staple the cloth at location #4.

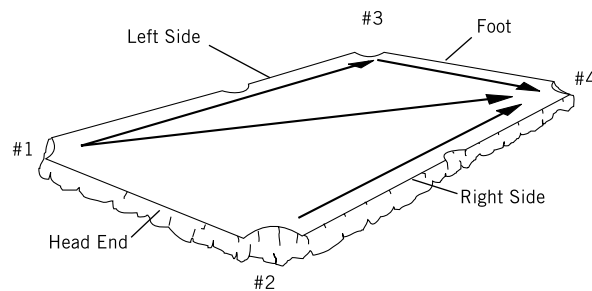

FIGURE TWO

FIGURE THREE

*Step #7:* On the left side, stretch the cloth tightly from location #1 toward the side pocket opening and tack or staple securely at location #5.

*Step #8:* Repeat Step 5, stretching the cloth from location #3 and tacking or stapling at location #6.

*Step #9:* On the right side of the table, grasp the cloth firmly and stretch across the table from location #5 and toward the side pocket from location #2 and tack or staple at location #7.

*Step #10:* Repeat Step 9, stretching from location #6 and toward the side pocket from location #4 and tack or staple at location #8.

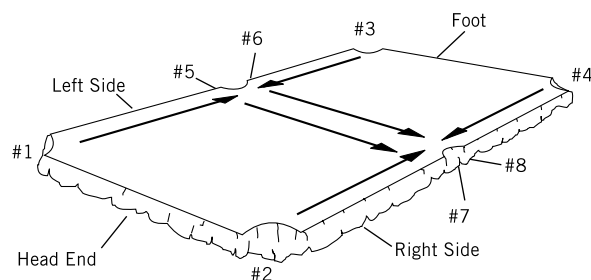

FIGURE THREE



## ATTACHING BED CLOTH (CONTINUED)

• SHOREWOOD • TAHOE • BRADFORD • COTTAGE GROVE  
• ROCHESTER • BROOKSTONE • GREENBRIAR  
• AVALON • TAHOE • MANSFIELD • AMHERST

FIGURE FOUR

*Step #11:* At location #9, cut a short slit in the cloth at the edge centered on the side pocket opening. Grasp the cloth firmly above this slit, pull the cloth into the side pocket opening and tack or staple to the wood frame. Complete fastening of the cloth to the side pocket opening, making sure the cloth is tacked or stapled to the wood frame.

*Step #12:* Stretching the cloth tightly across the table from location #9, repeat Step 11 at location #10.

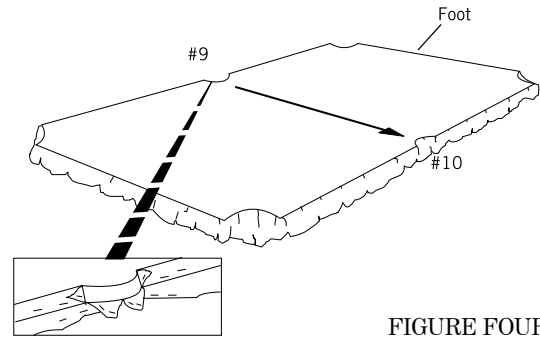

FIGURE FOUR

FIGURE FIVE

*Step #13:* At the head end of the table, tack or staple the cloth at location #11, maintaining uniform overhang.

*Step #14:* Pull the cloth from location #11 toward location #12 and tack or staple securely along the wood frame, keeping the cloth even along the head end.

*Step #15:* Stretch the cloth firmly from location #11 to the foot end of the table and tack or staple at location #13.

*Step #16:* Stretch the cloth tightly from locations #12 and #13 toward location #14 and tack or staple securely along the wood slate frame.

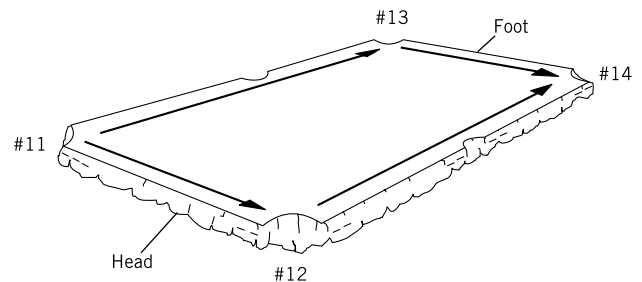

FIGURE FIVE

FIGURE SIX

*Step #17:* Tack or staple all of the left side on 2" centers keeping the cloth even along the wood frame.

*Step #18:* Tack or staple the balance of the head end on 2" centers also keeping the cloth even along the wood frame.

*Step #19:* Stretch the cloth tightly toward the foot end of the table, tacking or stapling on 2" centers along the wood frame at the foot end.

*Step #20:* Stretch the cloth tightly across the table to the right side, tacking or stapling on 2" centers all the way along the wood frame at the right side.

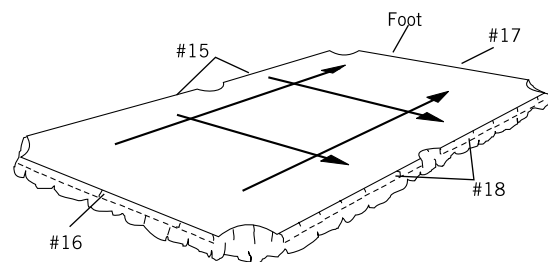

FIGURE SIX

FIGURE SEVEN

*Step #21:* Stretch the cloth into the corner pocket openings and tack or staple to the wood slate frame.

*Step #22:* Trim off excess cloth around the perimeter of the slate. Locate the eighteen (18) rail attach holes and cut clearance holes in the cloth with a sharp knife.

**NOTE:** Occasionally cloth will stretch, leaving wrinkles at the pockets. To retighten, remove apron, one end rail and one side rail. Pull cloth taut, and retack or restaple along the open end and side to restore original tightness.

Cut holes in cloth at rail both locations.

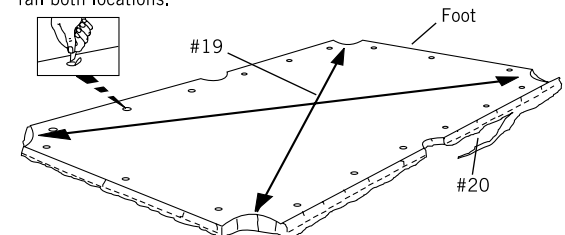

FIGURE SEVEN

# ATTACHING RAIL CLOTH

• SHOREWOOD • TAHOE • BRADFORD • COTTAGE GROVE  
• ROCHESTER • BROOKSTONE • GREENBRIAR  
• AVALON • TAHOE • MANSFIELD • AMHERST

## CORNER POCKET FIGURE ONE

*Step #1:* Place cloth on rail with the back side down. The cloth should have equal amount of overhang at both ends of rail and extend 1/2" over the featherstrip groove on the cushion side as shown.

*Step #2:* Except for approximately 3" at end of rail, tap featherstrip down with a tapping block and hammer, starting at center of rail. Stretch cloth tightly toward each end of rail and tap featherstrip down.

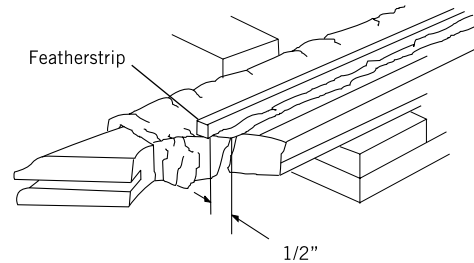

FIGURE ONE

## FIGURE TWO

*Step #3:* At each end of rail, pull the cloth toward the rubber cushion an additional 3/4". Then tap remainder of featherstrip down.

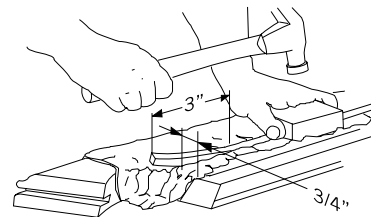

FIGURE TWO

## FIGURE THREE

*Step #4:* Trim the cloth on cushion side of featherstrip along the total length of featherstrip as illustrated.

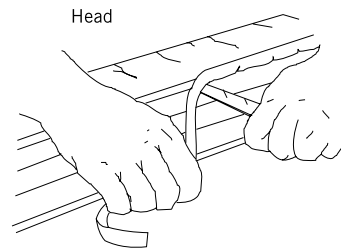

FIGURE THREE

## FIGURE FOUR

*Step #5:* Fold the cloth down over front of rail, then using thumb and forefinger as a guide along front edge of the cushion to keep the tapping block at rear edge of featherstrip, tap the featherstrip down flush with rail surface as shown.

**NOTE:** Never try to tap a featherstrip flush with just a hammer as you will surely dent the rail surface behind the featherstrip.

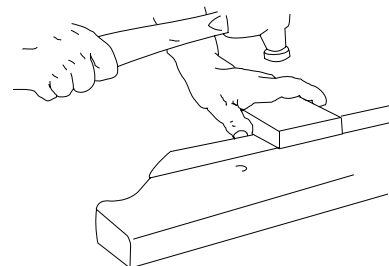

FIGURE FOUR

## FIGURE FIVE

*Step #6:* Turn rail over and at corner pockets fold the cloth over the mitred edge as shown, stretching tightly and working out any wrinkles as you staple three places in area shown.

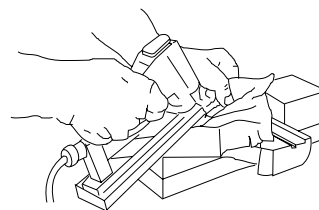

FIGURE FIVE

# ATTACHING RAIL CLOTH (CONTINUED)

• SHOREWOOD • TAHOE • BRADFORD • COTTAGE GROVE  
• ROCHESTER • BROOKSTONE • GREENBRIAR  
• AVALON • TAHOE • MANSFIELD • AMHERST

FIGURE SIX

*Step #7:* Staple three places along the rear edge of the pocket facing (X in FIGURE SIX), then trim off excess cloth at pocket area.

*Step #8:* If rail is an end rail, repeat Step 7 at other corner pocket. Then, starting at center of rails, stretch cloth tightly over cushion and staple at bottom of rail working toward each end.

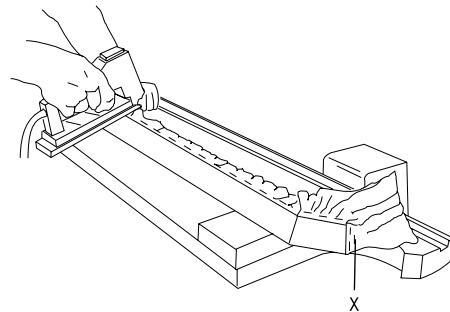

FIGURE SIX

FIGURE SEVEN

*Step #9:* Trim excess cloth from bottom of rail flush with edge of cloth relief groove.

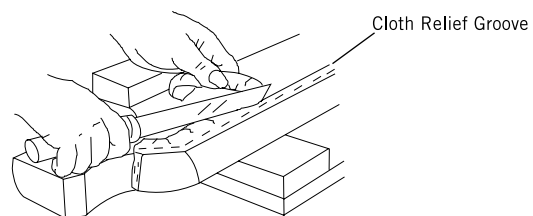

FIGURE SEVEN

## SIDE POCKET

FIGURE EIGHT

*Step #10:* At side pocket, stretch the cloth tightly over nose of cushion and staple three places as shown.

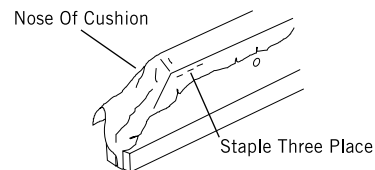

FIGURE EIGHT

FIGURE NINE

*Step #11:* Slit the cloth up to the edge of cushion nose as shown. Then firmly pull the small strip to the rear of the cushion and staple at rear of facing.

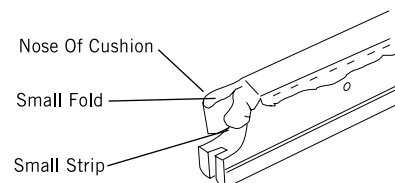

FIGURE NINE

FIGURE TEN

*Step #12:* Hold the small fold in place with thumb and forefinger and firmly hold it down over facing. Then staple at rear of facing and at bottom of rail as shown.

*Step #13:* Trim excess cloth as required.

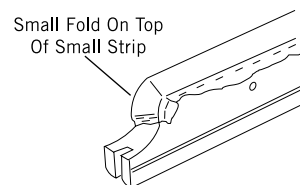

FIGURE TEN

# RAIL ASSEMBLY

- SHOREWOOD • TAHOE • BRADFORD • COTTAGE GROVE
- ROCHESTER • BROOKSTONE • GREENBRIAR
- AVALON • TAHOE • MANSFIELD • AMHERST

FIGURE ONE

*Step #1:* Position rails upside down on a protected surface in their respective locations.

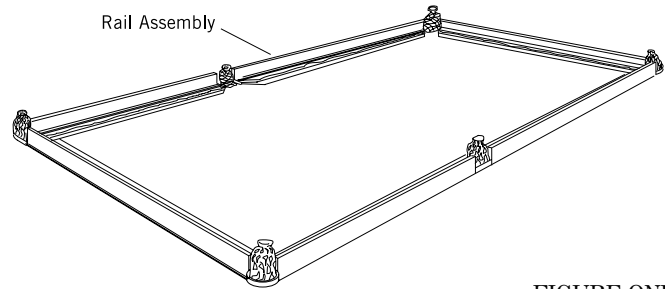

FIGURE ONE

FIGURE TWO

*Step #2:* Insert stud of pocket iron into the end of the rail as shown. Press in tightly against the end on the rail while threading a 5/16-18 x 1" hex head bolt with washer into the threaded hole in the stud. Tighten securely.

*Step #3:* Repeat above procedure with the remaining five pockets.

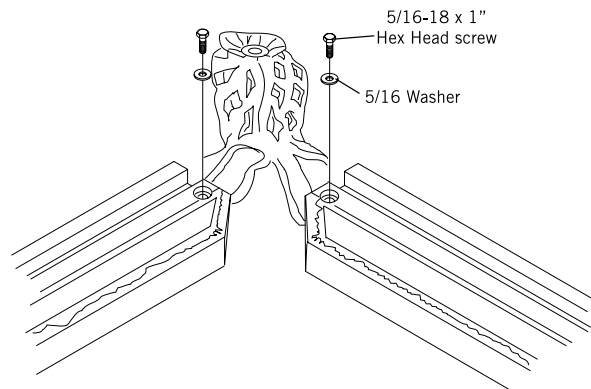

FIGURE TWO

FIGURE THREE

*Step #4:* Thread a machine stud into the three locations of each rail as shown.

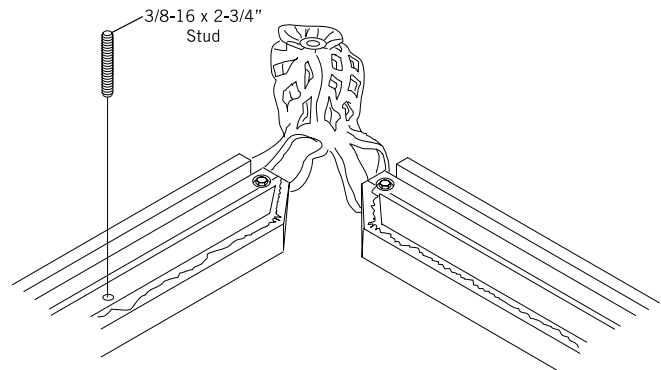

FIGURE THREE



# APRON ASSEMBLY

- SHOREWOOD • TAHOE • BRADFORD • COTTAGE GROVE
- ROCHESTER • BROOKSTONE • GREENBRIAR
- AVALON • TAHOE • MANSFIELD • AMHERST

FIGURE ONE

*Step #1:* With rail assembly remaining upside down, position the apron brackets into the groove with the short leg of the bracket facing the back of the rail, approximately 3 - 4" from each end of the rail. With the brackets firmly seated, attach them to the back of the rail core with #6 x 3/4" flat head screws through hole line "B".

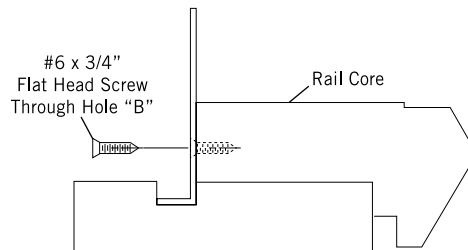

FIGURE ONE

FIGURE TWO

*Step #2:* Position the aprons into the grooves so the ends of apron and rails are even. Apply downward pressure on the apron and attach the brackets to the back of the apron with #8 x 1/2" pan head screws through hole line "A".

*Step #3:* Using a partner, carefully turn the rail and pocket assembly over and lower over the table.

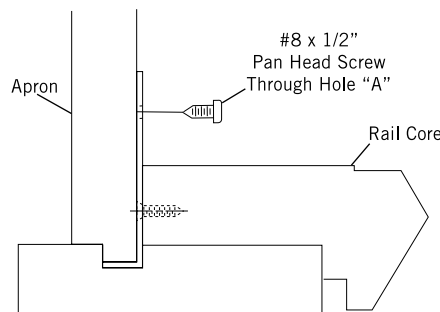

FIGURE TWO

FIGURE THREE

*Step #4:* Align the eighteen machine studs with the eighteen clearance through the slate and lower the assembly onto the slate.

*Step #5:* Thread the 3/8-16 hex nut and dome washer onto the machine stud (three places) at the ends of the table and tighten securely.

*Step #6:* Making sure that the side rails are in a straight line as sighted down the length of the table (cushion side), fasten the side rails securely with remaining nuts and dome washers.

*Step #7:* Attach pocket tabs to underside of slate frame pad with nails, or 1/2" staples.

*Step #8:* Thoroughly brush the area on which the bed spots are to be applied. Position the bed spot and firmly roll a ball over the spot to achieve good adhesion.

**NOTE:** Bed spots are self adhesive.

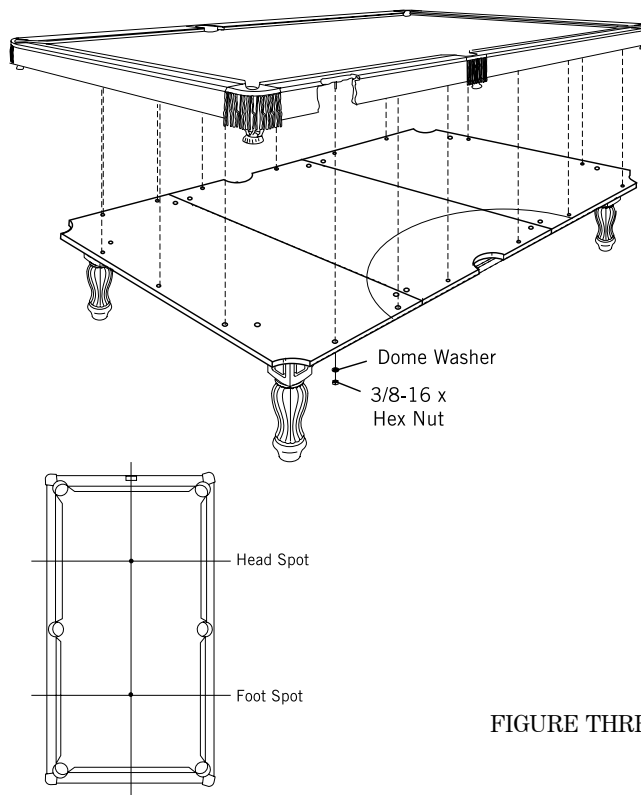

FIGURE THREE



## Shorewood Apron Installation

### Assembly instructions

Note: Study the schematic prior to starting assembly.

**Step #1:** With the rails upside down, position the brackets into the groove with the short leg of the bracket facing the back of the rail, approximately 3 - 4" from each end of the rail. With the brackets firmly seated, attach them on the underside of the rail core with #6 x 1/2" pan head screws through the holes on the short side of the bracket, as shown in Diagram #1. The #6 x 1/2" pan head screw is smaller than the #8 x 1/2" pan head screw.

**Step #2:** Position the apron into the groove so the ends of the apron and rail are even. Make sure the top of the apron is seated against the pan head screws, as shown in Diagram #1. Once in position, attach the bracket to the back of the apron with #8 x 1/2" pan head screws through hole line "A", as shown in Diagram #2.

**CAUTION: DO NOT USE #6 X 3/4" FLAT HEAD SCREW IN EITHER LOCATION.**

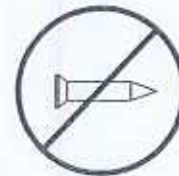
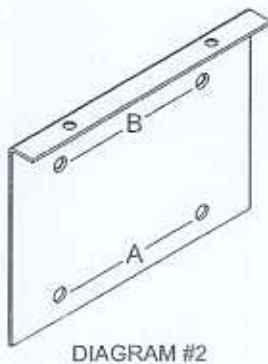
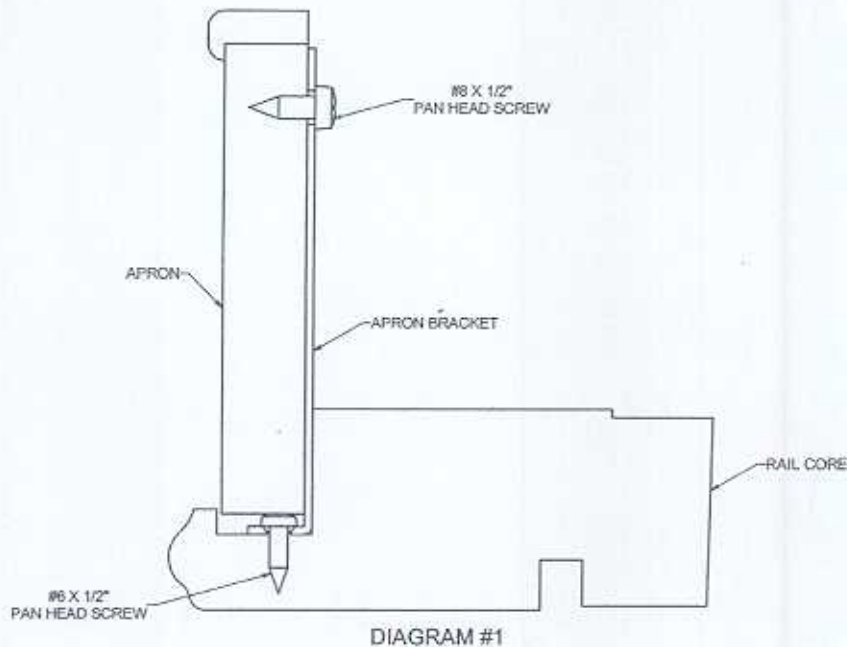

#6 X 3/4"  
FLAT HEAD SCREW