

SECRET MAPLE & CHOCOLATE : ÉRABLE SECRET ET CHOCOLAT : ARCE SECRETO Y CHOCOLATE

BORDEAUX & GRAPHITE : BORDEAUX ET GRAPHITE : BURDEOS Y GRAFITO

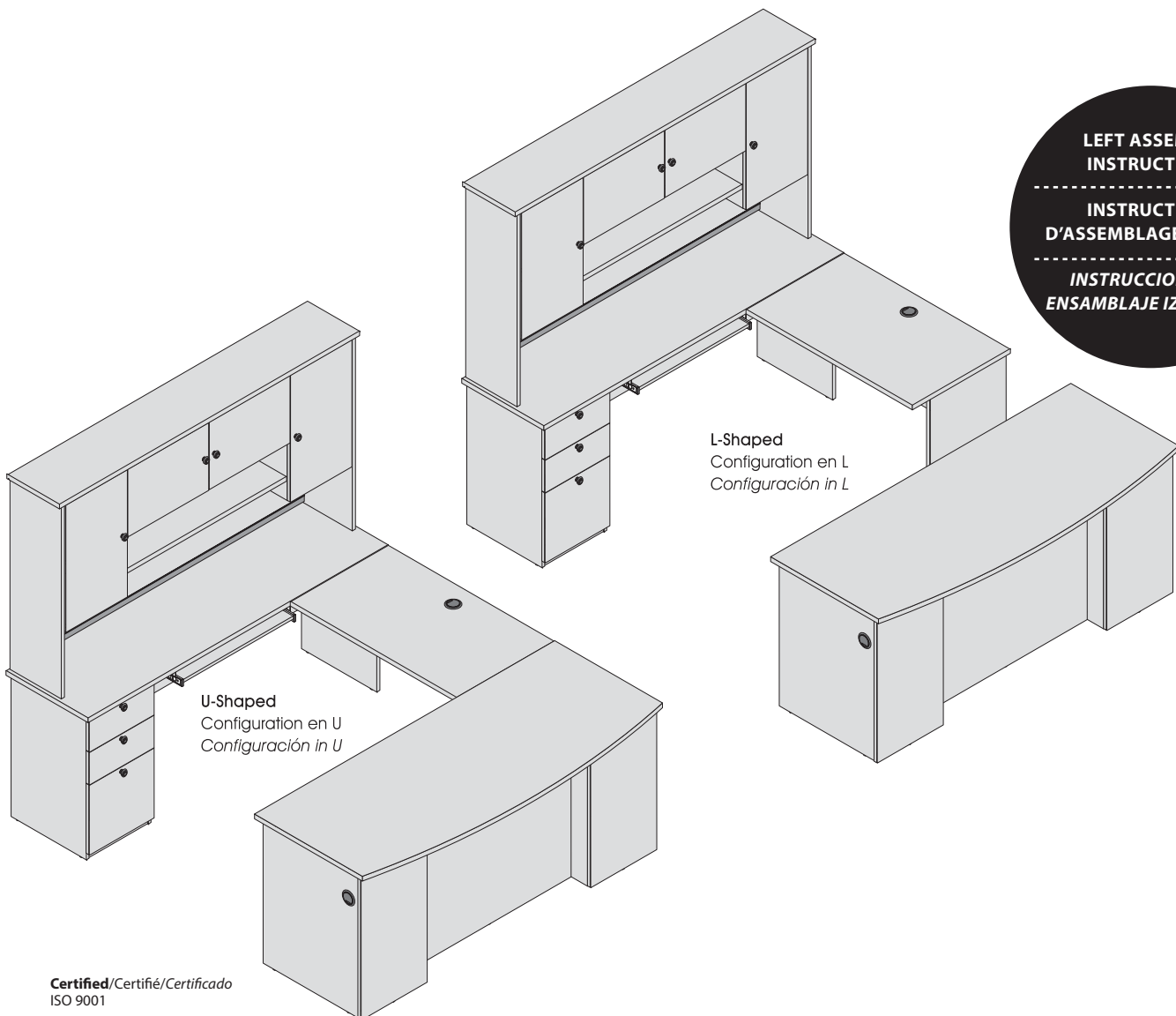

LEFT ASSEMBLY
INSTRUCTIONS

INSTRUCTIONS
D'ASSEMBLAGE GAUCHE

INSTRUCCIONES DE
ENSAMBLAJE IZQUIERDO

U-Shaped
Configuration en U
Configuración in U





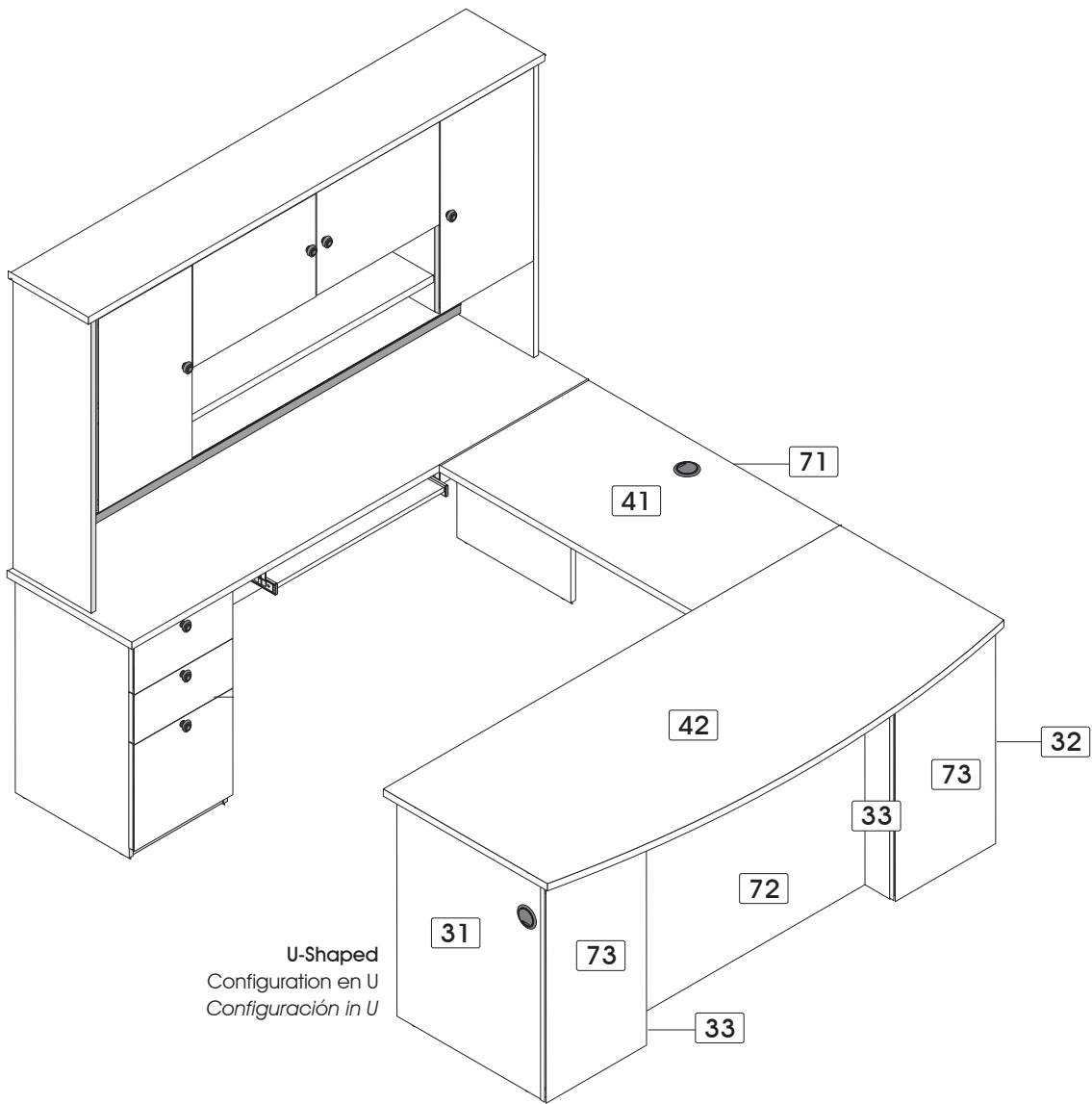

L-Shaped
Configuration en L
Configuración in L

PARTS / PIÈCES / PIEZAS

CODE / CÓDIGO	QTY / QTÉ / CANT.	CODE / CÓDIGO	QTY / QTÉ / CANT.	CODE / CÓDIGO	QTY / QTÉ / CANT.	CODE / CÓDIGO	QTY / QTÉ / CANT.
31	1	33	2	72	1	73	2
32	1	42	1				

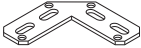

▶ **HARDWARES / QUINCAILLERIES / QUINCALLAS**

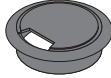
CODE / CÓDIGO	QTY / QTÉ / CANT.	CODE / CÓDIGO	QTY / QTÉ / CANT.	CODE / CÓDIGO	QTY / QTÉ / CANT.	CODE / CÓDIGO	QTY / QTÉ / CANT.
CA-99 	18	H-03 	18	PA-844  1" (25 mm)	7	VR-212  1" (25 mm)	10
EQ-143 	2	H-36 	18	PF-108 	2		

▶ **REAL SIZE / GRANDEUR RÉELLE / TAMAÑO REAL**

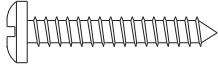
CODE / CÓDIGO	QTY / QTÉ / CANT.	CODE / CÓDIGO	QTY / QTÉ / CANT.
VR-212  1" (25 mm)	10		

▶ IMPORTANT NOTICE / NOTE IMPORTANTE / NOTA IMPORTANTE

Duly complete the self-adhesive sticker. / Assurez-vous de bien remplir l'auto-collant. / Asegúrese de completar correctamente la etiqueta.

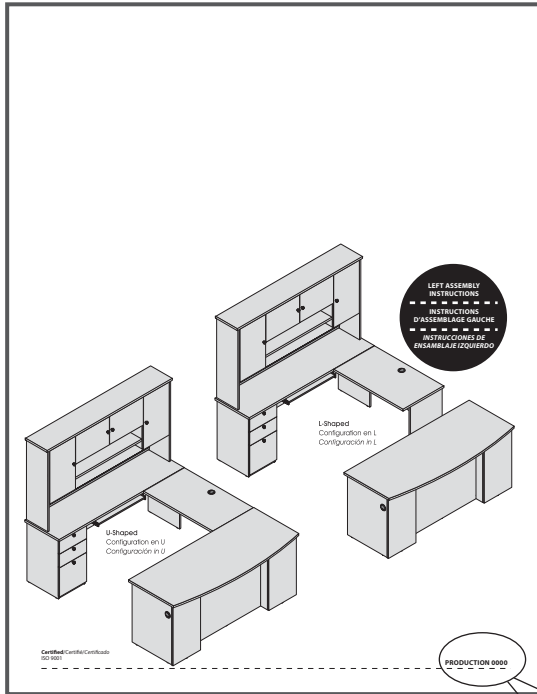

PRODUCTION 0000

To better serve you!
Pour mieux vous servir!

Model / Modèle: _____

Production Number
Numéro de production: _____

Customer Service
Service à la clientèle

Important/Importante

Please retain the self-adhesive sticker which you will install at page 26 of the instruction manual.

Conservez l'autocollant qui sera collé seulement à la page 26 du feuillet d'instructions.

Conserve la etiqueta que será pegada sólo en la página 26 de la hoja de instrucciones.

▶ IMPORTANT NOTICE / NOTE IMPORTANTE / NOTA IMPORTANTE

H-03

arrow
flèche
flecha

Insert the cam with the arrow pointing towards the hole in the edge.

Insérez la rondelle en pointant la flèche vers le trou de la bordure.

Inserte la arandela con la flecha apuntando hacia el orificio cercano al borde.

Main hardware system / Système de quincaillerie principal / Sistema principal de quincalla

1 insert / insérez / insertar

2 tools required / outils requis / herramientas necesarias

3 tighten / serrez / apretar

important
importante

How to remove a misplaced assembly bolt (H-36).
Comment retirer un boulon (H-36) mal situé.
Cómo retirar un perno (H-36) mal ubicado.

A turn / tournez / haga girar



B pull out / retirez / retire

1 **HARDWARE INSTALLATION / INSTALLATION DES QUINCAILLERIES / INSTALACIÓN DE LAS QUINCALLAS**

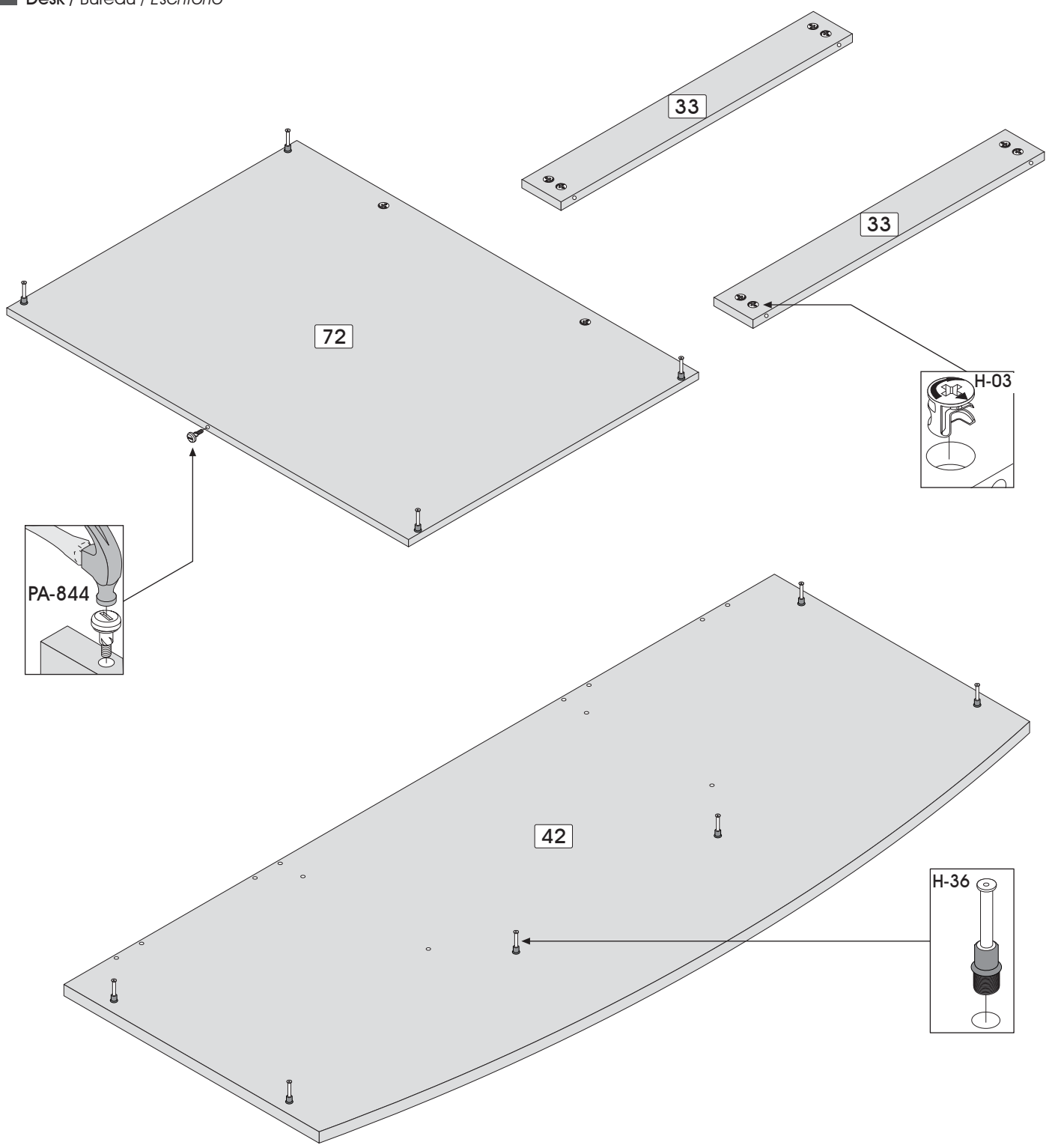
Desk / Bureau / Escritorio



1

			
Code / Código	H-03	H-36	PA-844
Qty / Qté / Cant.	x 10	x 10	x 1

2 HARDWARE INSTALLATION / INSTALLATION DES QUINCAILLERIES / INSTALACIÓN DE LAS QUINCALLAS

Desk / Bureau / Escritorio

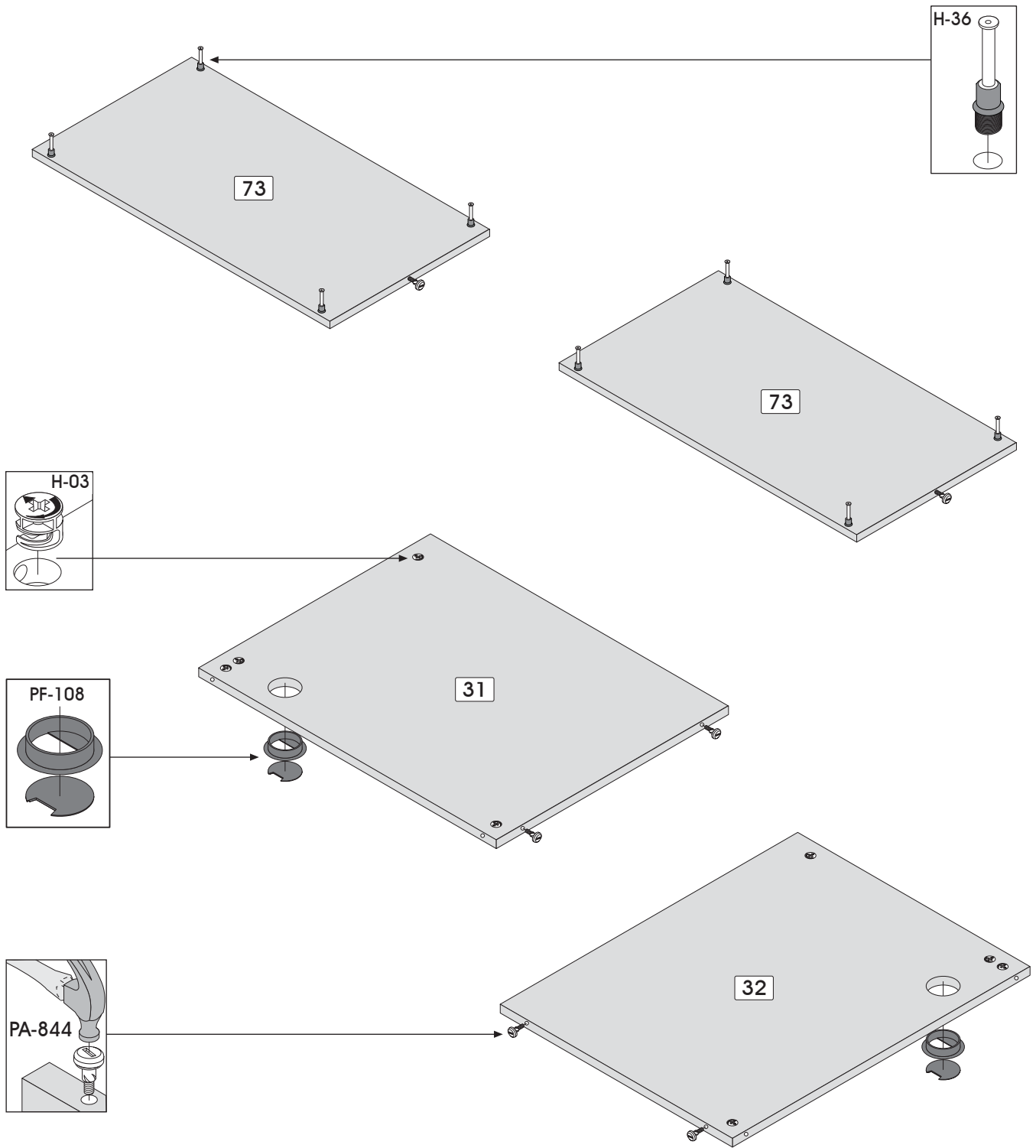

2

Code / Código

Qty / Qté / Cant.



H-03

x 8

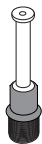

H-36

x 8



PA-844

x 6

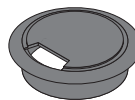

PF-108

x 2

Desk / Bureau / Escritorio

Assemble upside down

Assemblez en position renversée

Realice el ensamblaje en posición invertida

Assembling sequence

Séquence d'assemblage

Secuencia de ensamblaje

Parts / Pièces / Piezas:

72 33 33 73 73 31 32 42

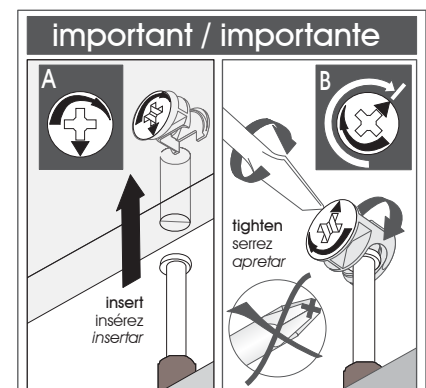
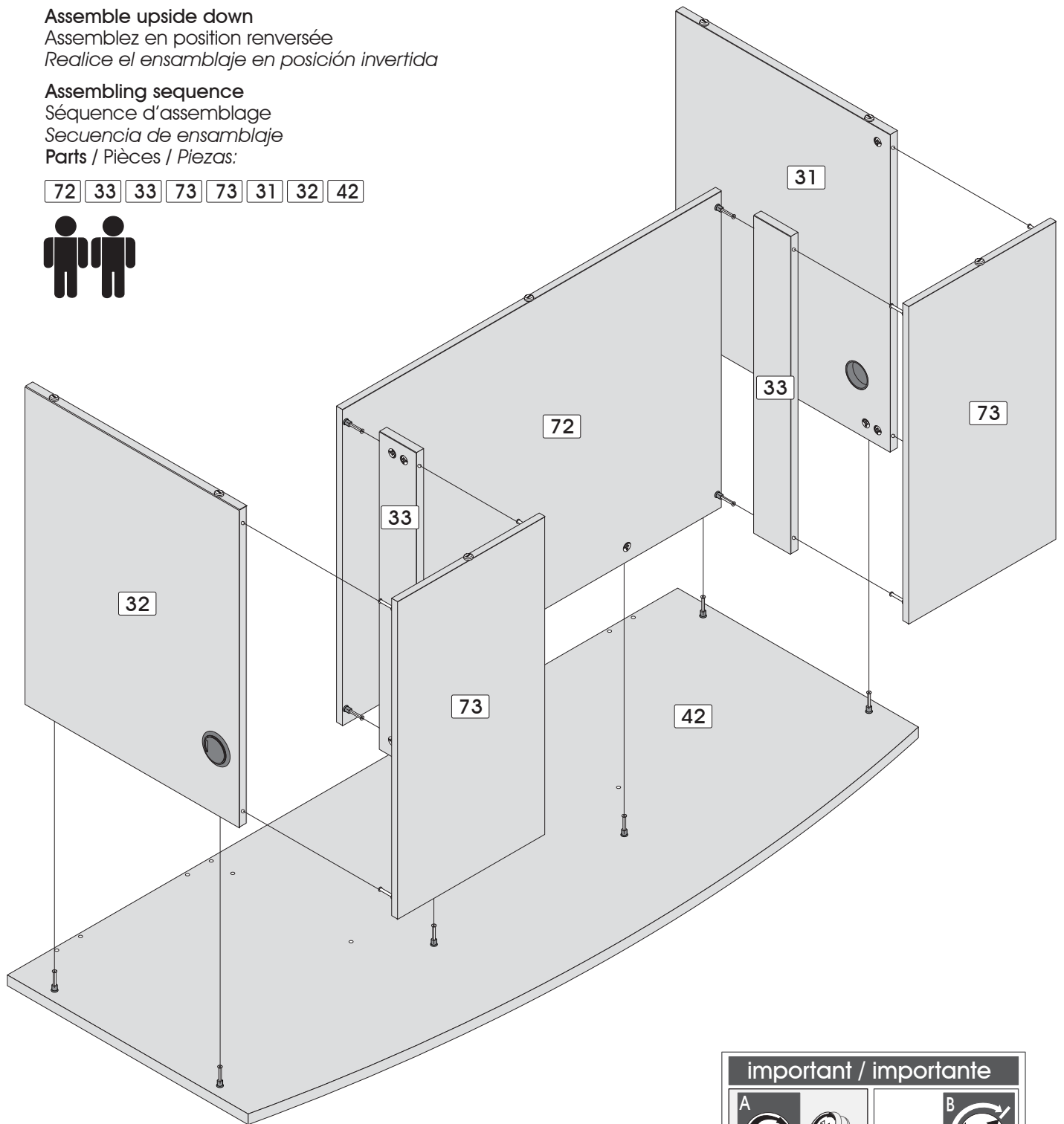

IMPORTANT/IMPORTANTE

2 possibilities for left assembly / 2 possibilités pour l'assemblage gauche / 2 posibilidades para el ensamblaje izquierdo

For L-Shape configuration, please refer to page 13.

Pour la configuration en L, référez-vous à page 13.

Para la configuración en L, vea la página 13.

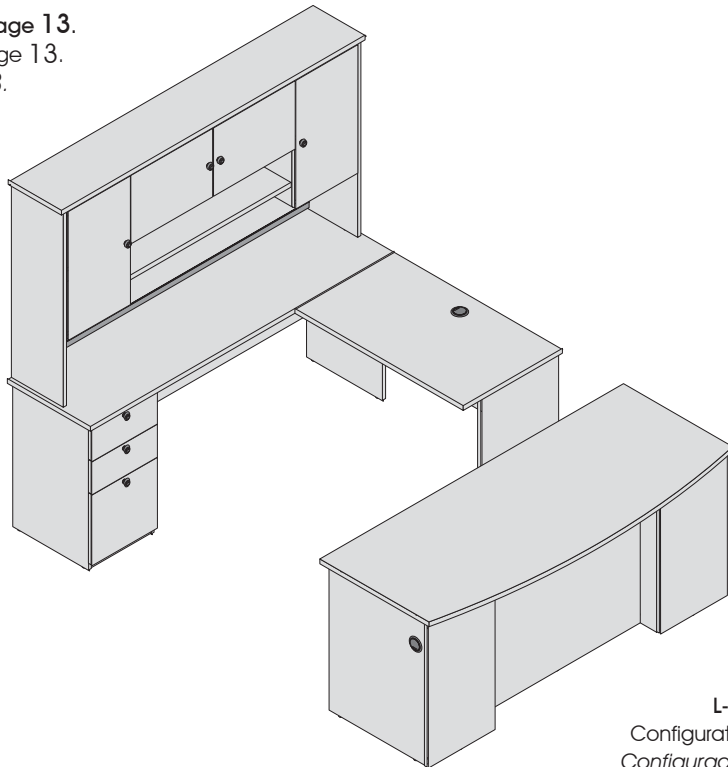

L-Shaped
Configuration en L
Configuración en L

For U-Shape configuration, please refer to pages 9-12.

Pour la configuration en U, référez-vous aux pages 9-12.

Para la configuración en U, vea las páginas 9-12.

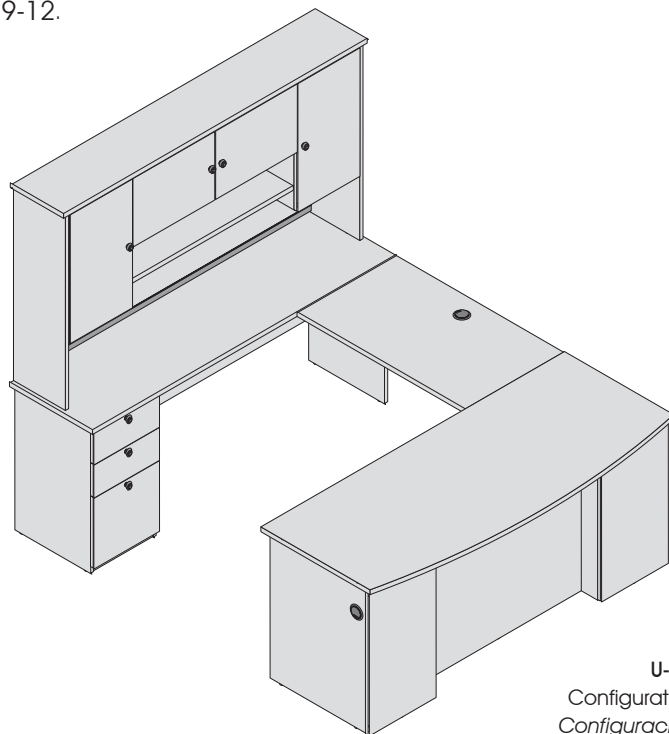

U-Shaped
Configuration en U
Configuración en U

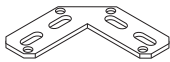
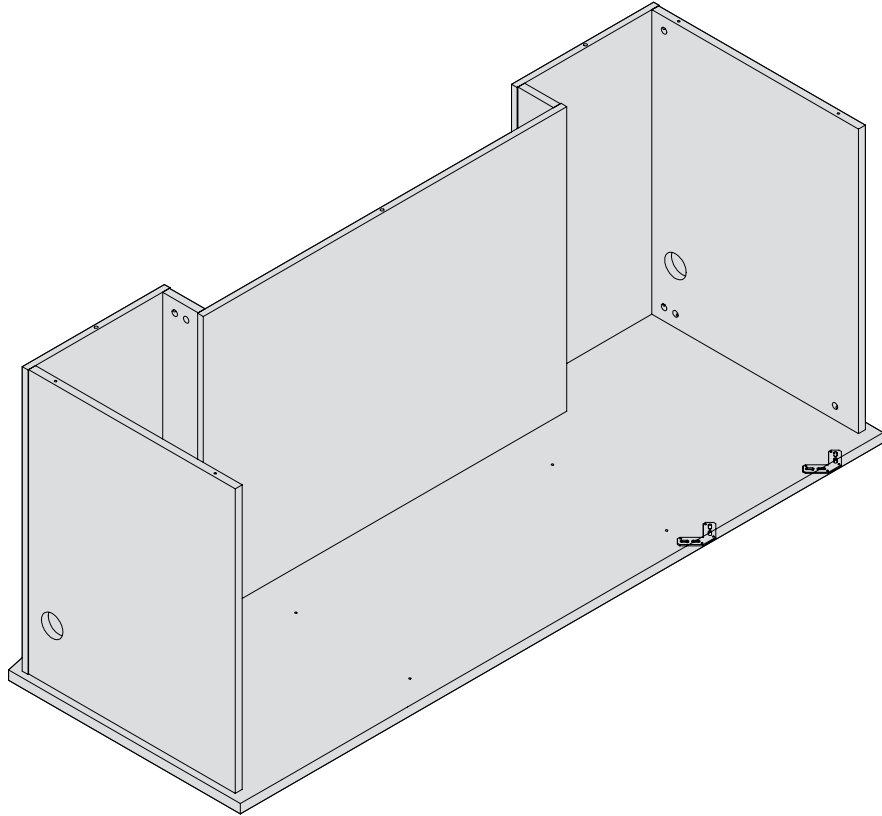

EQ-143

x 2



VR-212

x 4

Code / Código

Qty / Qté / Cant.

Bridge / Pont / Puente

IMPORTANT / IMPORTANTE

Use the parts and hardware remaining.
 Utilisez les pièces et quincailleries restants.
 Utilizar las piezas y quincallas restantes.

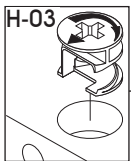
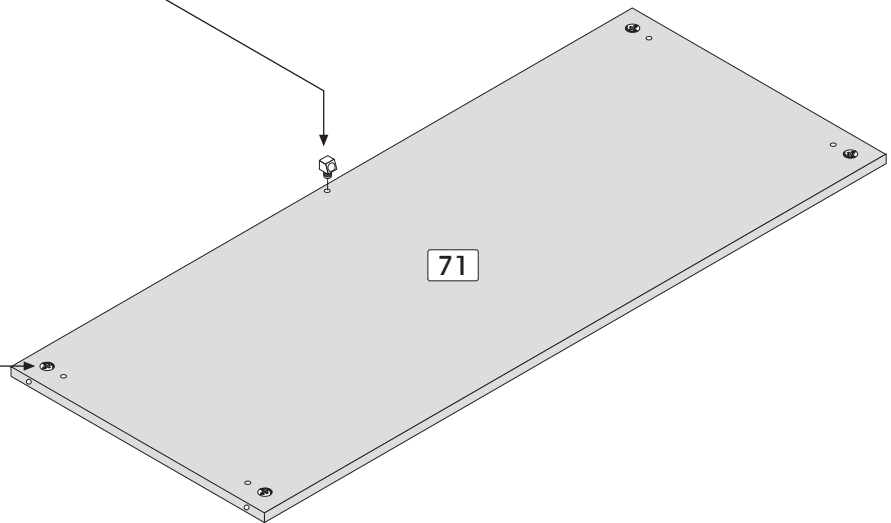
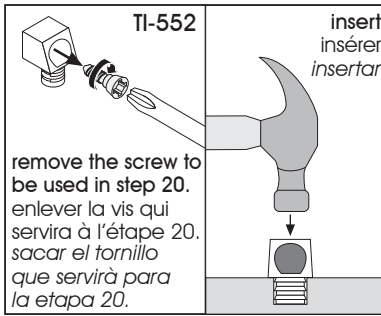
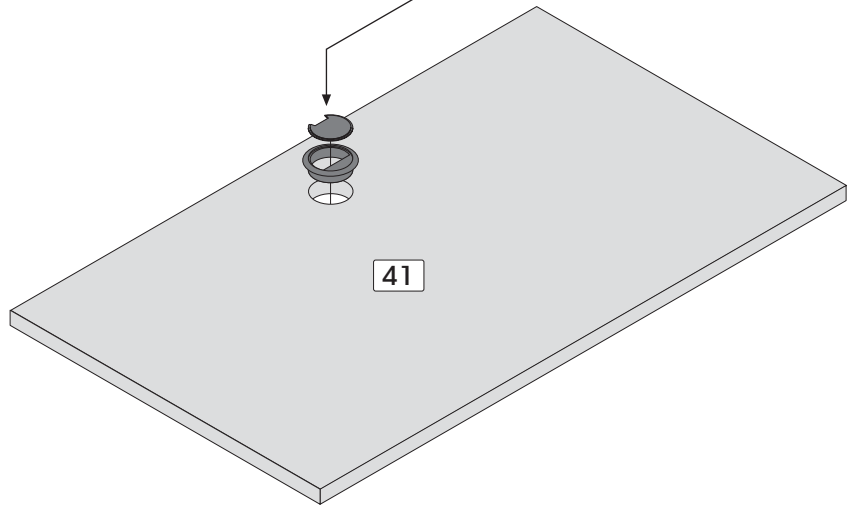
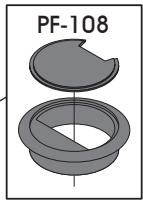

Code / Código	H-03	PF-108	TI-552
Qty / Qté / Cant.	x 4	x 1	x 1

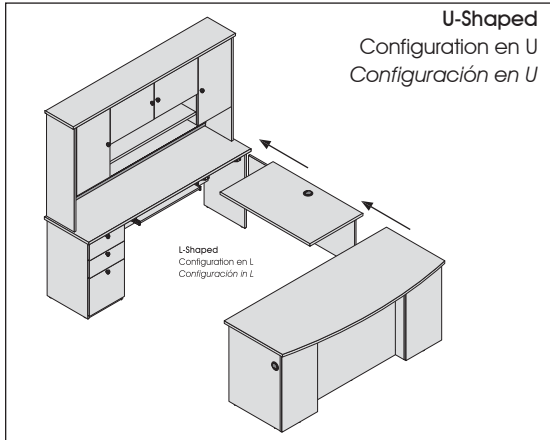

Assembling sequence
Séquence d'assemblage
Secuencia de ensamblaje
Parts / Pièces / Piezas:

30 40 + EQ-143 + 32 42
+ EQ-143 + 41 71



Use the remaining screw from step 16.
Utilisez la vis restante de l'étape 16.
Utilizar el tornillo restante de la etapa 16.

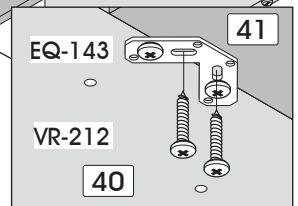
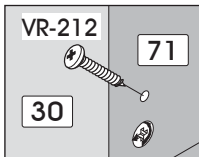
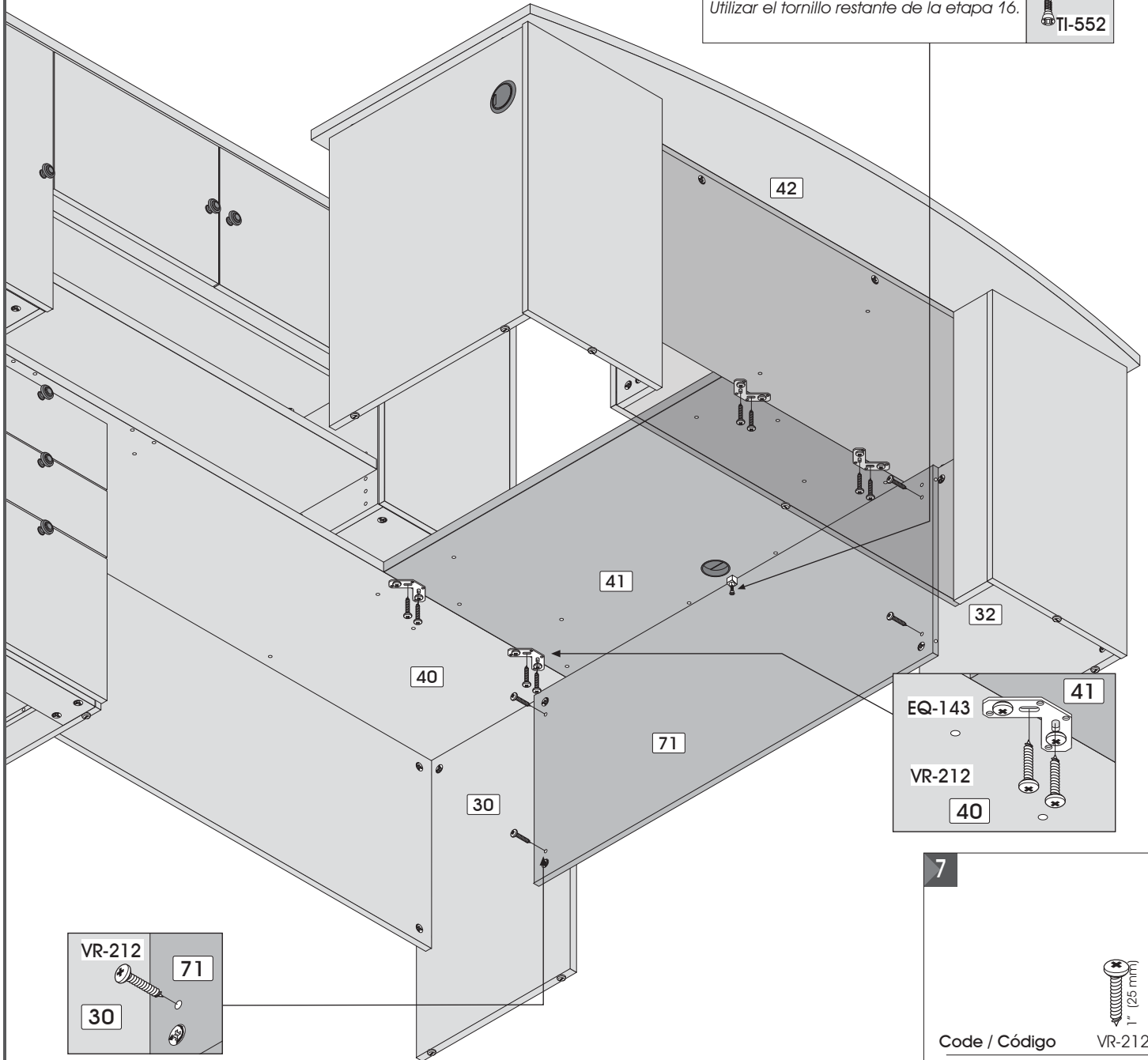
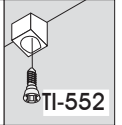

7

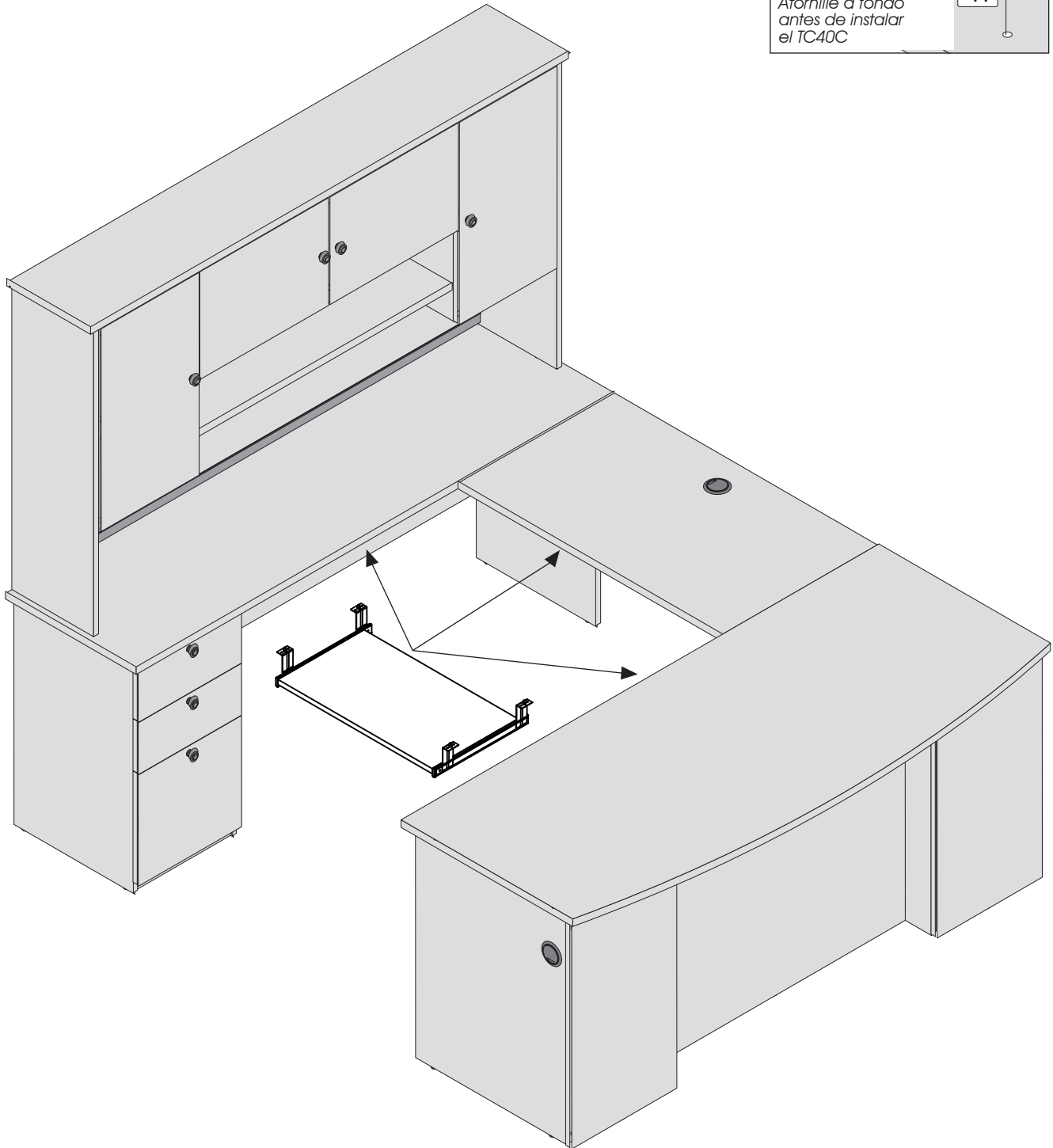
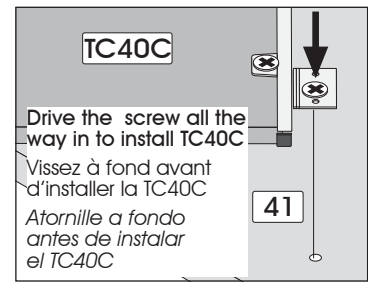

Code / Código VR-212
Qty / Qté / Cant. x 12

IMPORTANT / IMPORTANTE**3 possibilities / 3 possibilités / 3 posibilidades**

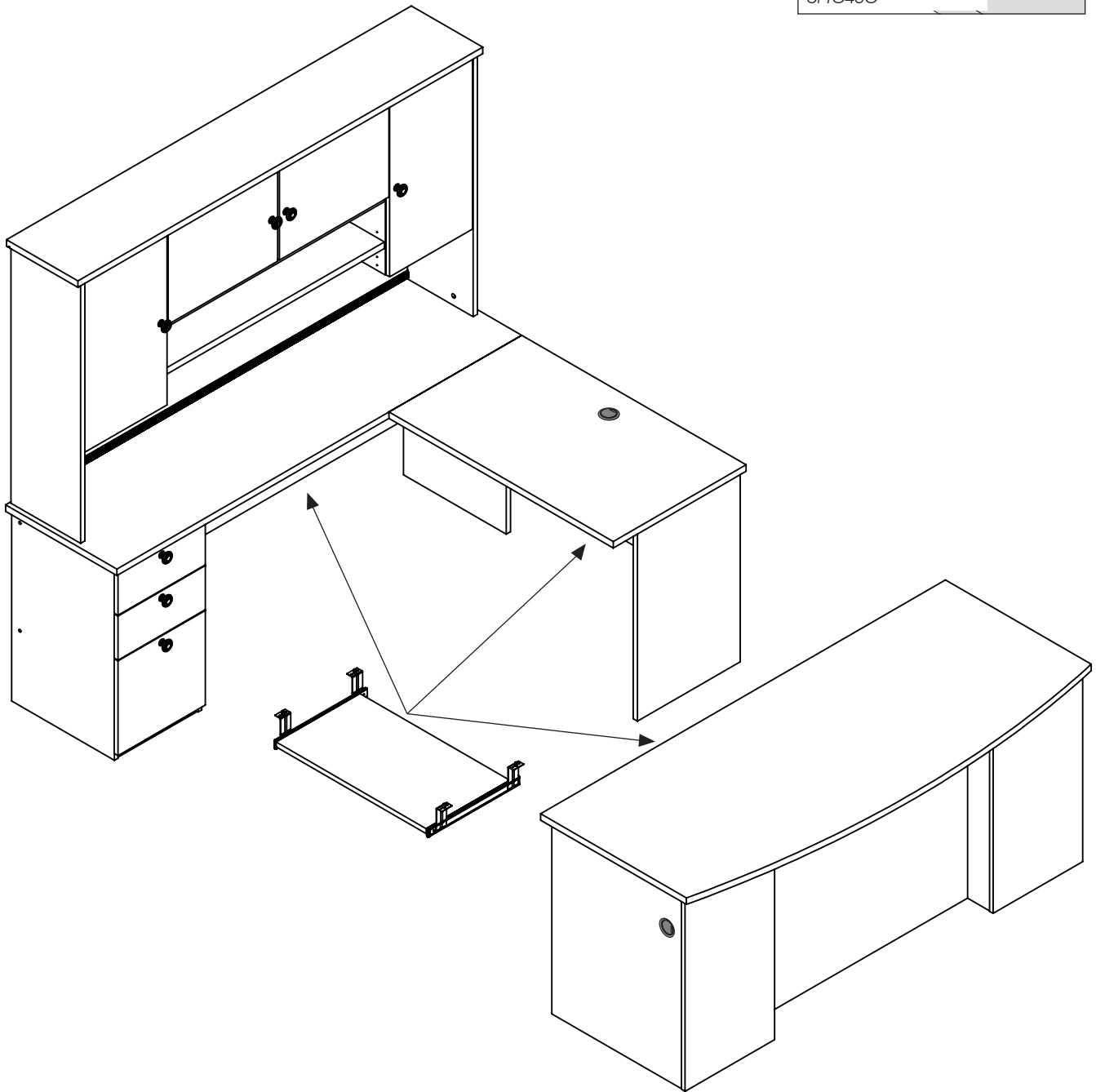
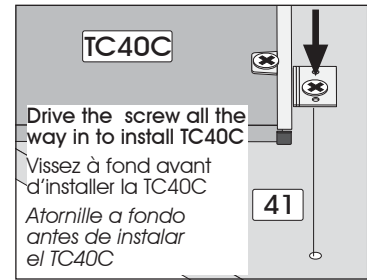
IMPORTANT / IMPORTANTE**3 possibilities / 3 possibilités / 3 posibilidades**



For more information or to discover our new products

Pour toute information ou pour découvrir nos nouveaux produits

Para más información o descubrir nuestros nuevos productos

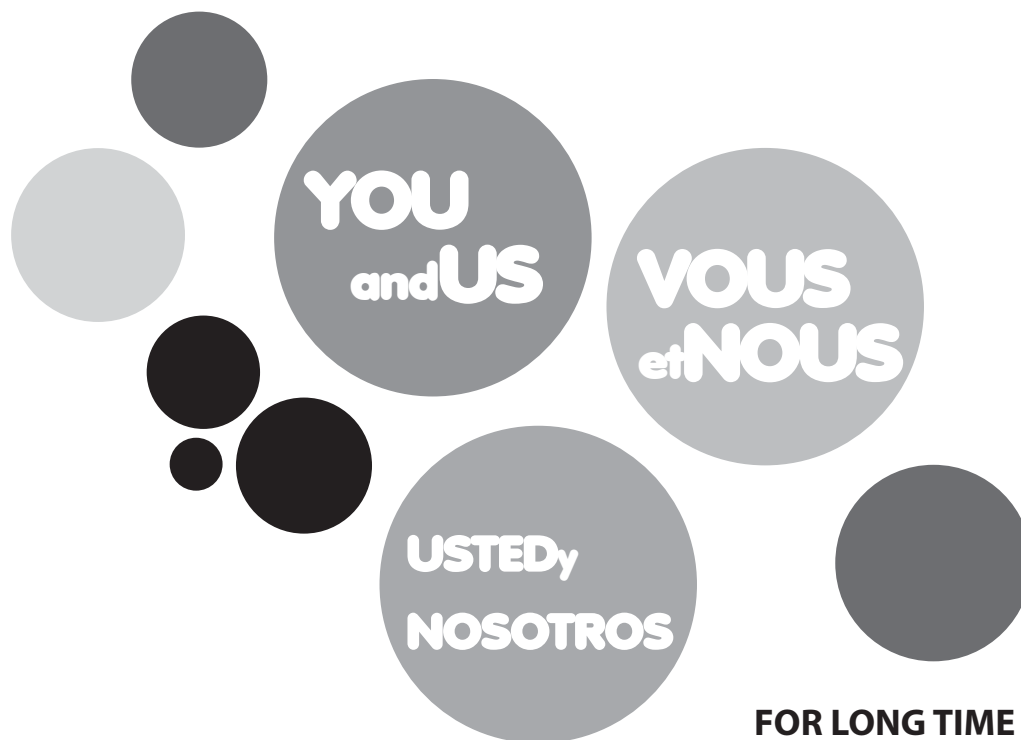

FOR LONG TIME
POUR LONGTEMPS
POR MUCHO TIEMPO

OUR FURNITURE IS GUARANTEED FOR 10 YEARS. NO MATTER THE PROBLEM, OUR CUSTOMER SERVICE IS THERE FOR YOU.

NOS MEUBLES SONT GARANTIS POUR 10 ANS. PEU IMPORTE LE PROBLÈME, N'HÉSITÉZ PAS À COMMUNIQUER AVEC NOTRE SERVICE À LA CLIENTÈLE.

NUESTROS MUEBLES TIENEN UNA GARANTÍA DE 10 AÑOS. NO IMPORTA EL PROBLEMA, COMUNIQUE CON NUESTRO SERVICIO A LA CLIENTELA.

