

# IDECQO

## Assembly Instructions

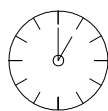
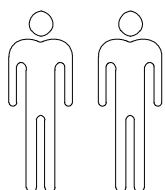
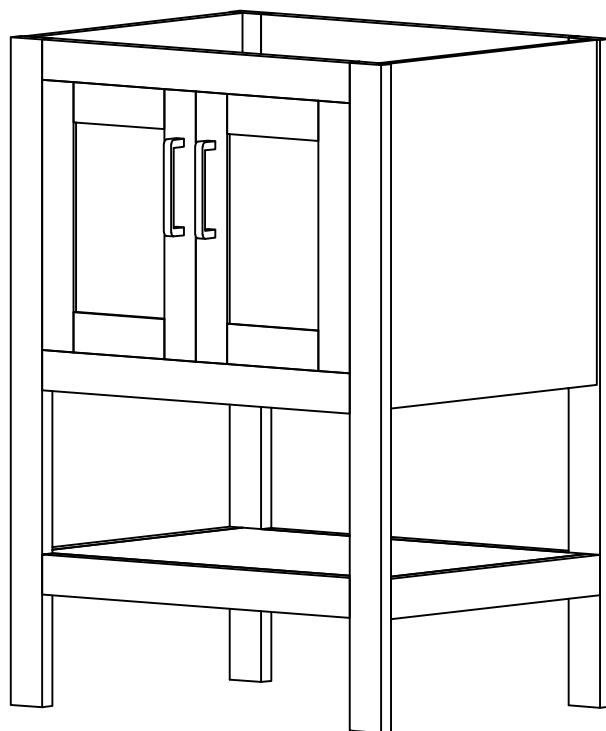

1 Hours

1

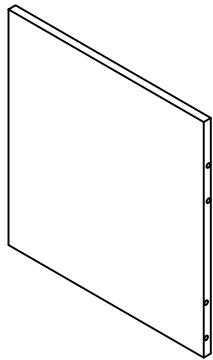

2

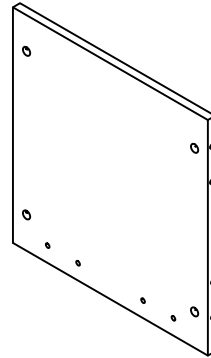

3

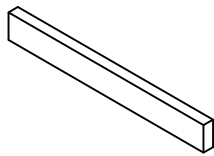

4

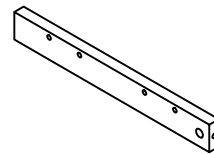

5

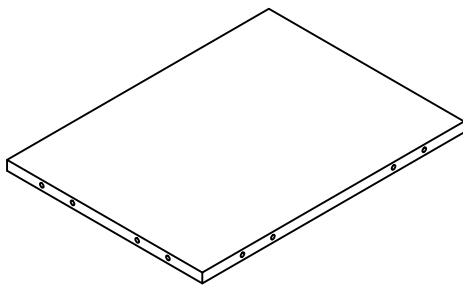

6

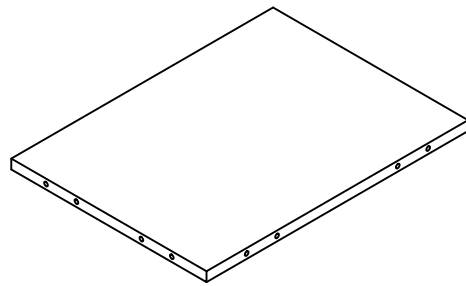



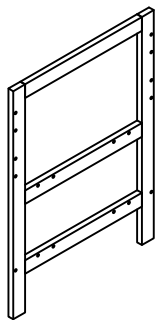



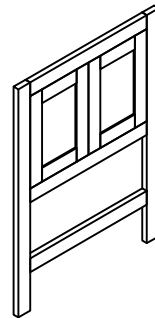

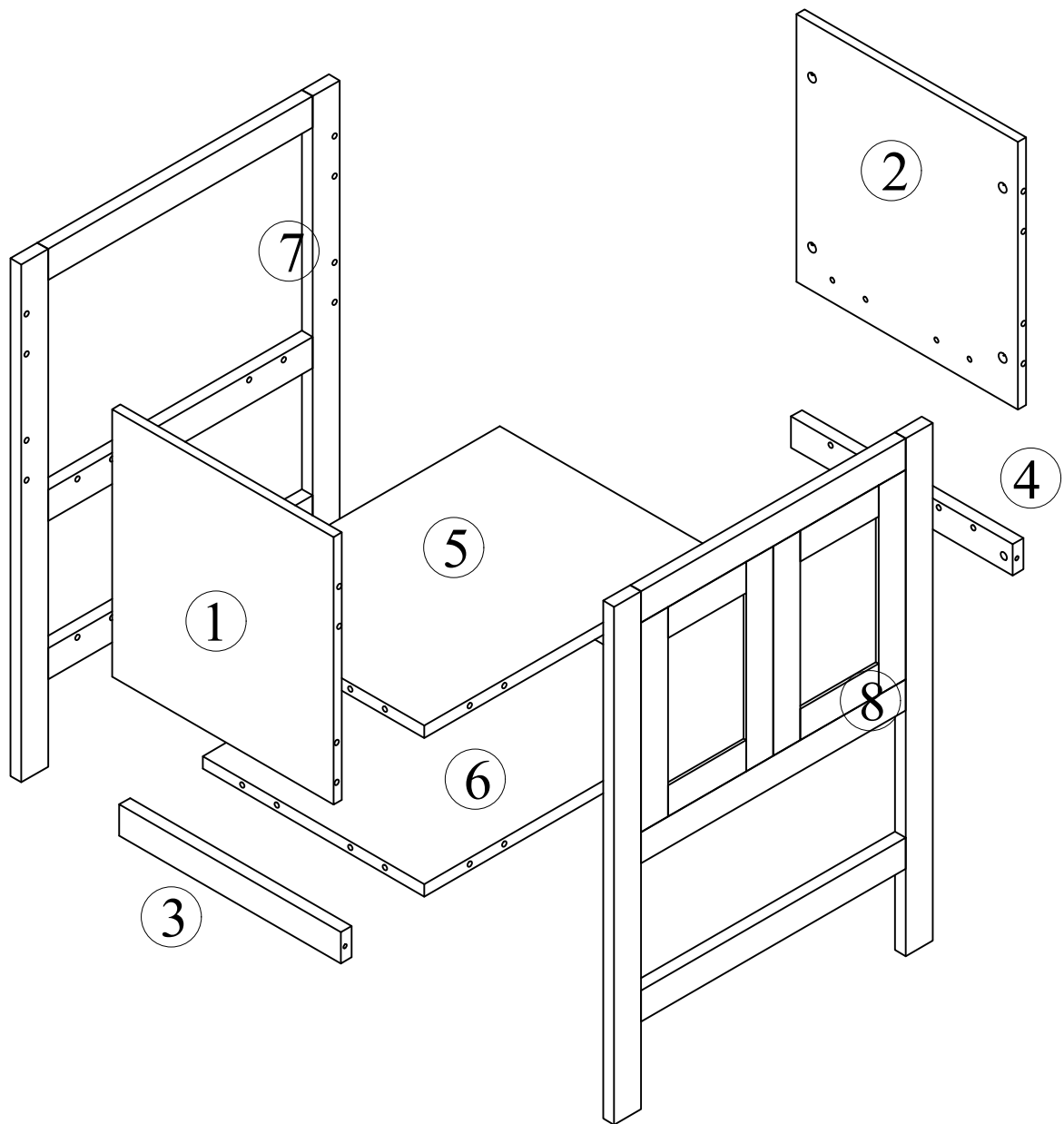

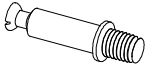

7



8





Part.	Item.	QTY.	
A	M5X45	26	
B		26	
C	Ø8X30	22	
D		2	
E		4	
F		4	
G		1	
H		4	
I		4	
J		2	
K		4	
L		4	
M		4	

**5X45mm bolt installation as below**

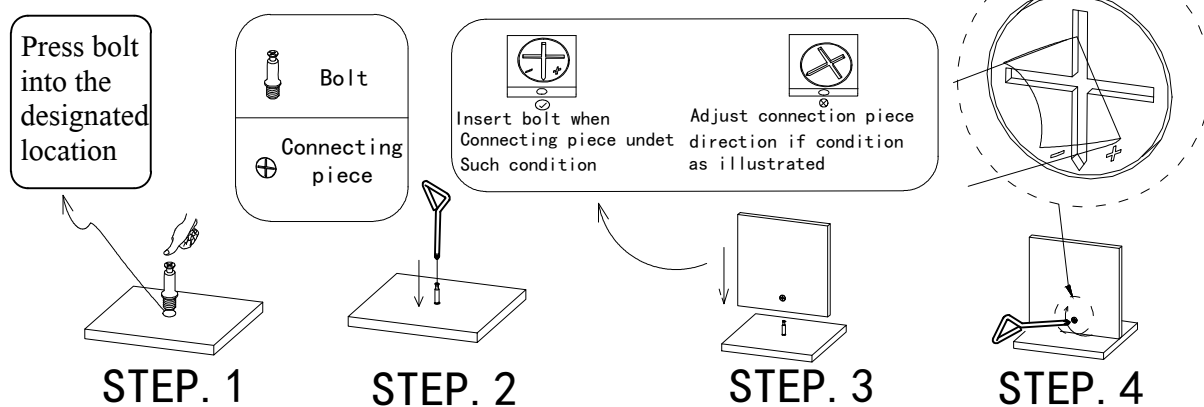

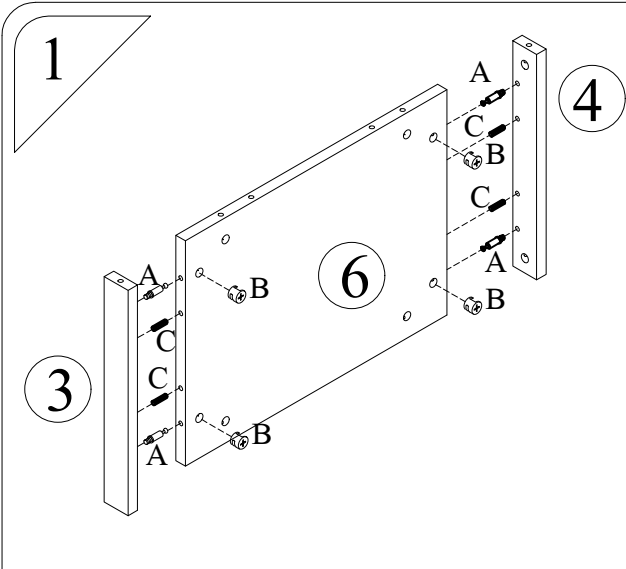

.SCREWS	
A	M5X45 4 PCS
B	4 PCS
C	Ø8X30 4 PCS

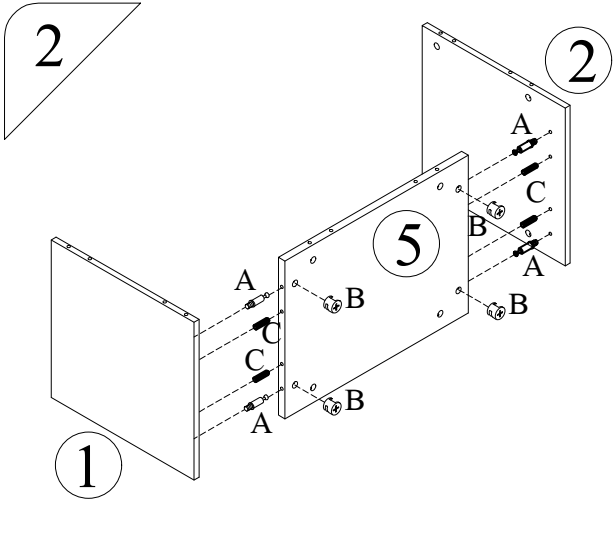
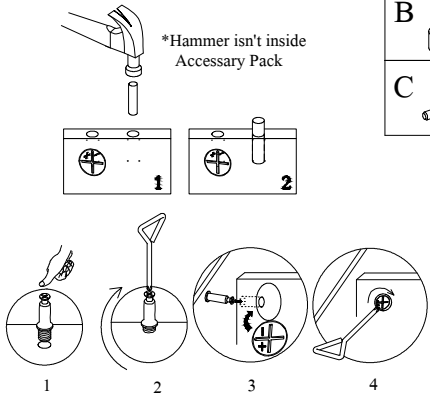

.SCREWS	
A	M5X45 4 PCS
B	4 PCS
C	Ø8X30 4 PCS

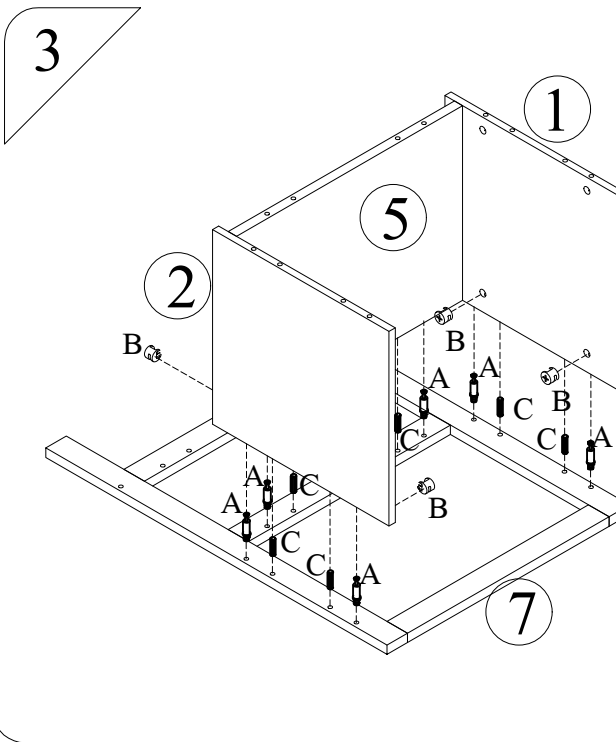
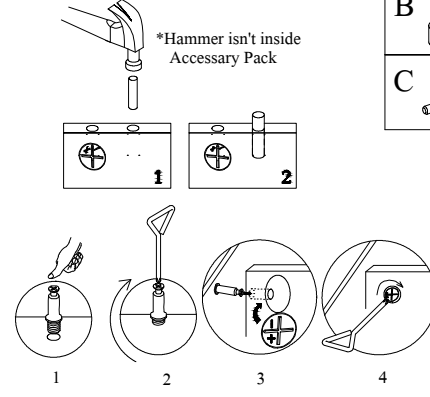

.SCREWS	
A	M5X45 6 PCS
B	6 PCS
C	Ø8X30 6 PCS

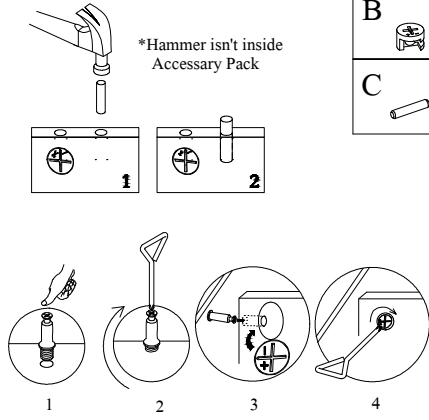

4

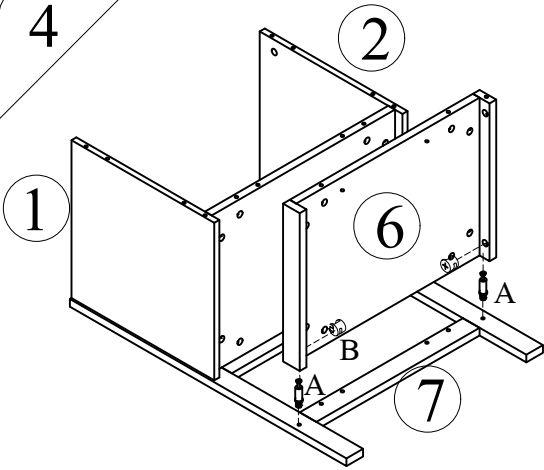

.SCREWS	
A	M5X45 2 PCS
B	2 PCS

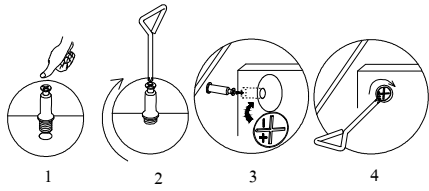

5

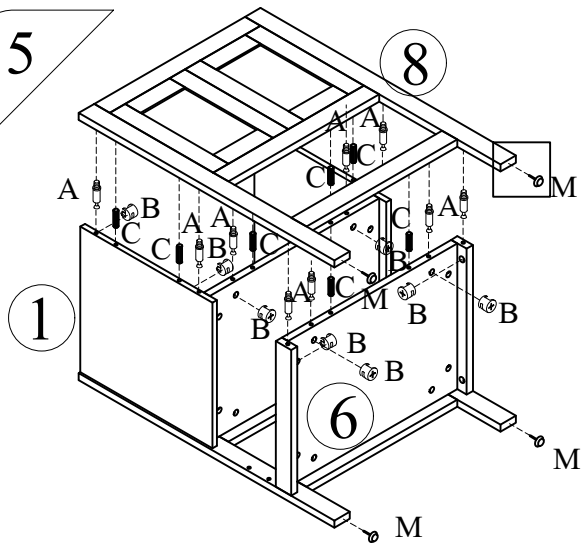

.SCREWS	
A	M5X45 10 PCS
B	10 PCS
C	Ø8X30 8 PCS
M	8 PCS

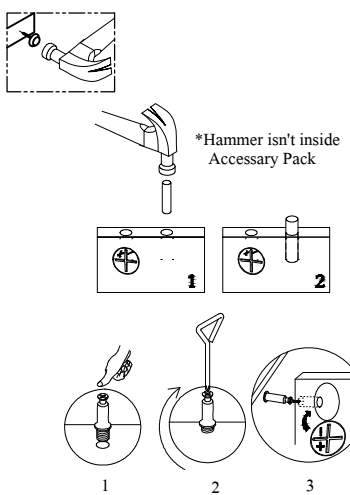

6

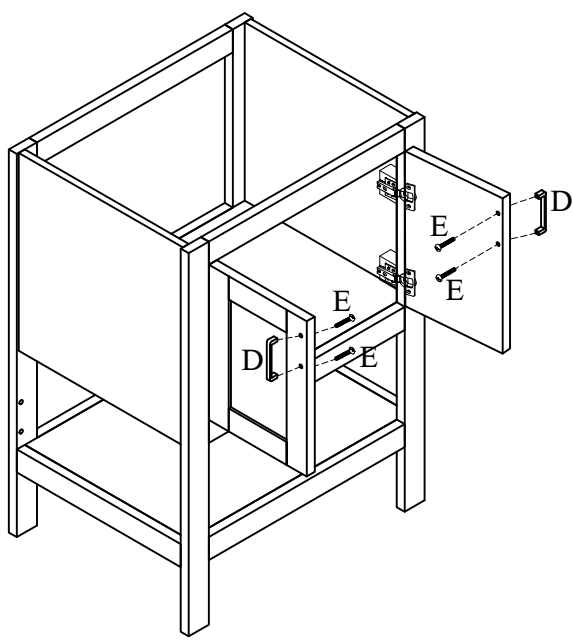

.SCREWS	
D	2 PCS
E	4 PCS

7

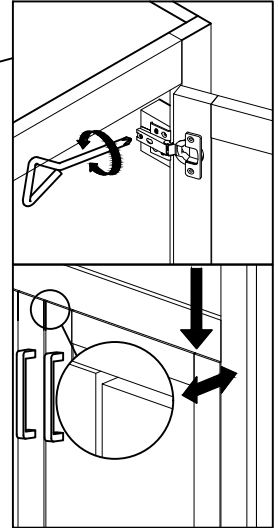
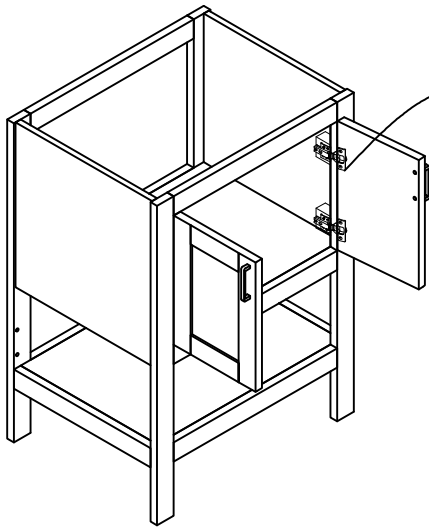

8

