

# EXECUTIVE CHAIR

## OPERATING INSTRUCTIONS

### 1. To Adjust Seat Height:

While seated, lean forward and reach under the right side of the chair to find the handle. Lift the handle and raise your body up slightly to allow the chair to raise to the desired height. To lower the seat, lift the handle while applying more weight downward on the seat. The chair will descend until the handle is released or the chair reaches the bottom position.

### 2. To Operate Tilt Lockout:

While seated, reach under the right side of the chair to find the height adjustment handle. Pull the handle all the way out (away from the gas lift) to allow the chair to tilt backwards. To lock the chair in the upright or vertical position, sit upright and push the handle in towards the gas lift.

### 3. To Adjust Tension on The Tilt Mechanism:

Reach under the front center of the chair, grasp the round knob and turn counter-clockwise to make the tilt mechanism firmer (stiffer). To make the tilt mechanism less firm, turn the knob clockwise until the desired resistance is found.

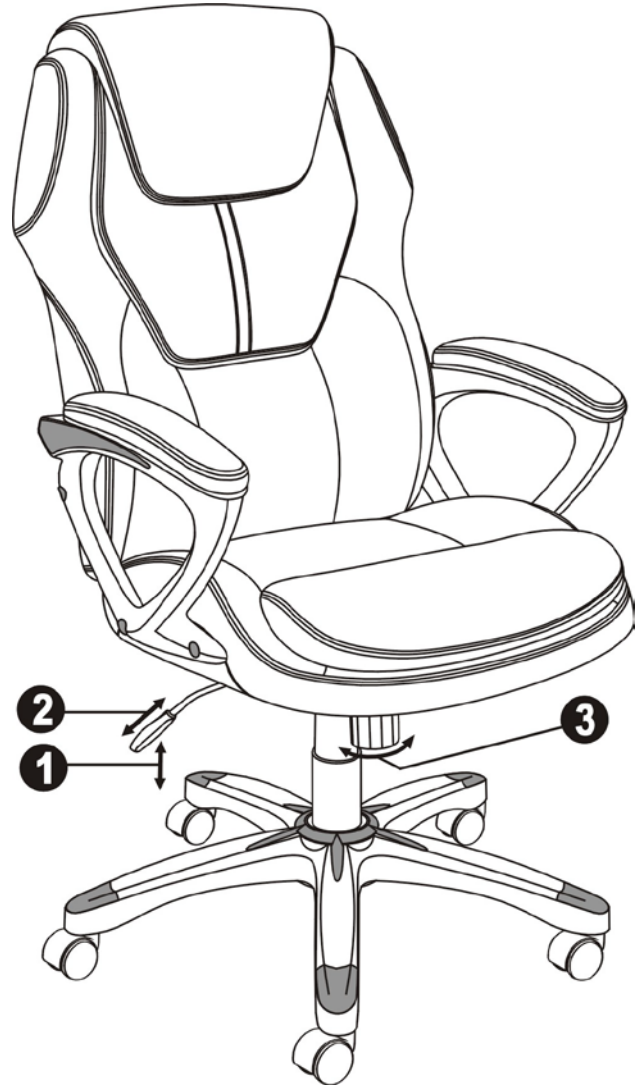

**Model Number: 43673**

# EXECUTIVE CHAIR

## PARTS LIST

Part #	Description	Quantity
1.	Casters	5
2.	5 Star Base	1
3.	Telescoping Cover	1
4.	Gas Lift	1
5.	Seat Plate	1
6A.	Left Arm	1
6B.	Right Arm	1
7.	Seat Cushion	1
8.	Back Cushion	1
9.	1-1/4" Big Screws	2
10.	1" Big Screws	2
11.	1-1/4" Small Screws	8
12.	Black Plastic Caps	2
13.	Black Plastic Caps	2
14.	Black Plastic Caps	4
15.	Allen Keys	2

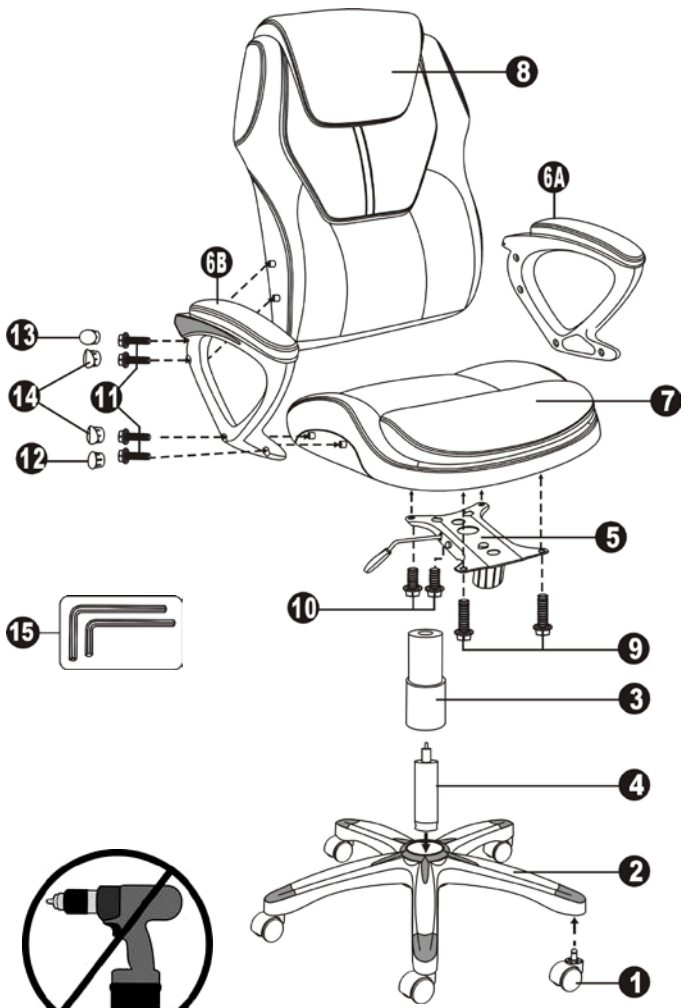

No drill, use tools supplied with chair

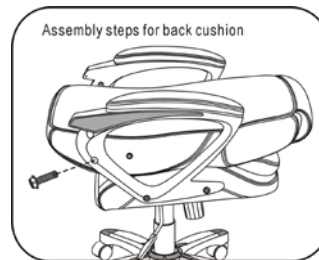

Diagram 1

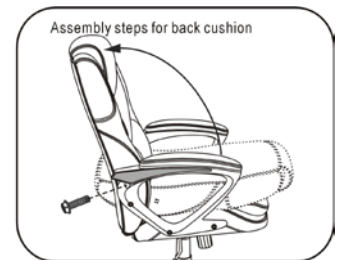

Diagram 2

## ASSEMBLY INSTRUCTIONS

- Remove all parts from carton and separate them into part number groups as indicated in parts list.
- To begin assembly, place 5 star Base (2) upside down and insert Casters (1) into the bottom of the Base (2).
- Turn the Base (2) right side up on the floor and insert Gas Lift (4) into center hole on the Base (2).
- Place Telescoping Cover (3) over the Gas Lift (4) and rest it on the Base (2).
- Attach Seat Plate (5) onto the bottom of Seat Cushion (7) (with front of seat plate facing front of seat cushion) by using 1-1/4" Big Screws (9) for front holes of Seat Plate (5) and 1" Big Screws (10) for rear holes of Seat Plate (5) and **tighten screws.**
- Place the Seat Cushion (7) with the Seat Plate (5) on the top of the Gas Lift (4) and press down until fully engaged.
- Fasten Arms (6A & 6B) onto sides of the Seat Cushion (7) by using 1-1/4" Small Screws (11). **Do not tighten screws completely.**
- Place Back Cushion (8) flat between Arms (6A & 6B), and use 1-1/4" Small Screws (11) to locate lower screw holes on both Arms (6A & 6B) & Back Cushion (8) as shown in Diagram 1. Push the Back Cushion (8) up to a vertical position and attach the Arms (6A & 6B) by using 1-1/4" Small Screws (11) as shown in Diagram 2. **Now tighten all the screws.**
- Place the Black Plastic Caps (12, 13, 14) into arm holes once screws have been tightened.
- Periodically (every 90 days) make sure that the screws are still fully tightened.

**ATTENTION: Make certain all screws are fully tightened before using chair.**

**Model Number: 43673**

**true**  
innovations®