

English

ASSEMBLY INSTRUCTIONS

Thanks for purchasing one of our products.
Please read carefully the assembly instructions before the installation.
Please save this manual for future reference.



Complete video assembly demonstration is available

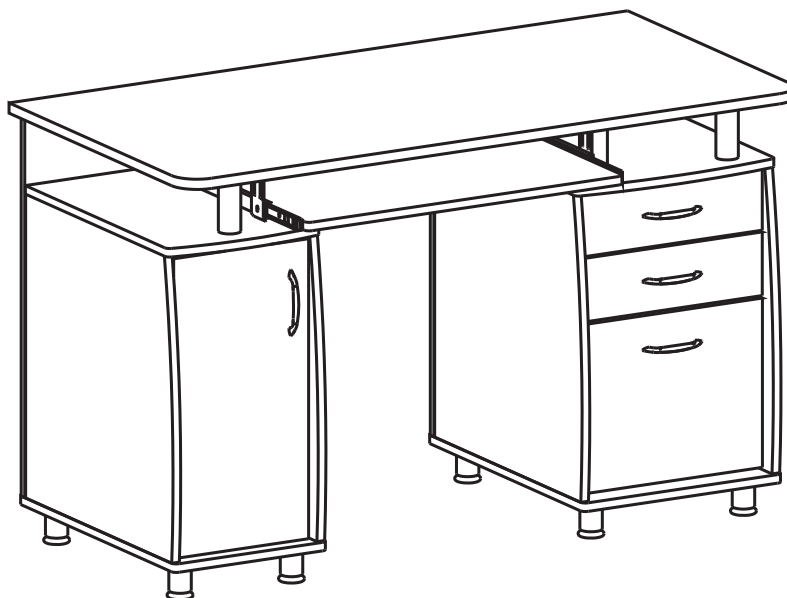

DIMENSIONS

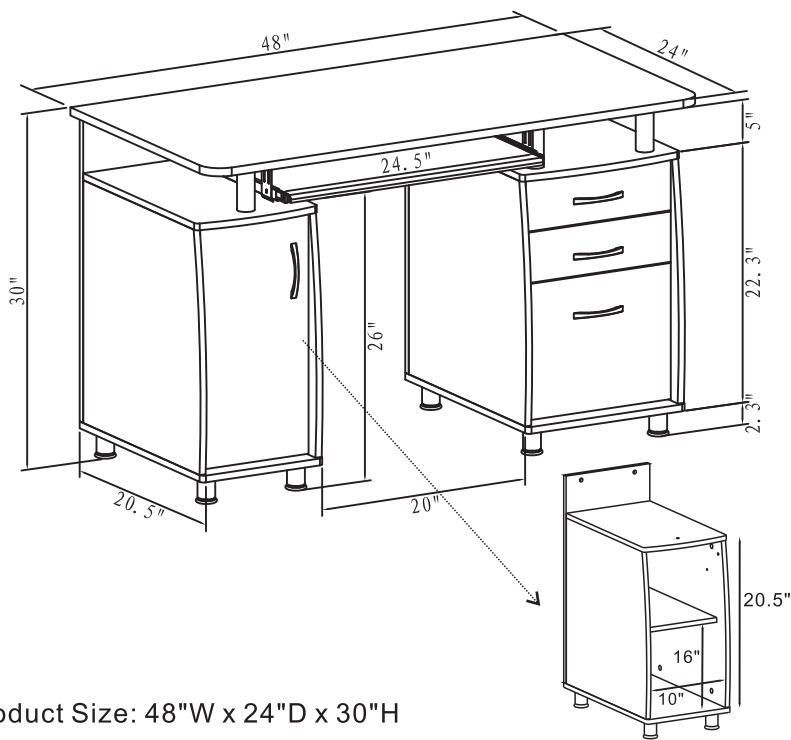

Product Size: 48"W x 24"D x 30"H

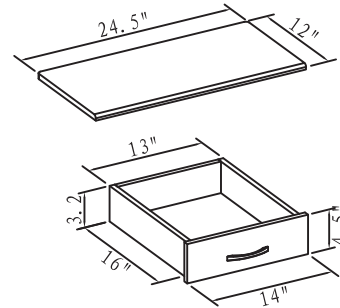

Small Drawers Inside Space: 16"W x 12.5"D x 3.2"H

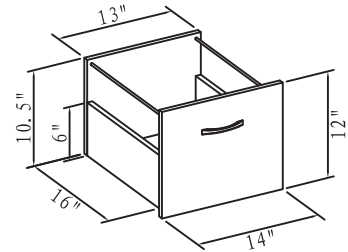

File Drawer Inside Space: 16"W x 12.5"D x 10.5"H



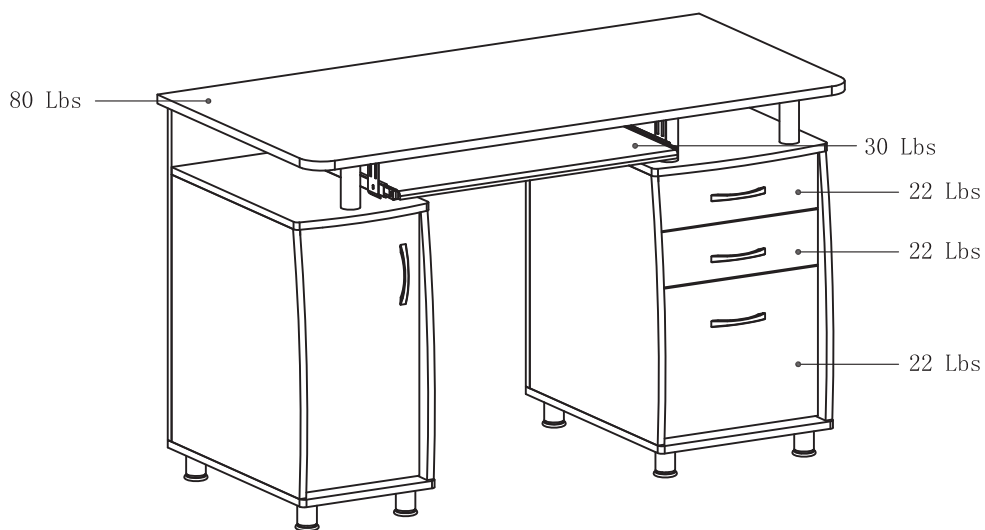



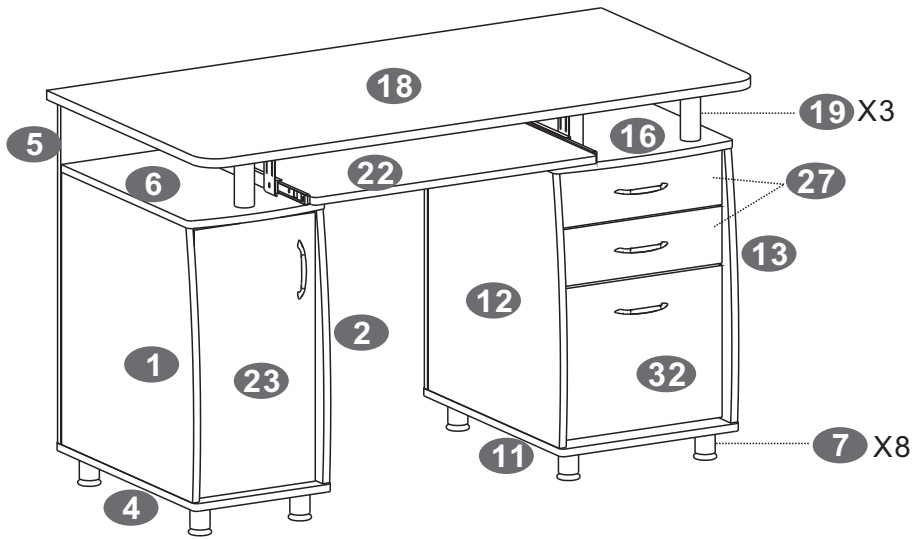

MAXIMUM WEIGHT CAPACITIES

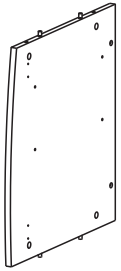
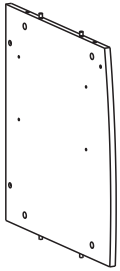

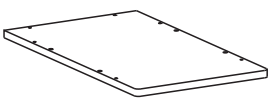
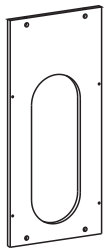
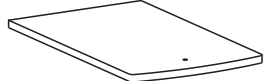

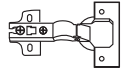

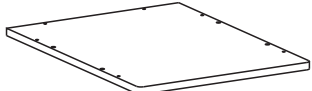
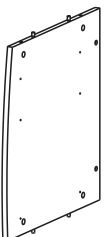

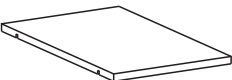

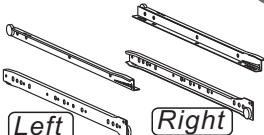
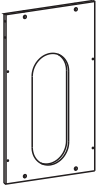
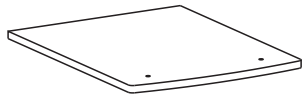
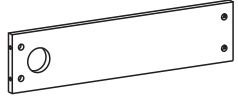
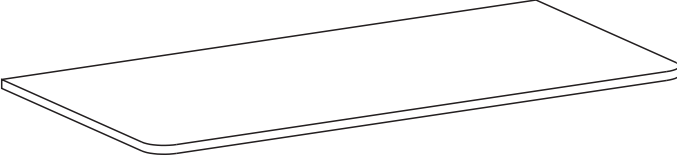

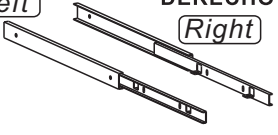

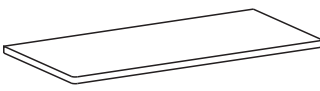
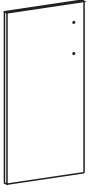
DO NOT exceed this limit
Please use care and good judgement
when placing objects on wood surface

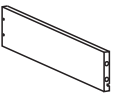

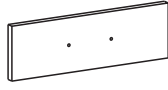

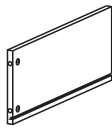
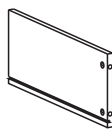
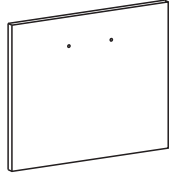
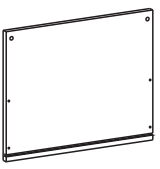
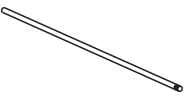

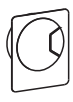

▪ PARTS LIST

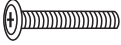



 <p>1</p> <p>▪ CPU Left Panel</p>	 <p>2</p> <p>▪ CPU Right Panel</p>	 <p>3</p> <p>▪ Studs X8</p>	 <p>4</p> <p>▪ CPU Bottom Panel</p>
 <p>5</p> <p>▪ CPU Back Panel</p>	 <p>6</p> <p>▪ CPU Top Panel</p>	 <p>7</p> <p>▪ Base Tubes X8</p>	 <p>8</p> <p>▪ Hinges X2</p>
 <p>9</p> <p>▪ Metal Pin</p>	 <p>11</p> <p>▪ File Cabinet Bottom Panel</p>	 <p>12</p> <p>▪ File Cabinet Left Panel</p>	 <p>13</p> <p>▪ File Cabinet Right Panel</p>
 <p>10</p> <p>▪ Auxiliary Panel</p>			

<p>X3 SET 14</p>  <p>▪ Drawer Sliders</p>	<p>15</p>  <p>▪ File Cabinet Back Panel</p>	<p>16</p>  <p>▪ File Cabinet Top Panel</p>	<p>17</p>  <p>▪ Central Panel</p>
<p>18</p>  <p>▪ Main Panel</p>		<p>19</p>  <p>X3 ▪ Supporting Tubes for Main Panel</p>	<p>20</p> <p>IZQUIERDO Left DERECHO Right</p>  <p>▪ Keyboard Slider</p>
<p>21</p>  <p>X4 ▪ Slider's Base</p>	<p>22</p>  <p>▪ Keyboard Panel</p>	<p>23</p>  <p>▪ CPU Door</p>	<p>24</p>  <p>X4 ▪ Handles</p>
<p>25</p>  <p>X2 ▪ Small Drawer Left Panel</p>	<p>26</p>  <p>X2 ▪ Small Drawer Right Panel</p>	<p>27</p>  <p>X2 ▪ Small Drawer Front Panel</p>	<p>28</p>  <p>X3 ▪ Drawer Bottom Panel</p>
<p>29</p>  <p>X2 ▪ Small Drawer Back Panel</p>	<p>30</p>  <p>▪ Bottom Drawer Left Panel</p>	<p>31</p>  <p>▪ Bottom Drawer Right Panel</p>	<p>32</p>  <p>▪ Bottom Drawer Front Panel</p>
<p>33</p>  <p>▪ Bottom Drawer Back Panel</p>	<p>34</p>  <p>X2 ▪ Hanging Files Tubes</p>	<p>35</p>  <p>X4 ▪ Metal Pin</p>	<p>36</p>  <p>▪ Grommet</p>

▪ SCREWS

PART	QTY.	ITEM	
A	3	6X35 MM	
B	12	4X35 MM	
C	24	3X15 MM	
D	8	4X20 MM	
E	16	6X40 MM	
F	48	4X14 MM	
G	8	4X16 MM	
H	4	6X12 MM	

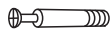
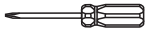
PART	QTY.	ITEM	
I	4	4X4 MM	
J	3	Φ40 MM	
K	32	6X25 MM	
	1		

HOW TO ASSEMBLE USING BOLTS AND CAM LOCKS:

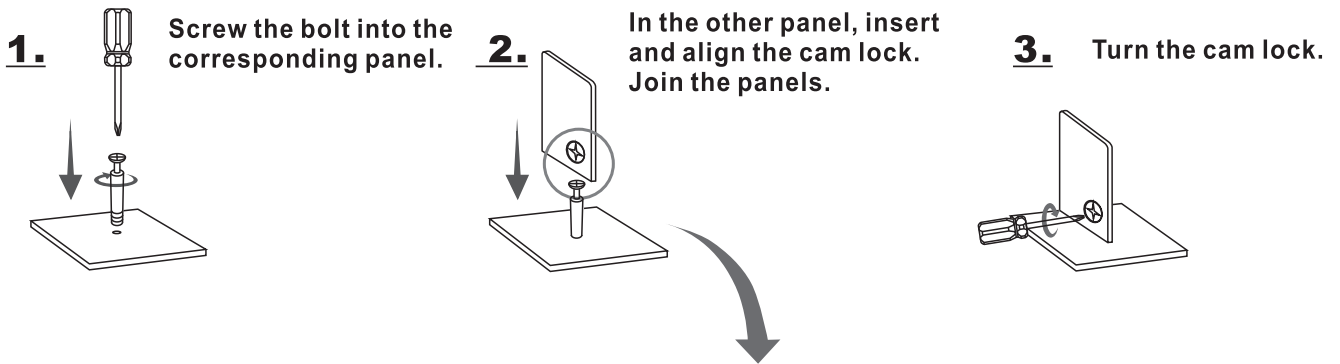

If the panel already comes with the cam lock inserted, make sure is aligned:

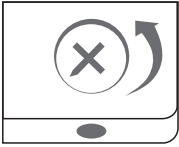

MISALIGNED:
TURN CAM LOCK
TO POINT TOWARDS
THE HOLE

X

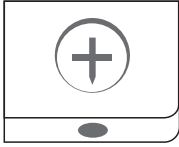

CORRECT

✓

GENERAL ASSEMBLY TIPS AND TROUBLESHOOTING DURING ASSEMBLY:

- *Before you start assembling, make sure you have all the parts and necessary hardware by doing a quick inventory.
- *Follow the assembly instructions step by step, and do not skip any unless advised to do so by Customer Service.
- *On each step, and to avoid misalignments, always leave screws loose, and do not tighten them until all are in place.
- *In wood panels, the laminate might be covering the holes.
 If there are no visible holes: Pass the tip of your finger around the area where the hole should be, and press against the surface to feel the indentation.
 If the hole looks too small for the screw or bolt: carefully perforate the laminate with the tip of a pen.

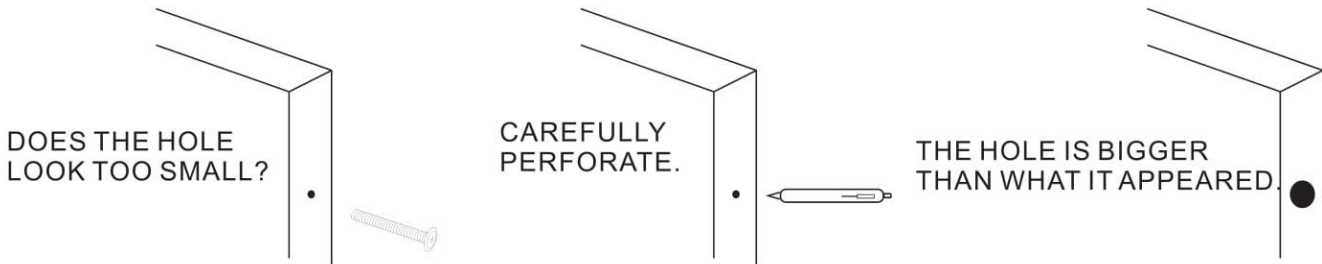

- *In wood panels, some might have inserts that look like screws. Those inserts are either nuts or cam locks. Make sure they are aligned to receive the screws or bolts.

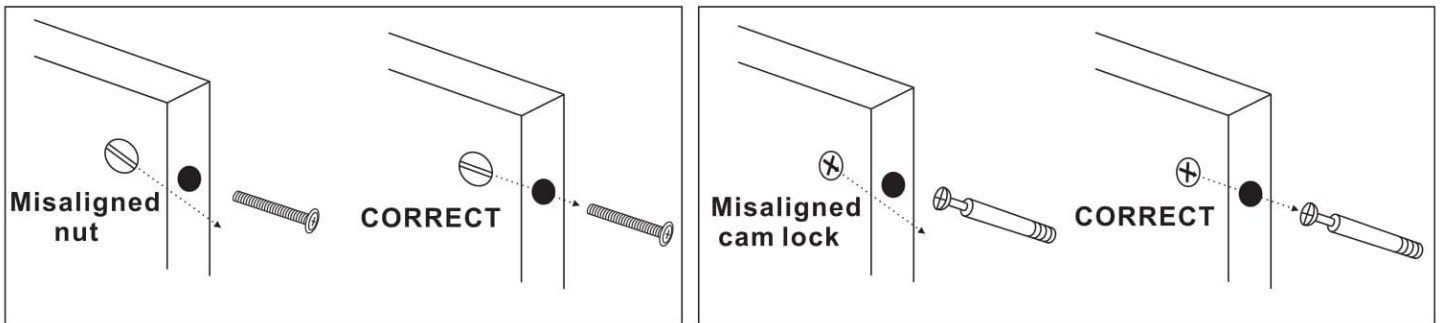

- *Make sure to use the correct screws or bolts, and do not overtighten them. Using wrong screws or overtightening them might cause damage to the parts, and such damage is not covered by the product's warranty.

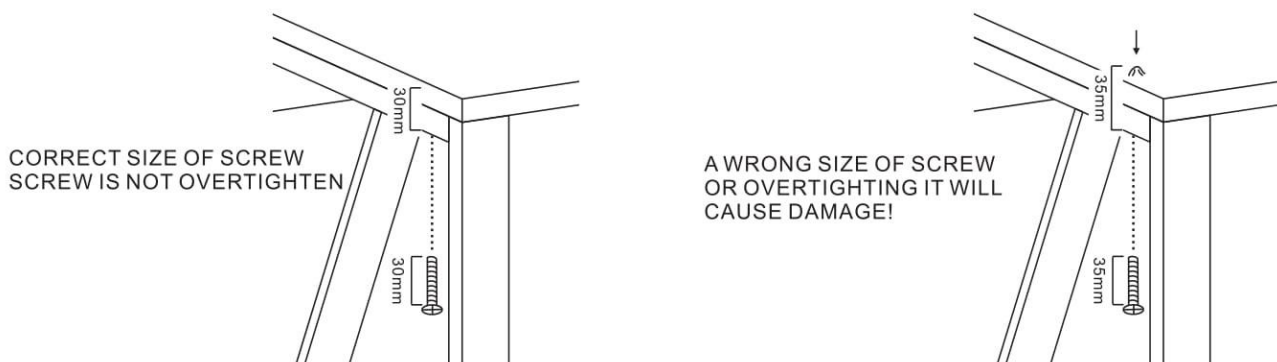

▪ ASSEMBLY STEPS:

1

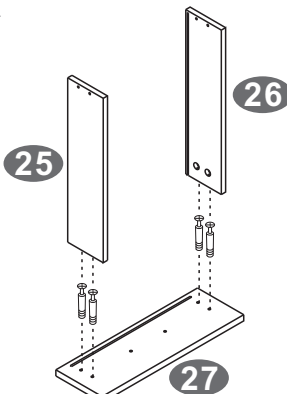

▪ First screw bolts K to the Front Panel (27), then assemble the Small Drawer Left & Right Panels (25 & 26) as explained in page 5.

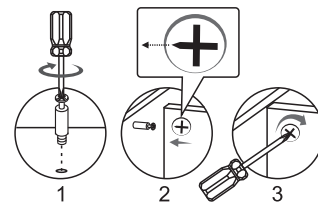

▪ SCREWS

K 6X25 MM 4PCS



2

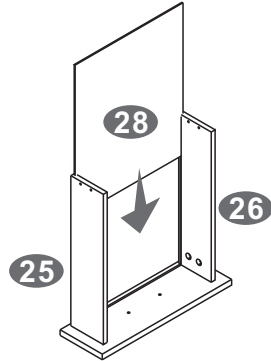

▪ Slide in the Drawer Bottom Panel (28).

3

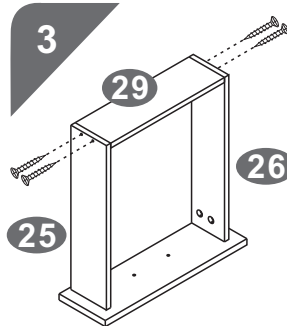

▪ Use screws B to assemble the Small Drawer Back Panel (29) to the Small Drawer Left & Right Panels (25 & 26).

▪ SCREWS

B 4X35 MM 4PCS



4

▪ Grab 2 sets of the Drawer Sliders (14) and separate the flat ones from the “L” shaped ones. Place the drawer upside-down as shown and use screws C to assemble the “L” shaped Sliders to the Small Drawer Left & Right Panels (25 & 26) as shown.

IMPORTANT: REFER TO THE DRAWINGS FOR THE CORRECT POSITION OF THE SLIDERS. If they get installed incorrectly, the drawers will raise 1" with a gap at the bottom and the top drawer will not close!

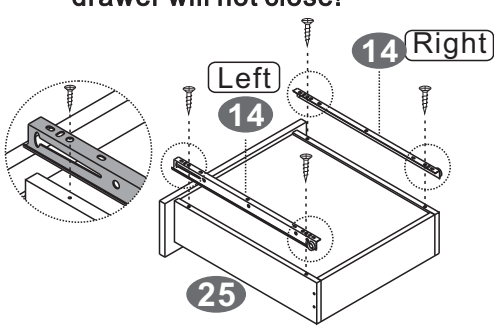
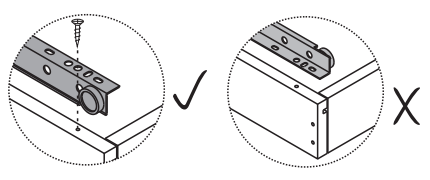
▪ SCREWS

C 3X15 MM 4PCS



5



▪ Use screws D to fix the Handles (24) to the Small Drawer Front Panel (27).

REPEAT STEPS 1 THRU 5 FOR THE SECOND SMALL DRAWER

▪ SCREWS

D 4X20 MM 2PCS



6

▪ First screw bolts K to the Bottom Drawer Front Panel (32), then assemble the Bottom Drawer Left & Right Panels (30 & 31) as explained in page 5.

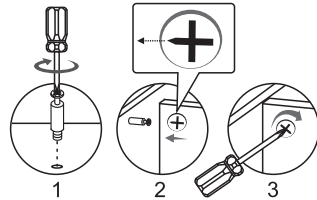
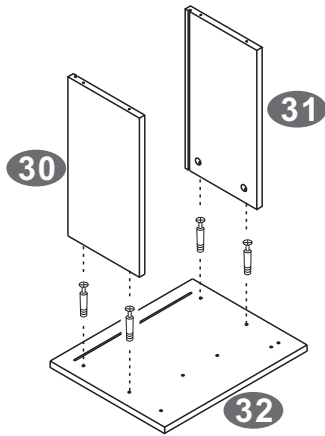

▪ SCREWS

K 6X25 MM

4PCS



7

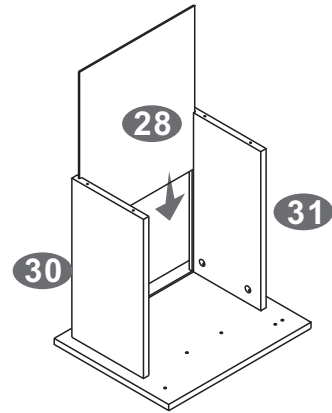

▪ Slide in the Drawer Bottom Panel (28).

8

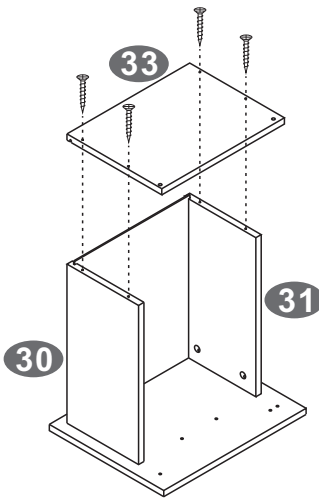

▪ Use screws B to assemble the Bottom Drawer Back Panel (33) to the Bottom Drawer Left & Right Panels (30 & 31).

▪ SCREWS

B 4X35 MM

4PCS



9

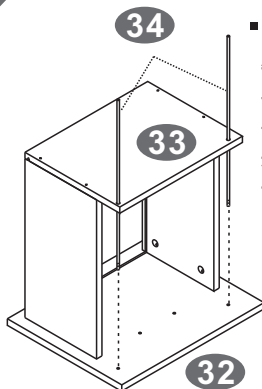

▪ Insert the Hanging Files Tubes (34) thru the Bottom Drawer Back Panel (33) **AND SLOWLY AND CAREFULLY** screw into the Bottom Drawer Front Panel (32). **IMPORTANT: OVERTIGHTENING THE TUBES WILL DAMAGE THE FRONT PANEL BY MAKING A BUMP OR EVEN PERFORATING THE PANEL ON THE OTHER SIDE, AND SUCH DAMAGE IS NOT COVERED BY THE PRODUCT'S WARRANTY!**

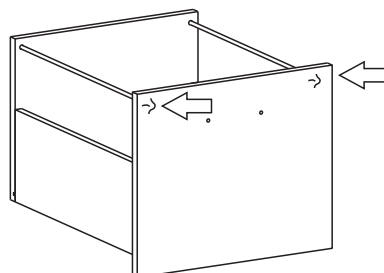

OVERTIGHTENING WILL DAMAGE THE FRONT PANEL!

10

▪ Grab the other set of the Drawer Sliders (14) and separate the flat ones from the "L" shaped ones. Place the drawer upside-down as shown and use screws C to assemble the "L" shaped Sliders to the Bottom Drawer Left & Right Panels (30 & 31) as shown.
IMPORTANT: REFER TO THE DRAWINGS FOR THE CORRECT POSITION OF THE SLIDERS. If they get installed incorrectly, the drawers will raise 1" with a gap at the bottom and the top drawer will not close!

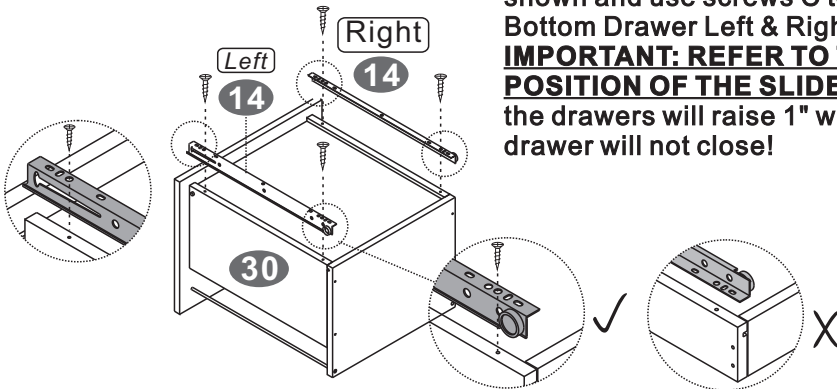

▪ SCREWS

C 3X15 MM
 4PCS



11

▪ Use screws D to fix the Handle (24) to the Bottom Drawer Front Panel (32).

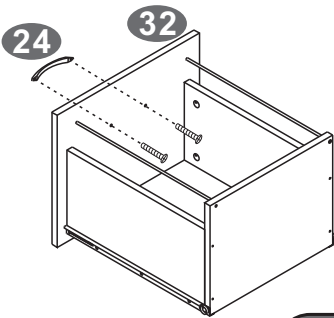

▪ SCREWS

D 4X20 MM
 2PCS



12

▪ Use screws F to assemble the Base Tubes (7) to the CPU Bottom Panel (4).

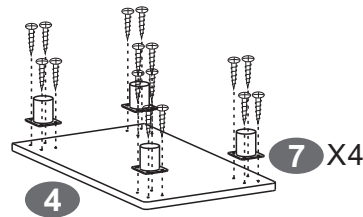

▪ SCREWS

F 4X14 MM
 16PCS



13

▪ Insert the Studs (3) into the Base Tubes (7) and tighten them well at the same level.

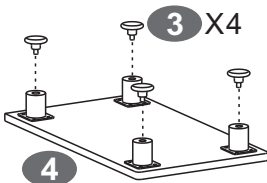

14

▪ First screw bolts K to the CPU Back Panel (5), then assemble the CPU Left & Right Panels (1 & 2) as explained in page 5. Please note: The CURVED side of the panels are the FRONT of the cabinet, and the panels are WIDER at the bottom than at the top. Screw the Metal Pin (9) to the CPU Right Panel (2).

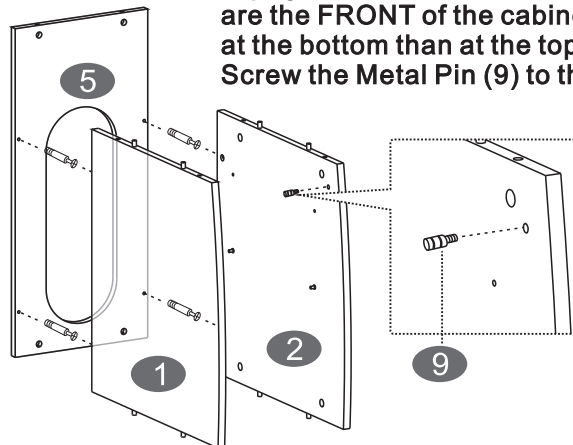

▪ SCREWS

K 6X25 MM
 4PCS

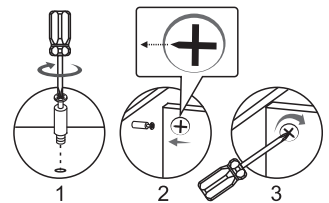

15

K (For the 2 back holes)

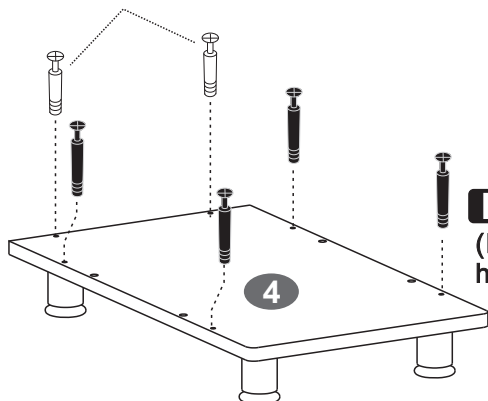

▪ Screw bolts K to the 2 back holes of the CPU Bottom Panel (4), and screw bolts E to the 1st and 4th holes on the side (the 2nd and 3rd holes are for receiving the wooden pins of panels 1 & 2).

E X4
(For the 1st and 4th holes on the sides)

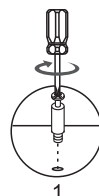

▪ SCREWS

E 6X40 MM

4PCS

K 6X25 MM

2PCS

16

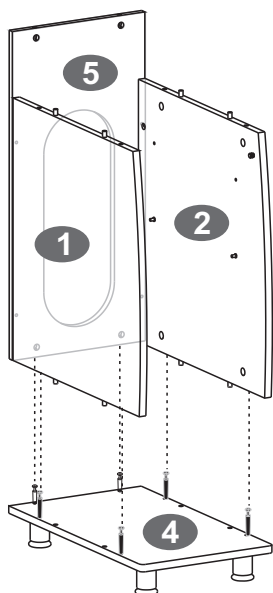

▪ Assemble the parts (1,2 & 5) that you assembled in step 14 to the CPU Bottom Panel (4) as explained in page 5.

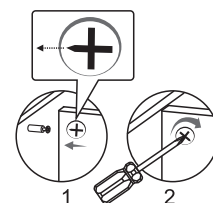

17

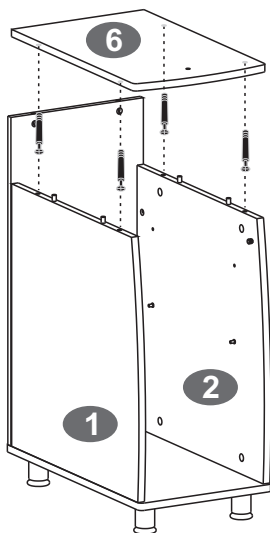

▪ First screw bolts E to the CPU Top Panel (6), then assemble this panel to Left & Right Panels (1 & 2) as explained in page 5.

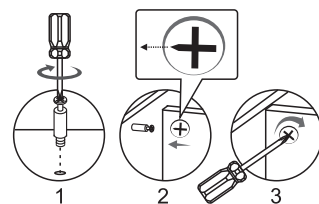

▪ SCREWS

E 6X40 MM

4PCS

18

▪ Insert the Metal Pins (35) into the holes of the CPU Left & Right Panels (1 & 2) at your desired height, then place the Auxiliary Panel (10) over the pins.

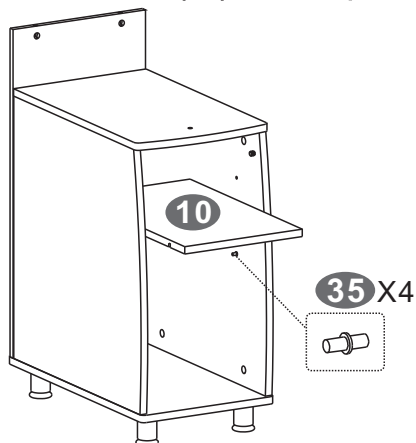

19

▪ Use screws F to assemble the Base Tubes (7) to the File Cabinet Bottom Panel (11).

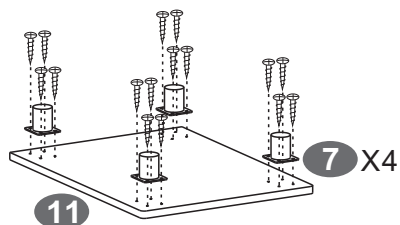

▪ SCREWS

F 4X14 MM

16PCS



20

▪ Insert the Studs (3) into the Base Tubes (7) and tighten them well at the same level.

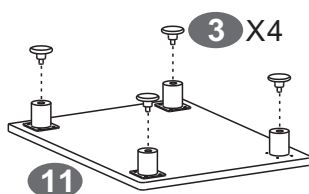

21

▪ Get 2 sets of the Flat Sliders (14) and use screws C to assemble them to the top and middle of the File Cabinet Left & Right Panels (12 & 13) as shown. Please note: The CURVED side of the panels are the FRONT of the cabinet, and the panels are WIDER at the bottom than at the top. The wheel on the sliders go facing to the FRONT and the screw goes on the hole after the wheel as shown.

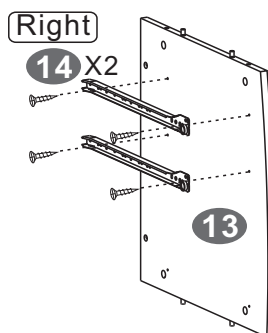
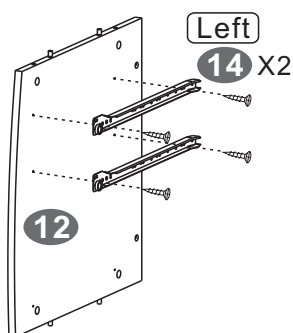
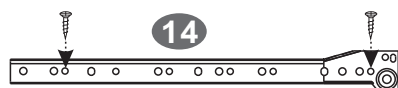

▪ SCREWS

C 3X15 MM

8PCS



22

▪ First screw bolts K to the File Cabinet Back Panel (15), then assemble this panel to the File Cabinet Left & Right Panels (12 & 13) as explained in page 5.

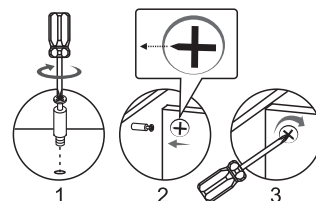
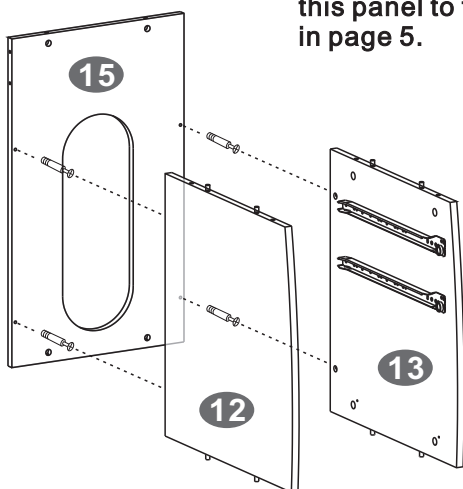

▪ SCREWS

K 6X25 MM

4PCS



23

K (For the 2 back holes)

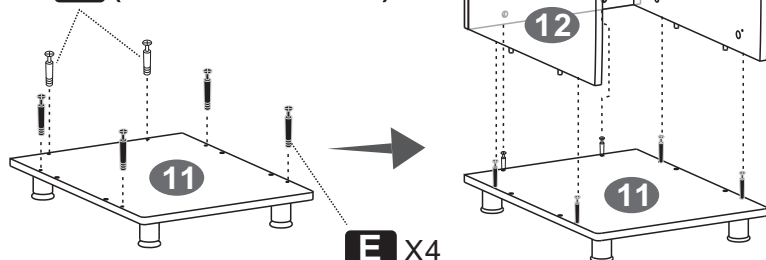

E X4
(For the 1st and 4th holes on the sides)

▪ Screw bolts K to the 2 back holes of the File Cabinet Bottom Panel (11), and screw bolts E to the 1st and 4th holes on the side (the 2nd and 3rd holes are for receiving the wooden pins of panels 12 & 13). Then assemble the parts (12, 13 & 15) to the File Cabinet Bottom Panel (11), as explained in page 5.

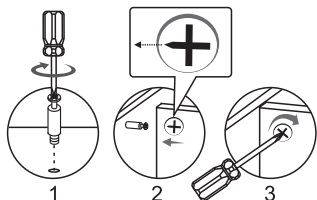

▪ SCREWS

E 6X40 MM

4PCS

K 6X25 MM

2PCS



24

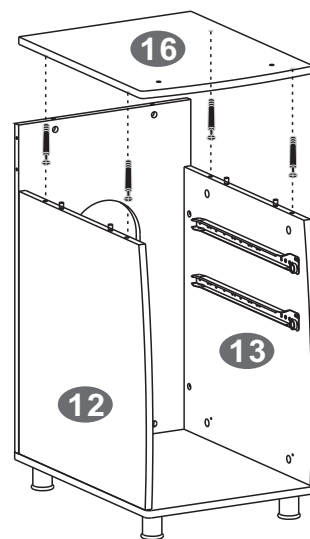

▪ First screw bolts E to the File Cabinet Top Panel (16), then assemble this panel to Left & Right Panels (12 & 13) as explained in page 5.

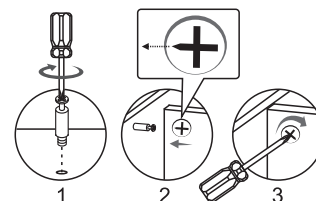

▪ SCREWS

E 6X40 MM

4PCS



25

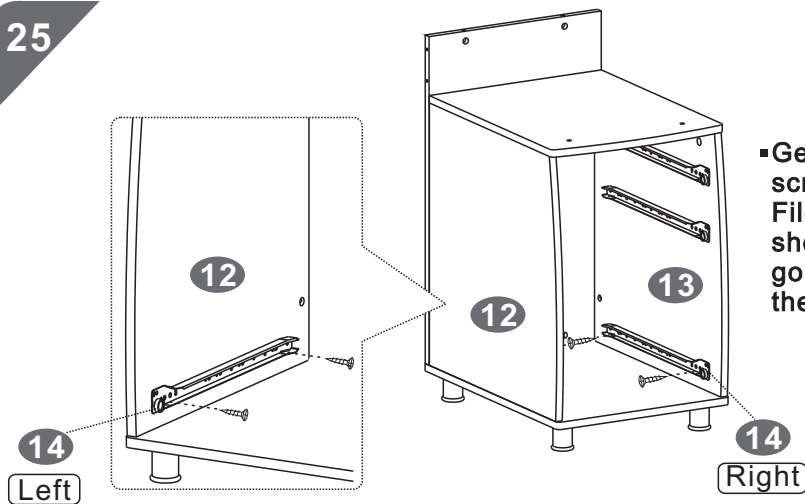

▪ Get the other set of the Flat Sliders (14) and use screws C to assemble them to the bottom of the File Cabinet Left & Right Panels (12 & 13) as shown. Please note: The wheel on the sliders go facing to the FRONT and the screw goes on the hole after the wheel as shown.

▪ SCREWS

C 3X15 MM

4PCS



26

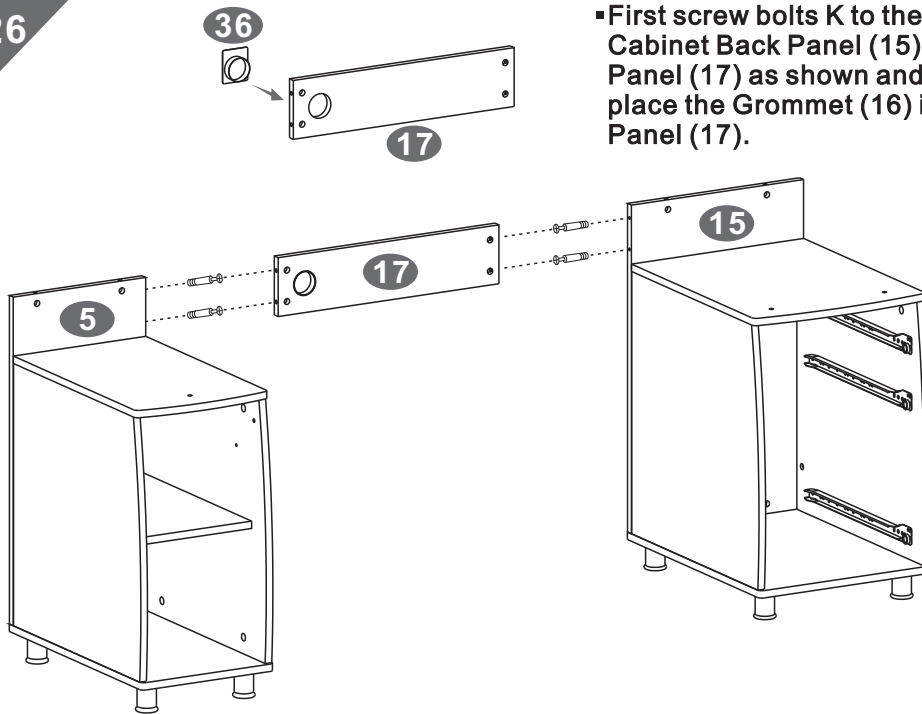

▪ First screw bolts K to the CPU Back Panel (5) and the File Cabinet Back Panel (15), then assemble the Central Panel (17) as shown and as explained in page 5. Finally, place the Grommet (16) into the hole of the Central Panel (17).

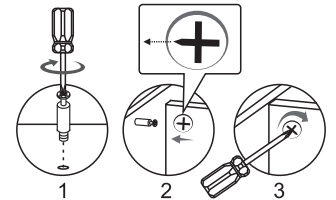

▪ SCREWS

K 6X25 MM

4PCS



27

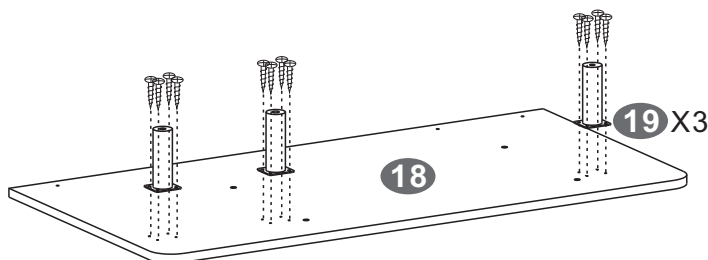

▪ Use screws F to assemble the Supporting Tubes for Main Panel (19) to the Main Panel (18).

▪ SCREWS

F 4X14 MM

12PCS



28

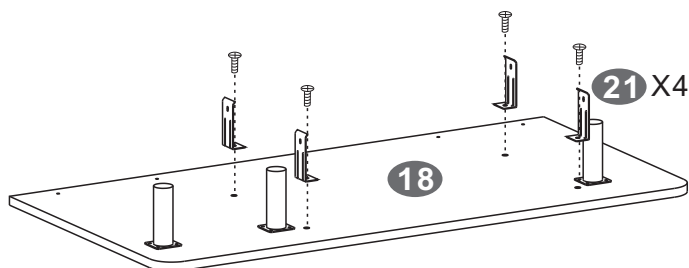

SCREWS

H 6X12 MM

4PCS



Use screws H to assemble the Sliders Bases (21) to the Main Panel (18).

29

Use screws I to assemble the Keyboard Sliders (20) to the Sliders Bases (21) as shown.

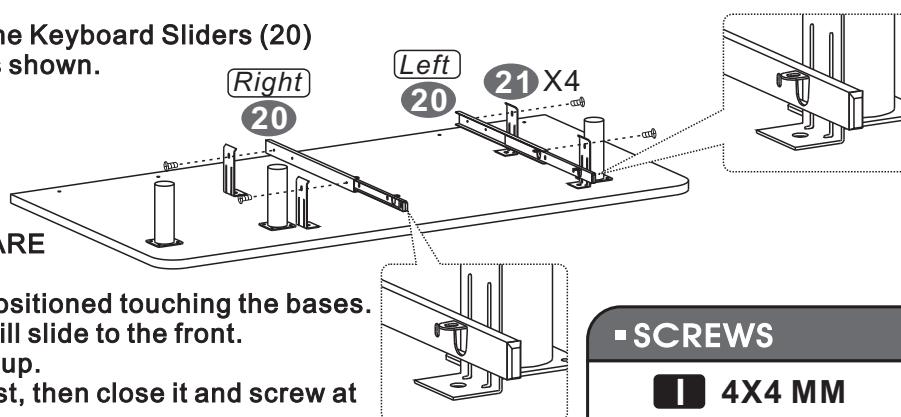

TO MAKE SURE THE SLIDERS ARE ASSEMBLED CORRECTLY:

- The flat side of the sliders are positioned touching the bases.
- The moving part of the sliders will slide to the front.
- The tabs on the sliders will face up.
- Screw the sliders at the back first, then close it and screw at front.
- The screw is inserted from the outside thru the bases and into the holes of the sliders.

SCREWS

I 4X4 MM

4PCS



30

First screw bolts K to the back holes of the Main Panel (18). Then place the washers J over the front holes of the CPU and Drawers cabinets as shown. Finally, and with the help of another person, carefully place the tabletop over the frame of the desk and secure at the front with screws A, and at the back by locking the cam locks as explained in page 5.

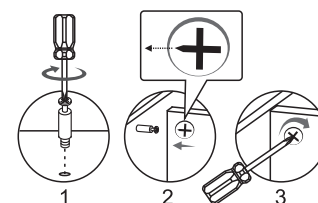
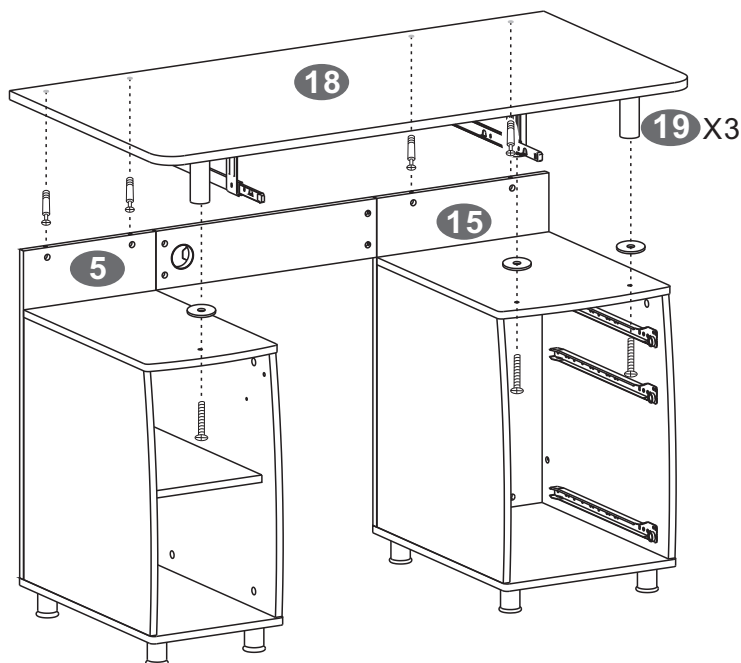

SCREWS

A 6X35 MM

3PCS



J Φ 40 MM

3PCS

K 6X25 MM

4PCS



31

- Open the sliders and place the Keyboard Panel (22) over the tabs, making the holes on the tabs and the panel coincide. Use screws F to secure the panel to the sliders from underneath as shown.

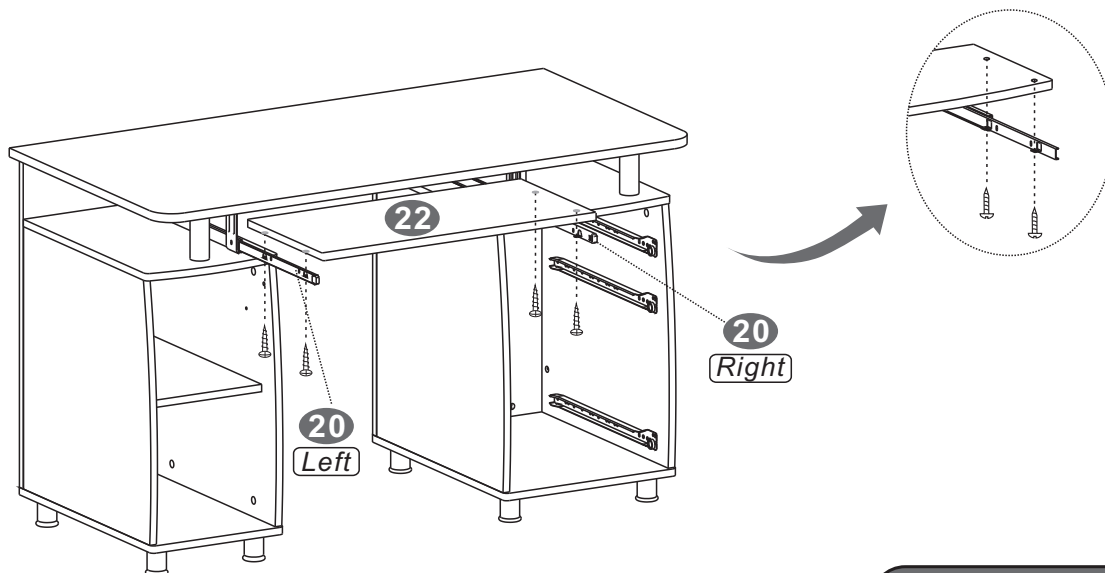

▪ SCREWS

F 4X14 MM

4PCS



32

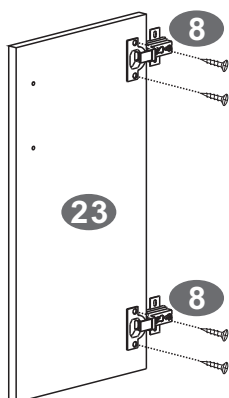

- Use screws C to assemble the Hinges (8) to the CPU Door (23).

▪ SCREWS

G 4X16 MM

4PCS



33

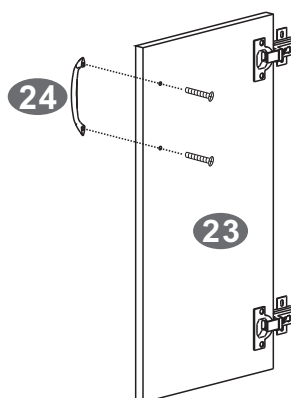

- Use screws D to assemble the Handle (24) to the CPU Door (23).

▪ SCREWS

D 4X20 MM

2PCS



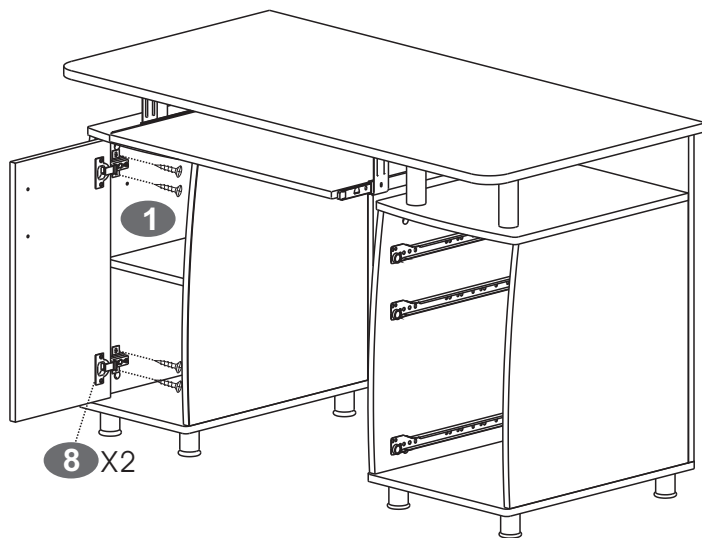

34



■ Use screws G to assemble the Hinges (8) to the CPU Left Panel (1).

■ SCREWS

G 4X16 MM  4PCS 

If the door does not close properly, you can adjust its position by unscrewing loose the corresponding screws on the hinges:

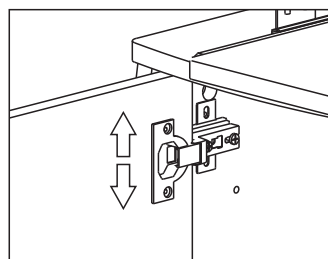

Adjusts the door vertically

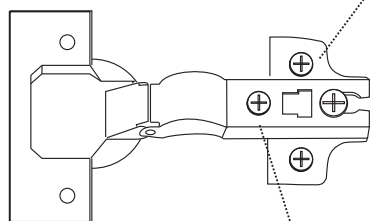

Adjusts the door horizontally

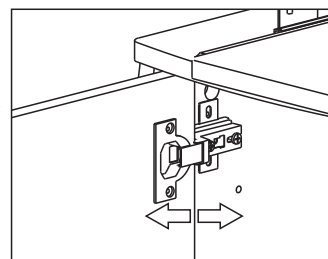

Adjusts the door side-to-side when it is closed.

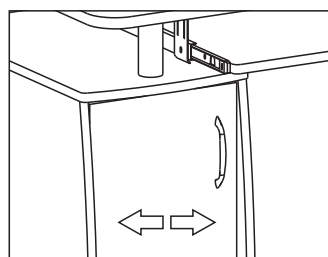

When the optimal position has been reached, re-tighten the screws.

35

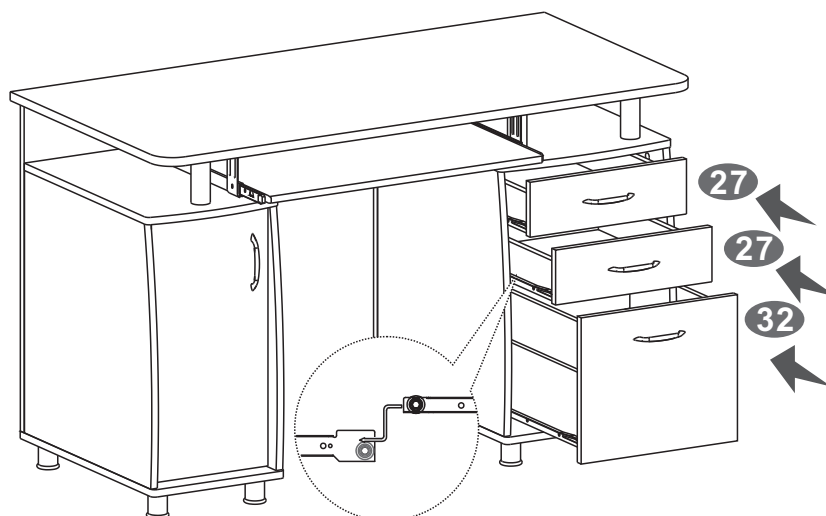

- Insert the drawers into the cabinet, starting with the bottom drawer. For the top drawer, you might have to insert it at a downward tilted angle.

36

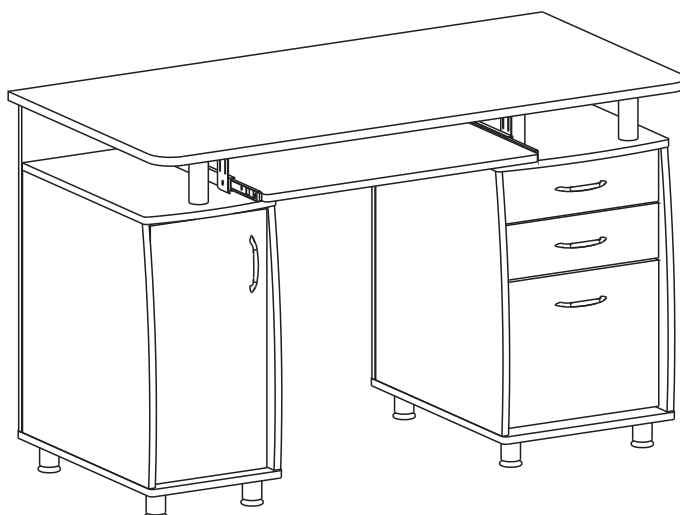

- Tighten any and all screws that are still loose, and ENJOY YOUR NEW UNIT!

CARE AND MAINTENANCE

English

- DO NOT EXPOSE THE SURFACES TO DIRECT SUNLIGHT OR EXTREME ENVIRONMENTAL CONDITIONS. ANY DAMAGE RESULTING FROM SUCH EXPOSURE IS NOT COVERED BY THE PRODUCT'S WARRANTY.
- THE PREFERABLE METHOD TO CLEAN THE SURFACES IS TO WIPE THEM USING A SOFT CLOTH DAMPENED WITH A SOLUTION SOAP AND WATER, THEN DRY WITH A CLEAN TOWEL.
- DO NOT SPRAY SOLVENTS OR CLEANING AGENTS DIRECTLY OVER THE SURFACES, STRUCTURAL TUBES OR METAL PARTS.
- DO NOT LEAN, SEAT OR STAND OVER THE UNIT.
- DO NOT ALLOW CHILDREN TO PLAY OVER/UNDER THE UNIT, NOR ALLOW THEM TO REACH INSIDE ANY COMPARTMENTS WITHOUT THE SUPERVISION OF AN ADULT.
- BEFORE MOVING OR TRANSPORTING THE UNIT, MAKE SURE THAT:
 - ALL HEAVY OBJECTS OR THAT MIGHT FELL OFF ARE REMOVED FROM THE UNIT.
 - IF THE UNIT ARE ON CASTERS (WHEELS), MAKE SURE THAT ALL ARE UNLOCKED.
 - THE UNIT MUST BE HANDLED BY AT LEAST 2 PERSONS.
 - WHEN LIFTING THE UNIT, USE BOTH OF YOUR HANDS, AND BEND YOUR KNEES. REMEMBER TO ALWAYS LIFT WITH YOUR LEGS, NOT YOUR BACK.
- IN CASE OF DAMAGE TO ANY PARTS, NOTIFY THE VENDOR AS SOON AS POSSIBLE.
- IN CASE OF GLASS BREAKAGE (IF THE UNIT HAS A GLASS TABLE TOP OR PARTS MADE OF GLASS) DO NOT HANDLE THE BROKEN GLASS WITH YOUR BEAR HANDS, AND CONTACT THE VENDOR IMMEDIATELY. DO NOT ALLOW CHILDREN NEAR THE BROKEN GLASS.