

ASSEMBLY INSTRUCTION

IMPORTANT: Surfaces must be cleaned with mild soap and water then dried with a clean cloth. Do not use solvents over surfaces or structural tubes.

Thanks for purchasing one of our products, please read the assembly instructions carefully before installation (Attention: Do not tighten the screws before all screws are in place).

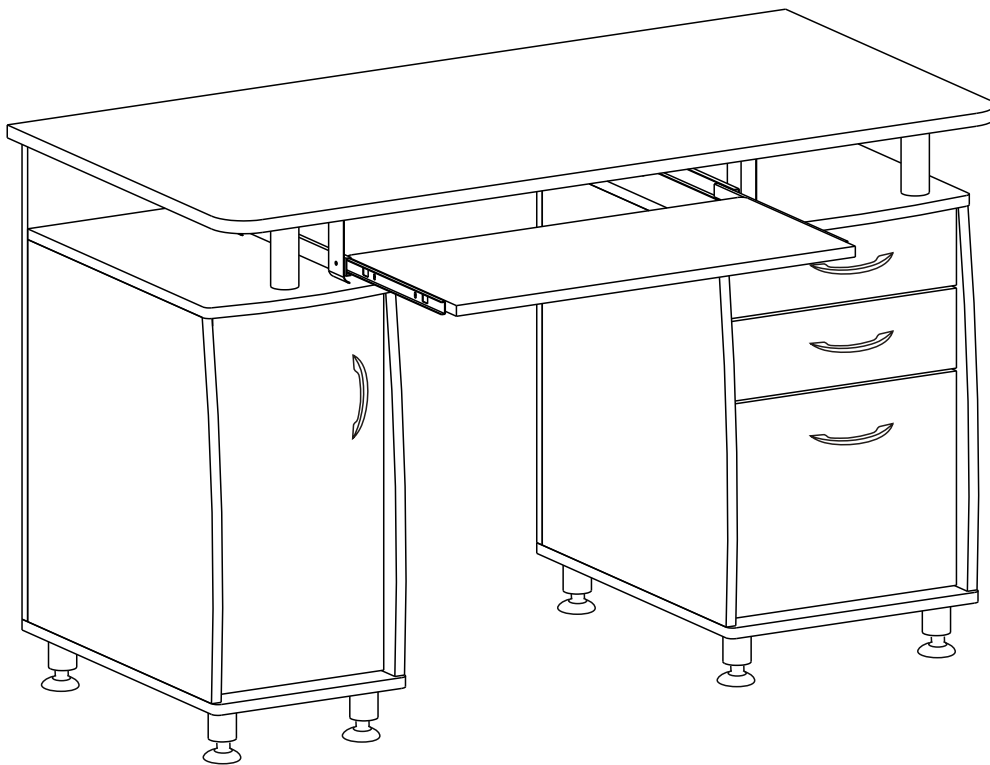







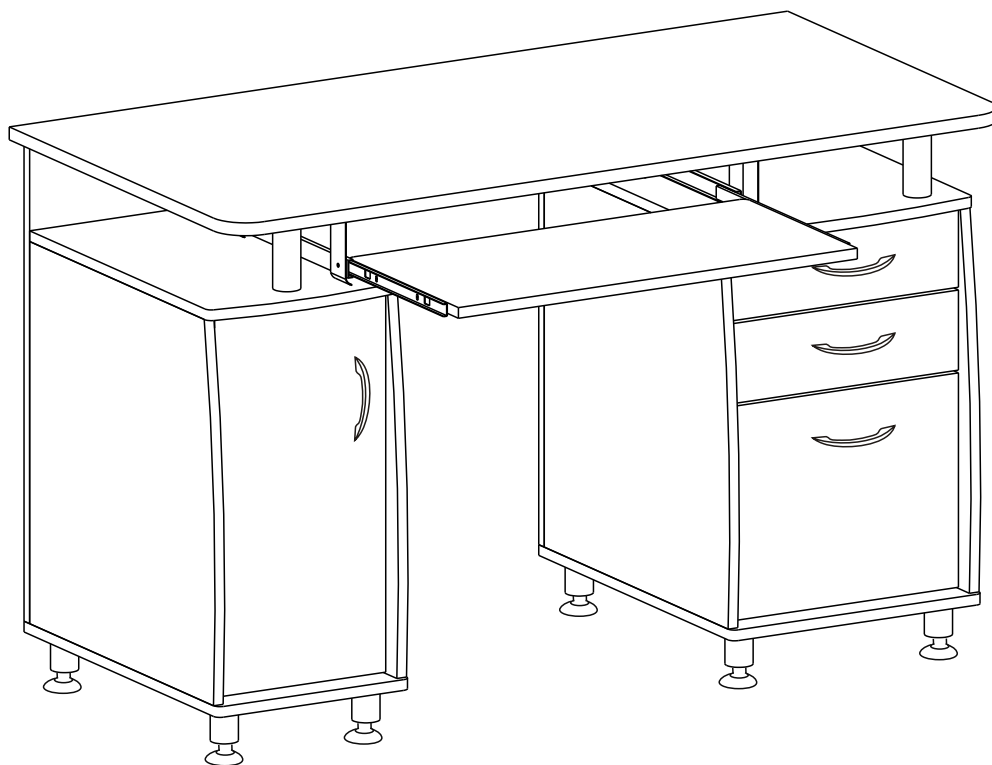





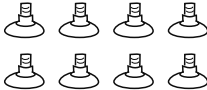

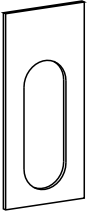
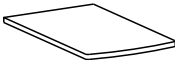

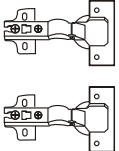

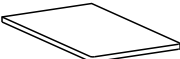
INSTRUCCIONES DE ENSAMBLAJE.

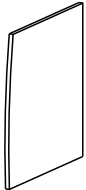

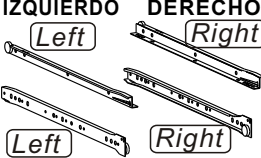
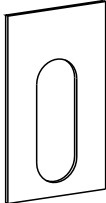

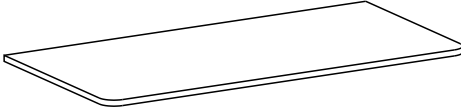

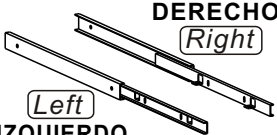
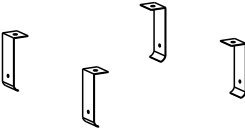
IMPORTANTE: Para su limpieza sobre la superficies utilice una toalla humedecida en una solución de agua y jabón y luego pase un trapo seco. No utilice solventes, sobre las superficie ni las estructuras tubulares.

Gracias por comprar uno de nuestros productos por favor lea cuidadosamente las instrucciones de ensamblaje antes de instalar la unidad.(Atencion: No ajuste firmemente los tornillos antes de tener la estructura completamente armada).



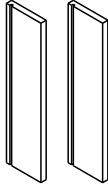
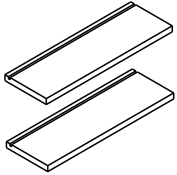
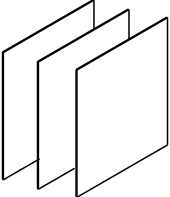
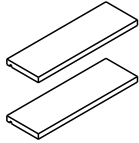

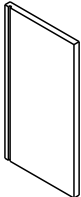
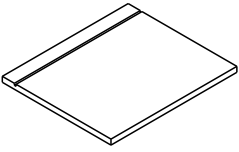
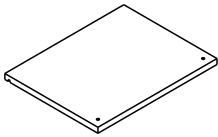

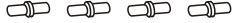



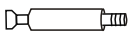

▪ PARTS LIST ▪ LISTA DE PARTES

 <p>1</p> <p>▪ CPU Left Panel ▪ Panel Izquierdo del porta CPU</p>	 <p>2</p> <p>▪ CPU Right Panel ▪ Panel derecho del porta CPU</p>	 <p>3</p> <p>▪ Studs ▪ Patas</p>	 <p>4</p> <p>▪ CPU Bottom Panel ▪ Panel Inferior del Porta CPU</p>
 <p>5</p> <p>▪ CPU Back Panel ▪ Panel Posterior del Porta CPU</p>	 <p>6</p> <p>▪ CPU Top Panel ▪ Panel Superior del Porta CPU</p>	 <p>7</p> <p>▪ Vertical Tubes ▪ Tubos Verticales</p>	 <p>8</p> <p>▪ Hinges ▪ Bisagras</p>
 <p>9</p> <p>▪ Metal Pin ▪ Pin Metalico</p>	 <p>10</p> <p>▪ Auxiliary Panel ▪ Panel Auxiliar</p>	 <p>11</p> <p>▪ Drawer Bottom Panel ▪ Fondo de Gaveta</p>	 <p>12</p> <p>▪ Left Panel ▪ Panel Izquierdo</p>
 <p>13</p> <p>▪ Right Panel ▪ Panel derecho</p>	<p>3PCS</p> <p>IZQUIERDO DERECHO Left Right Left Right IZQUIERDO DERECHO</p>  <p>14</p> <p>▪ Sliders ▪ Deslizadores</p>	 <p>15</p> <p>▪ Right Back panel ▪ Panel Posterior Derecho</p>	 <p>16</p> <p>▪ Drawer's Top Panel ▪ Topo de Gavetero</p>
 <p>17</p> <p>▪ Central Panel ▪ Panel Central</p>	 <p>18</p> <p>▪ Main Panel ▪ Panel Principal</p>	 <p>19</p> <p>▪ Supporting Tubes ▪ Tubos de Soporte</p>	
 <p>DERECHO Right Left IZQUIERDO</p> <p>20</p> <p>▪ Keyboard Slider ▪ Deslizadores de Porta Teclado</p>	 <p>21</p> <p>▪ Slider's Base ▪ Base de Deslizadores</p>	 <p>22</p> <p>▪ Keyboard Panel ▪ Panel de Teclado</p>	 <p>23</p> <p>▪ CPU Door ▪ Puerta de porta CPU</p>

 <p>24</p> <ul style="list-style-type: none"> ▪ Handles ▪ <i>Manijas</i> 	 <p>25</p> <ul style="list-style-type: none"> ▪ Small Drawer Left Panel ▪ <i>Panel Izquierdo de Gaveta simple</i> 	 <p>26</p> <ul style="list-style-type: none"> ▪ SmallDrawer Right Panel ▪ <i>Panel derecho de Gaveta simple</i> 	 <p>27</p> <ul style="list-style-type: none"> ▪ Small Drawer Front Panel ▪ <i>Panel frontal de Gaveta simple</i>
 <p>28</p> <ul style="list-style-type: none"> ▪ Small Drawer Bottom Panel ▪ <i>Panel inferior de Gaveta simple</i> 	 <p>29</p> <ul style="list-style-type: none"> ▪ Small Drawer Back Panel ▪ <i>Panel Posterior de Gaveta simple</i> 	 <p>30</p> <ul style="list-style-type: none"> ▪ Bottom Drawer Left Panel ▪ <i>Panel Izquierdo de Gaveta Grande</i> 	 <p>31</p> <ul style="list-style-type: none"> ▪ Bottom Drawer Right Panel ▪ <i>Panel Derecho de Gaveta Grande</i>
 <p>32</p> <ul style="list-style-type: none"> ▪ Bottom Drawer Front Panel ▪ <i>Panel Frontal de Gaveta Grande</i> 	 <p>33</p> <ul style="list-style-type: none"> ▪ Bottom Drawer Back Panel ▪ <i>Panel Posterior de Gaveta Grande</i> 	 <p>34</p> <ul style="list-style-type: none"> ▪ Hanging Files Tubes ▪ <i> tubo porta Carpeta</i> 	 <p>35</p> <ul style="list-style-type: none"> ▪ Metal Support ▪ <i>Soportes metalicos</i>

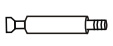
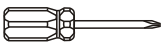

▪ **SCREWS** ▪ **TORNILLOS**

PART	QTY.	ITEM	
A	3	6X35 MM	
B	12	4X30 MM	
C	24	3X15 MM	
D	8	4X20 MM	
E	16	6X40 MM	
F	48	4X14 MM	

PART	QTY.	ITEM	
G	8	4X16 MM	
H	4	6X12 MM	
I	4	4X4 MM	
J	3	WASHER ARANDELA(RONDANA)	
K	32	6X25 MM	
	1	SCREWERIVER ATORNILLADOR	

■ 6X25MM / 6X40MM BOLT INSTALLATION AS BELOW:

■ 6x25mm / 6X40MM INSTALE EL PERONO ASI:

	▪ Bolt ▪ Perno
	▪ Connecting piece ▪ Pieza de ajuste

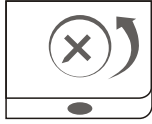
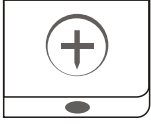
	X INCORRECT incorrecto		✓ CORRECT correcto
<p>▪ Before assembling panels that use the bolt and connecting piece, make sure that the connecting piece is aligned to receive the bolt.</p> <p>▪ Antes de juntar paneles que usan el perno y la pieza de ajuste, asegúrese que la pieza de ajuste esté alineada para recibir el perno.</p>			

A1.

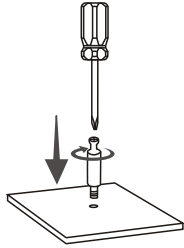

A2.

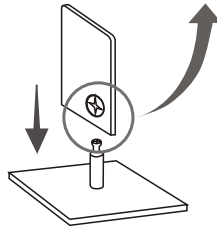

A3.

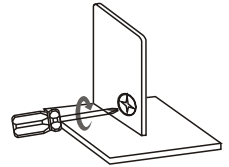

▪ STEPS

▪ PASOS

1

K 4PCS
6X25 MM

- Use the bolts K to fix the Small Drawer Left & Right Panels (25 & 26) to the small Drawer Front Panel (27). Remember to tight the connector at the inside face of the left and right panels (25 and 26)
- Use los Pernos de Ajuste (K) para ensamblar el Panel Izquierdo de Gaveta simple (25) y el Panel Derecho de Gaveta simple (26) con el Panel Frontal de Gaveta Simple (27). Acuerdese de ajustar el conector en la cara interna de los paneles derecho e izquierdo de gaveta simple (25 y 26).

2

- Slide in the Small Drawer Bottom Panel (28).
- Deslize hacia abajo el Fondo de Gaveta (28).

3

B 4PCS
4X30 MM

- Use screws B to assemble the Small Drawer Back Panel (29) with the Small Drawer Left & Right Panels (25 & 26).
- Use Tornillos B para ensamblar el Panel Posterior de Gaveta simple (29) con los Paneles Izquierdo y Derecho de Gaveta Simple (25 & 26).

4

C 4PCS
3X15 MM

DERECHO Right
IZQUIERDO Left

14

- Use screws C to assemble the Sliders (14) to the Small Drawer Left & Right Panels (25 & 26).
- Use los Tornillos C para fijar los Deslizadores (14) a los Paneles Izquierdo y Derecho de Gaveta simple (25&26) alineando los huecos antes de introducir los tornillos.

▪ ALIGN SELECTED HOLES ON SLIDERS AS ILLUSTRATED WITH PRE-DRILLED HOLES ON DRAWER BOX BEFORE INSERTING SCREWS

▪ ALINEE LOS ORIFICIOS SELECCIONADOS DE LOS RIELES CON LOS ORIFICIOS YA TALADRADOS EN LA CAJA DEL CAJÓN ANTES DE INTRODUCIR LOS TORNILLOS

5



D 2PCS

4X20 MM

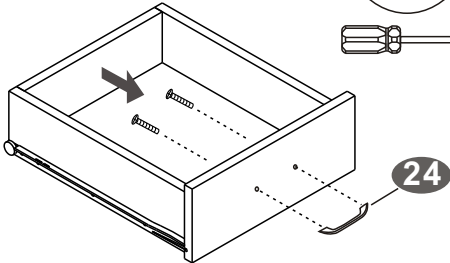
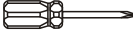
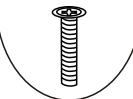

▪ REPEAT FOR THE BOXDRAWER
 ▪ REPITA LA MISMA OPERACIÓN
 PARA LOS TIRADORES DEL CAJÓN

- Use screws D to fix the Handle (24) to the Small Drawer Front Panel (27) Repeat steps for another Small drawer.
- Use Tornillos D para fijar la Manija (24) en el Panel Frontal de Gaveta Simple (27). Repita los mismo pasos para armar otra gaveta simple como la que acaba de ensamblar.

6



K 4PCS

6X25 MM

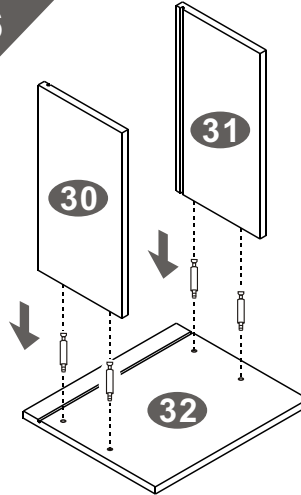
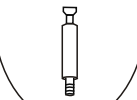

- Use bolts K to fix the Bottom Drawer Left & Right Panels (30 & 31) to the Bottom Drawer Front Panel (32). Remember to tight the connector at the inside face of the left and right panels (30 and 31).

- Use los Pernos de Ajuste K para fijar los Paneles Derecho y Izquierdo de Gaveta Grande (30 & 31) a el Panel Frontal de Gaveta Grande (32) Acuerdese de ajustar el conector en la cara interna de los Paneles Derecho e Izquierdo de Gaveta Grande (30 y 31).

7

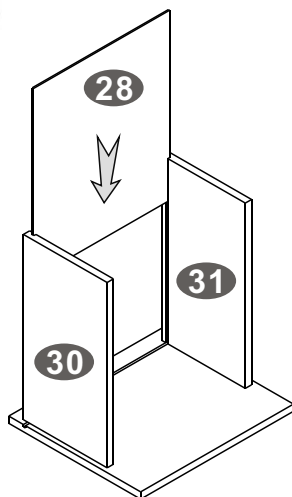

- Slide in the Bottom Drawer Bottom Panel (28).
- Deslize hacia abajo el Fondo de Gaveta Grande (28).

8



B 4PCS

4X30 MM

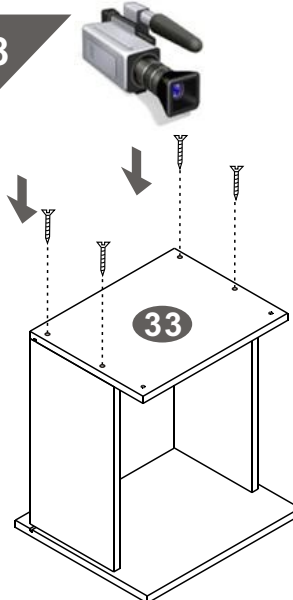

- Use screws B to assemble the Bottom Drawer Back Panel (33) with the Bottom Drawer Left & Right Panels (30 & 31).

- Use Tornillos B para fijar el Panel Posterior de Gaveta Grande (33) a los Paneles Derecho y Izquierdo de Gaveta Grande (30 & 31).

9

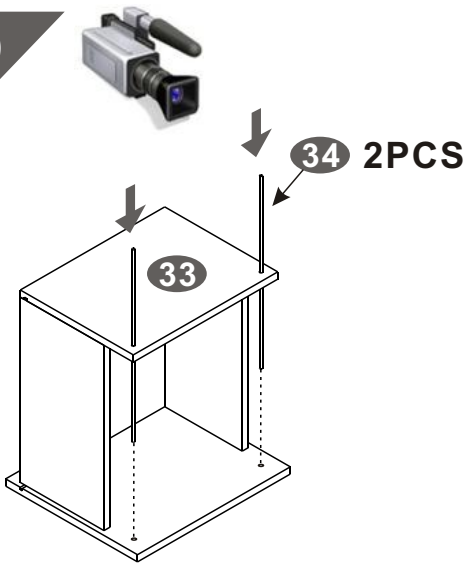

- Insert the Hanging file Tubes (34).
- Inserte los Tubos Porta Carpeta (34).

WARNING:

DO NOT TIGHTEN THE FILE TUBES TOO MUCH BECAUSE IT WILL DAMAGE THE FRONT PANEL OF THE DRAWER.

10

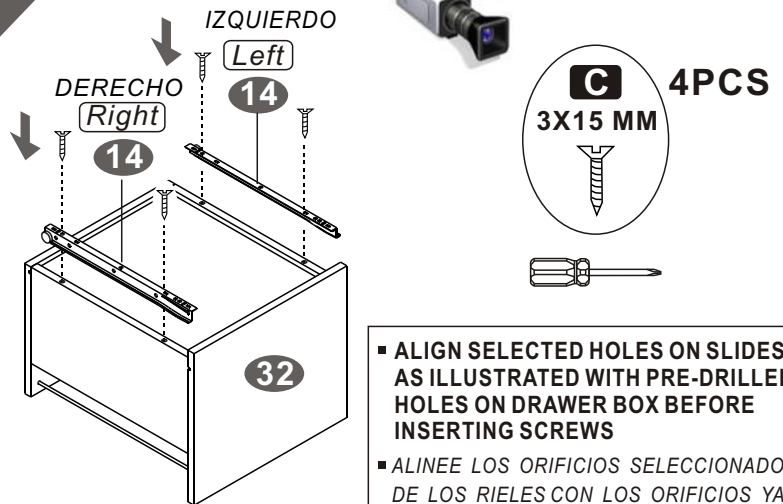

- ALIGN SELECTED HOLES ON SLIDES AS ILLUSTRATED WITH PRE-DRILLED HOLES ON DRAWER BOX BEFORE INSERTING SCREWS
- ALINEE LOS ORIFICIOS SELECCIONADOS DE LOS RIELES CON LOS ORIFICIOS YA TALADRADOS EN LA CAJA DEL CAJÓN ANTES DE INTRODUCIR LOS TORNILLOS

- Use screws C to assemble the Sliders (14) to the Bottom Drawer Left & Right Panels (30&31).
- Use los Tornillos C para fijar los Deslizadores (14) a los Paneles Izquierdo y Derecho de Gaveta Grande (30 y 31) alineando los huecos antes de introducir los tornillos.

11

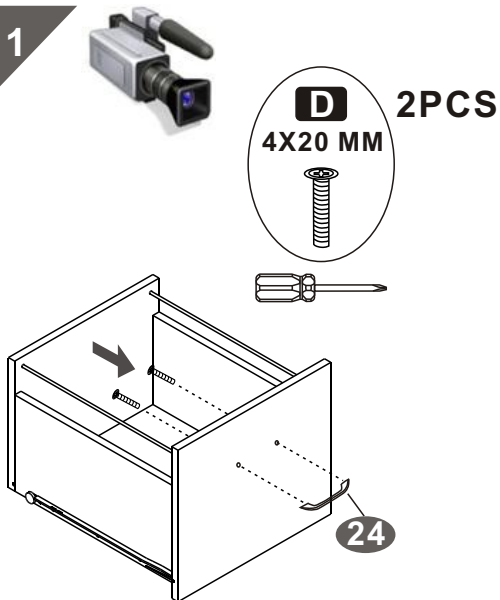

- Use screws D to fix the Handle (24) to the Bottom Drawer Front Panel (32).
- Use Tornillos D para fijar la Manija (24) en el Panel Frontal de Gaveta Grande (32).

12

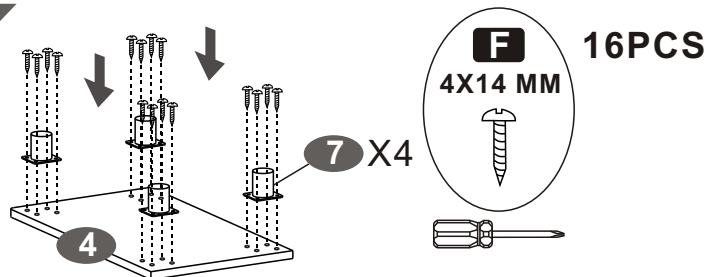

- Use screws F to assemble the Vertical Tubes (7) with the CPU Bottom Panel (4).
- Use Tornillos F para fijar los Tubos Verticales (7) a el Panel Inferior del Porta CPU (4).

13

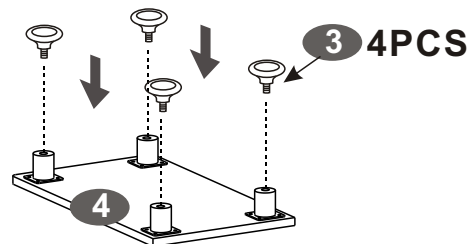

- Insert the Studs (3) into the Vertical Tubes (7) and tight them well.
- Inserte las Patas (3) a los Tubos Verticales (7) y ajustelos bien.

14

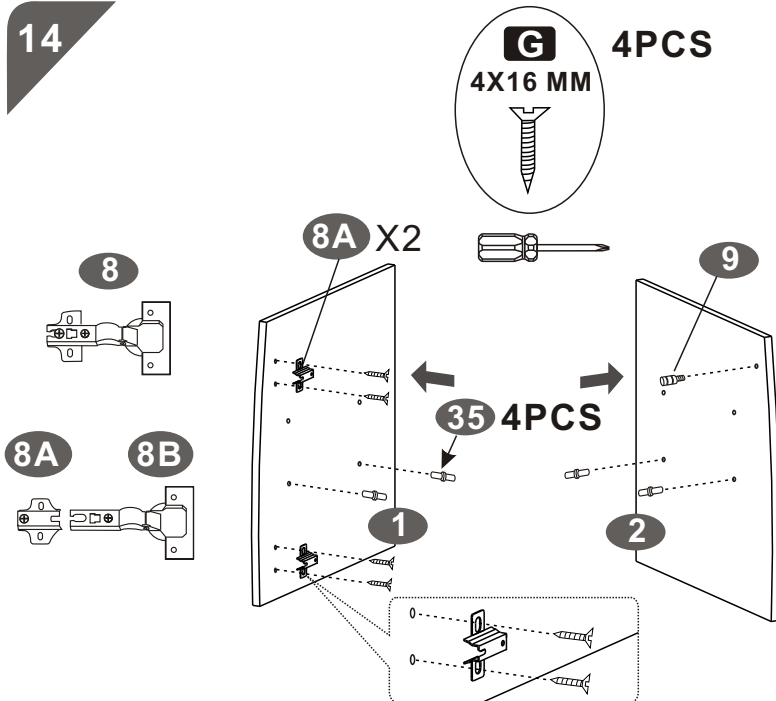

- Separate the Hinges (8) into 8A and 8B. Use screws G to fix the part 8A to the CPU Left & Right Panels (1 & 2). Insert the Metal Supports (35) and the Metal Pin (9) to CPU Left & Right Panels (1 & 2).
- Separe las Bisagras (8) en dos 8A y 8B. Use los tornillos G para fijar las partes 8A a los Paneles Derecho y Izquierdo del porta CPU (1 & 2). Inserte los Soportes Metalicos (35) y un Pin Metalico (9) en los Paneles Derecho y Izquierdo del porta CPU (1 & 2).

15

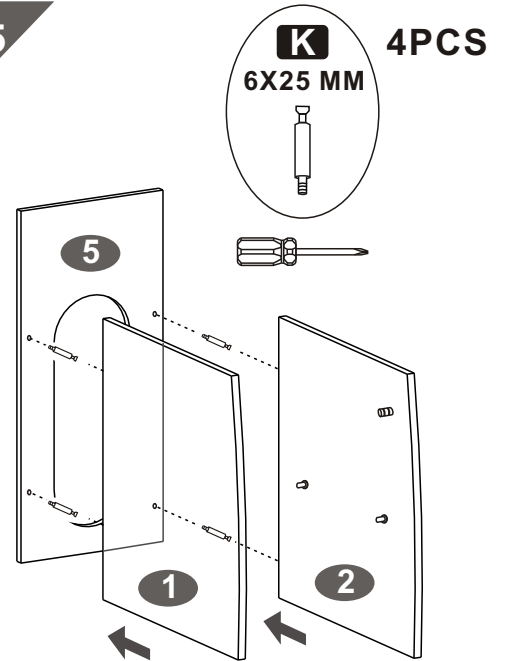

- Use bolts K to fix the CPU Left & Right Panels (1 & 2) to the CPU Back Panel (5). Tight the connectors on the inside faces
- Use los Pernos de Ajuste K para juntar los Paneles Derecho y Izquierdo del porta CPU (1 & 2) con el Panel Posterior del Porta CPU (5). Ajuste los conectores en las caras internas.

16

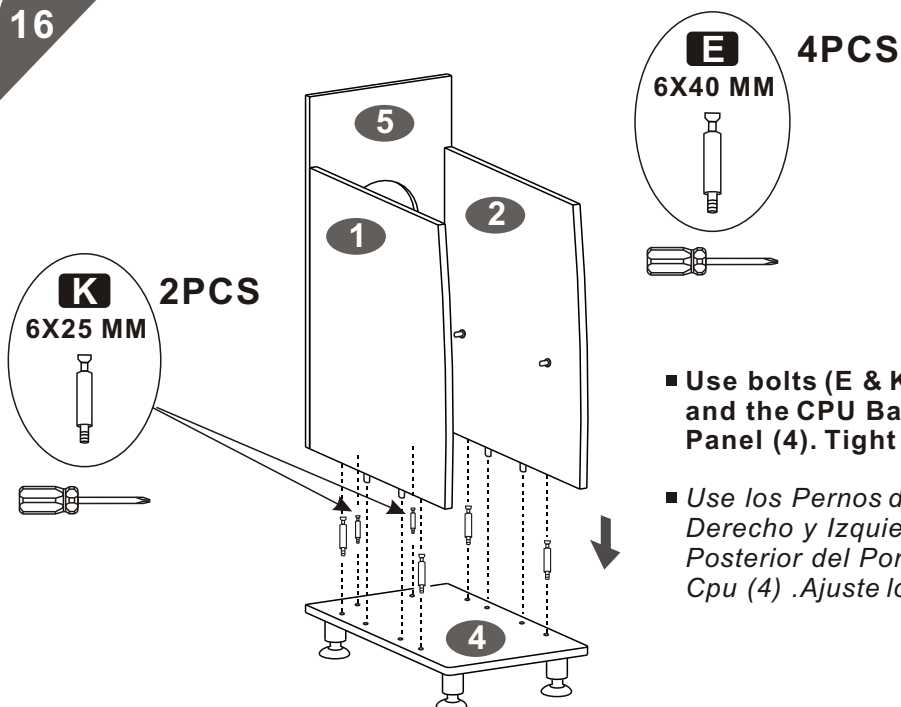

- Use bolts (E & K) to fix the CPU Left & Right Panels, and the CPU Back Panel (5) to the CPU bottom Panel (4). Tight the connectors in the inside faces
- Use los Pernos de Ajuste E&K para juntar los Paneles Derecho y Izquierdo del porta CPU (1 & 2), y el Panel Posterior del Porta CPU (5) al Panel Inferior del Porta Cpu (4) .Ajuste los conectores en las caras internas.

17

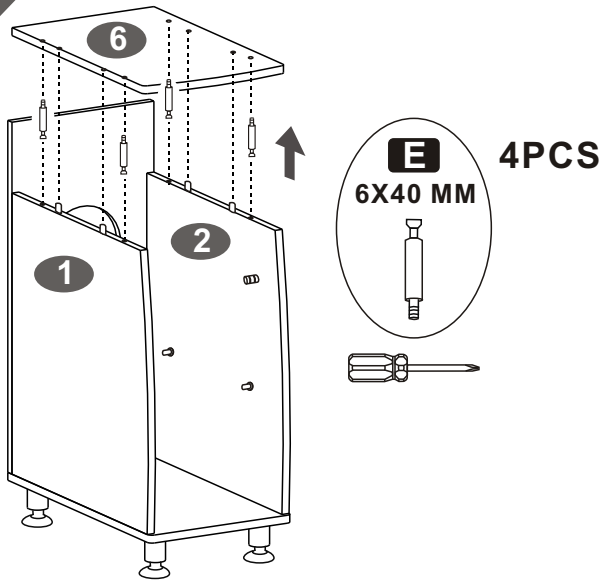

- Use bolts (E) to fix the CPU Left & Right Panels (1 & 2) to the CPU Top Panel (6).
- Use los Pernos de Ajuste (E) para fijar los Paneles Derecho y Izquierdo del porta CPU (1 & 2) a el Panel Superior del Porta CPU (6).

18

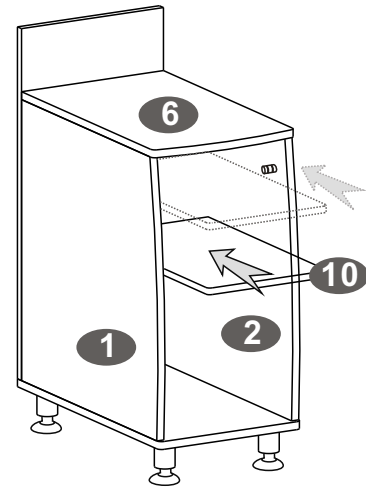

- Slide in the Auxiliary Panel (10) over the Metal Suportes (35)
- Coloque el Panel Auxiliar (10) sobre los soportes metalicos (35).

19

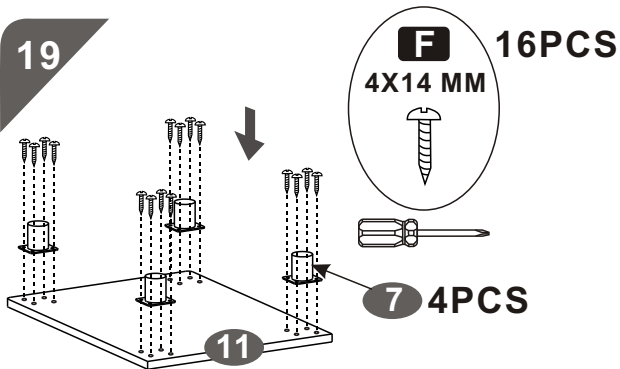

- Use screws F to assemble the vertical Tubes (7) to the Drawer Bottom Panel (11).
- Use Tornillos F para fijar los Tubos Verticales (7) con el Fondo de Gaveta (11).

20

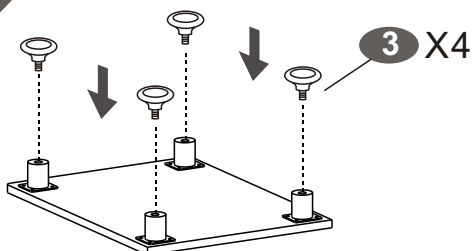

- Insert the studs (3) to the Vertical Tubes (7) and tight them well.
- Inserte las Patas (3) a los Tubos Verticales (7) y ajustelos bien.

21

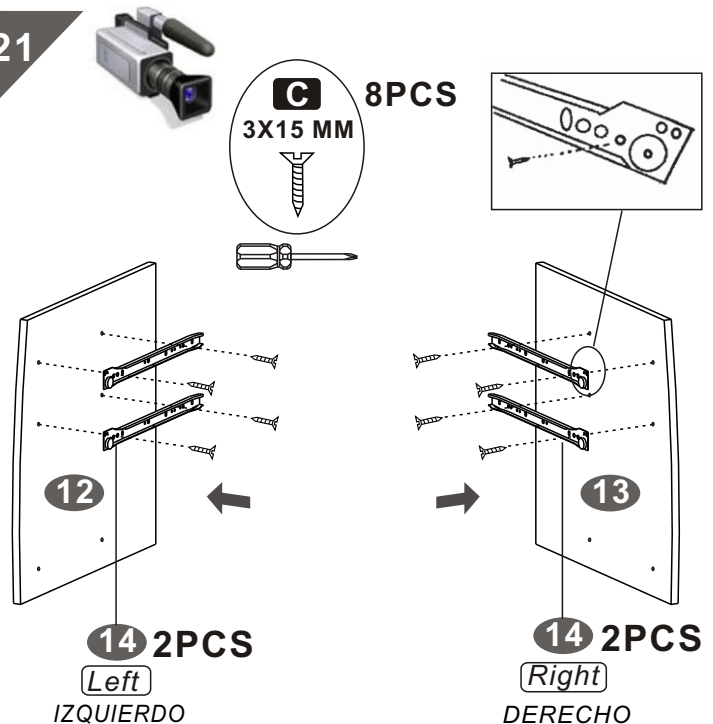

- Use screws C to assemble the sliders (14) to Left & Right Panels(12 & 13).
- Use los Tornillos C para ensamblar los Deslizadores (14) con los Paneles Derecho y Izquierdo (12 & 13).

22

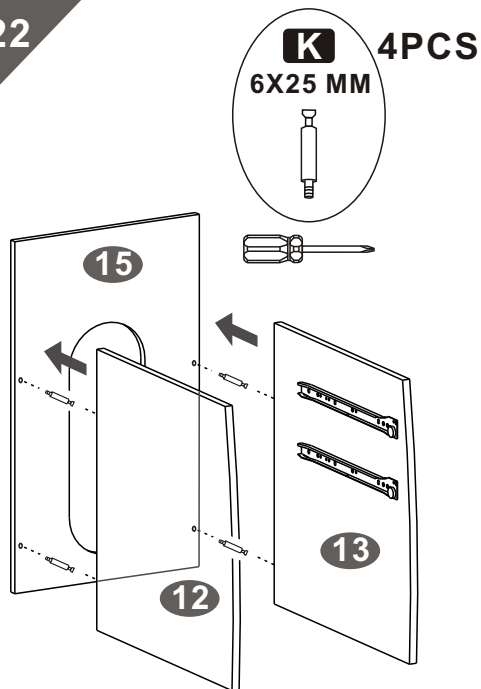

■ Use Bolts K to fix the Left & Right Panels (12 & 13) to the Right Back Panel (15). Make sure to tight the screws in the inside face of the Left and Right Panels (12 & 13).

■ Use los Pernos de Ajuste K para juntar los Paneles Derecho y Izquierdo (12 & 13) al Panel Posterior derecho (15). Asegurese de ajustar los conectores en la cara interior de los Paneles Derecho y Izquierdo (12 & 13).

23

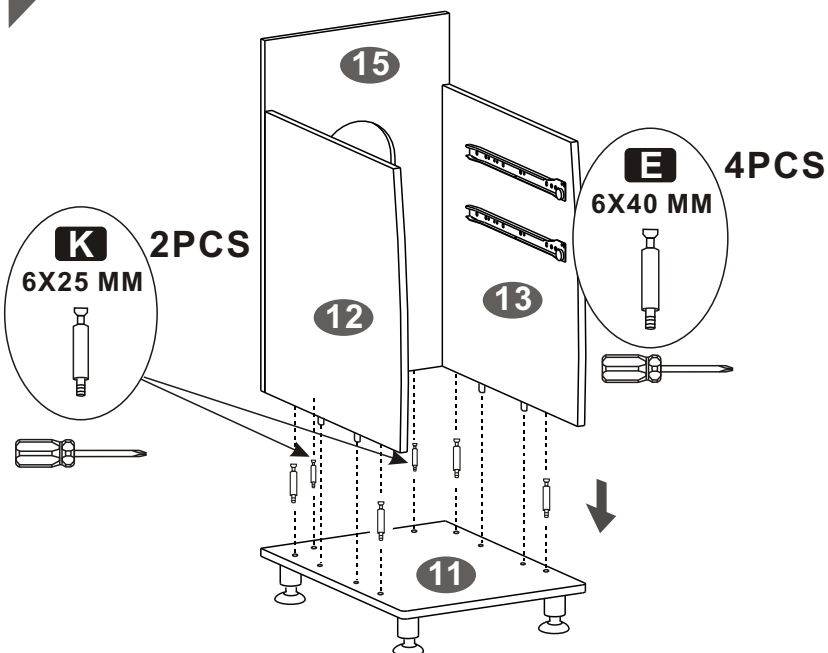

■ Use Bolts E&K to fix the Left, Right & Right Back Panels (12, 13 & 15) to the Drawer Bottom Panel (11). Make sure to tight the connectors in the inside face of the Left, Right & Right Back Panels (12, 13 & 15).

■ Use los Pernos de ajuste (E&K) para juntar los Paneles Izquierdo, Derecho y Posterior (12, 13 & 15) al Fondo de Gaveta. Asegurese de ajustar los conectores en la parte interior los Paneles Izquierdo, Derecho y Posterior (12, 13 & 15).

24

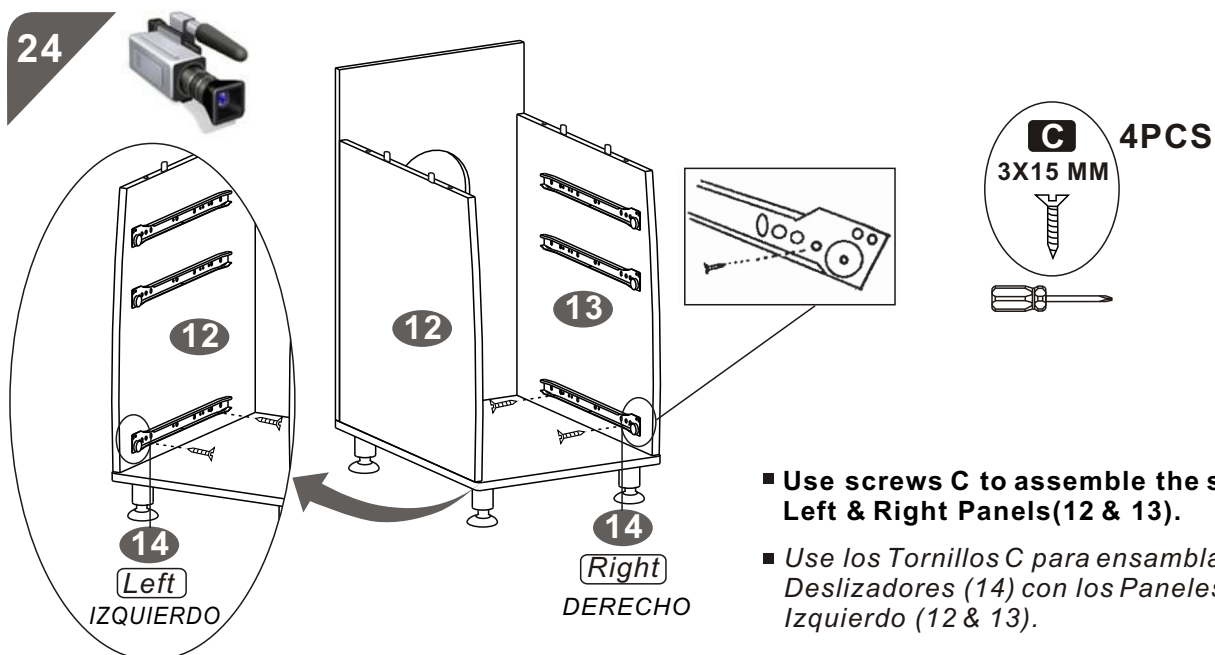

■ Use screws C to assemble the sliders (14) to Left & Right Panels (12 & 13).

■ Use los Tornillos C para ensamblar los Deslizadores (14) con los Paneles Derecho y Izquierdo (12 & 13).

25

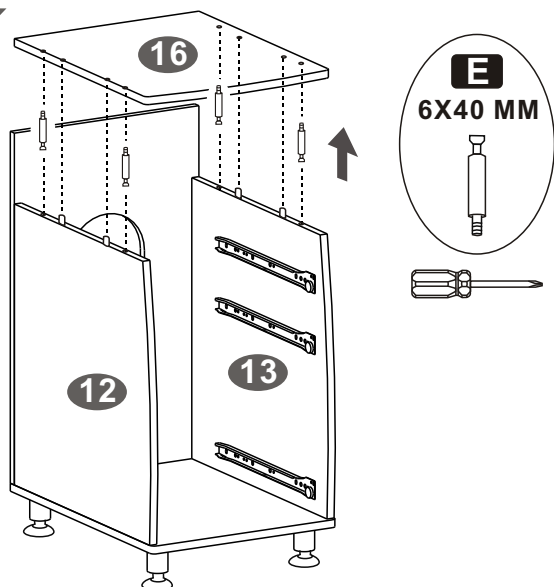

4PCS

6X40 MM

■ Use Bolts E to fix the Drawer Top Panel (16) to the Left & Right Panels (12 & 13). Make sure to tight the screws in the inside face of the Left & Right Panels (12 & 13).

■ Use los Pernos de Ajuste (E) para juntar el Tapa de Gavetero (16) a los Paneles Izquierdo y Derecho (12 & 13). Asegurese de ajustar bien los conectores en la parte interior de los Paneles Izquierdo y Derecho (12 & 13).

26

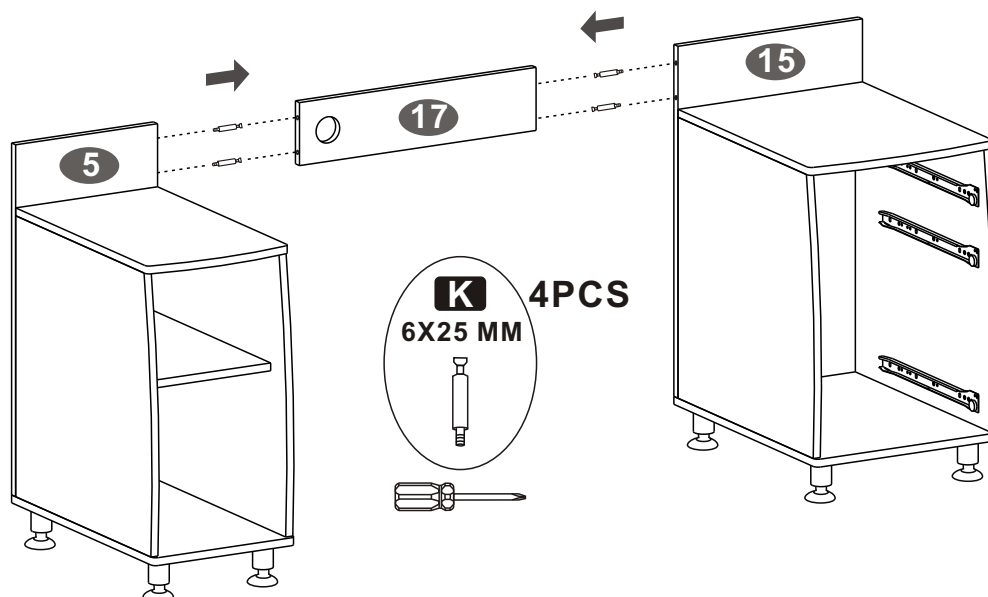

4PCS

6X25 MM

■ Use Bolts K to fix the Central Panel (17) to the CPU Back & Right Back Panels (5 & 15). Make sure to tight the screws in the back face of the Central Panel (17).

■ Use los Pernos de Ajuste K para fijar el Panel Central (17) con el Paneles Posterior de CPU (5) y el Panel Posterior Derecho (15). Asegurese de ajustar los conectores en la parte trasera del Panel Central (17).

27

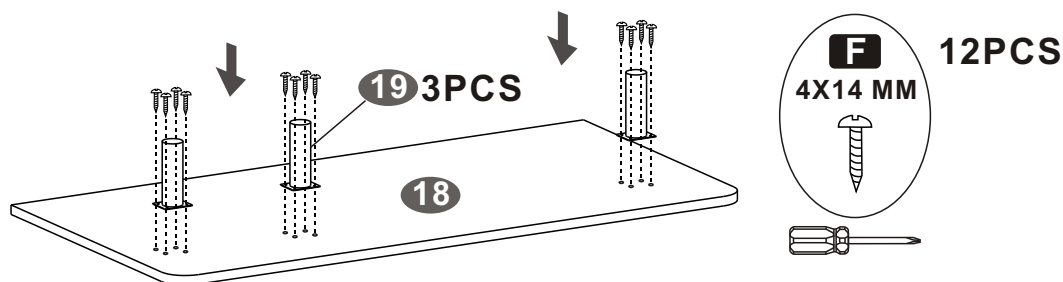

19 3PCS

18

12PCS

4X14 MM

■ Use screws F to assemble the Supporting Tubes (19) to the back face of the Main Panel (18)

■ Use Tornillos F para juntar los Tubos de Soporte (19) con la cara posterior del Panel Principal (18).

28

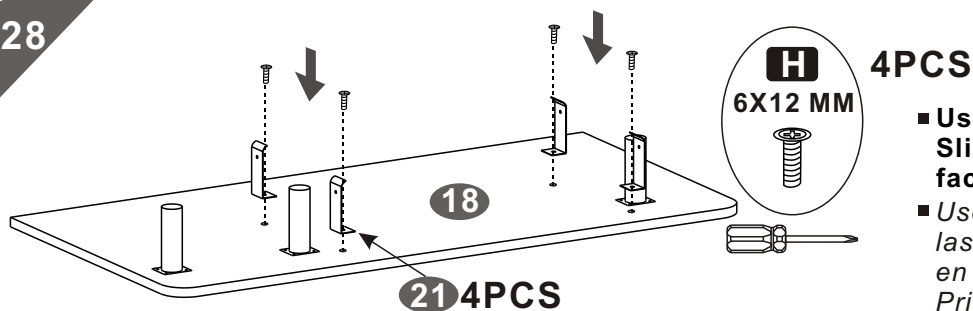

- Use screws H to assemble the Slider's bases (21) to the back face of the Main Panel (18).
- Use los Tornillos H para ensamblar las Bases de los Deslizadores (21) en la cara posterior del Panel Principal (18).

29

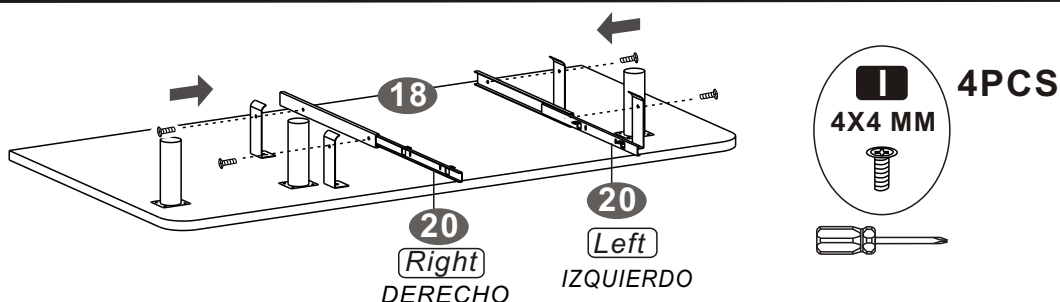

- Use screws I to assemble the Keyboard Sliders(20) to the Slider's bases (18). Check that the sliders slide out to the correct direction.
- Use los Tornillos I para Ensamblar los Deslizadores de Porta Teclado (20) con ls Bases de los Deslizadores ensambladas en el paso anterior sobre el Panel Principal (18) Fijense que deslicen hacia el frente del Mueble.

30

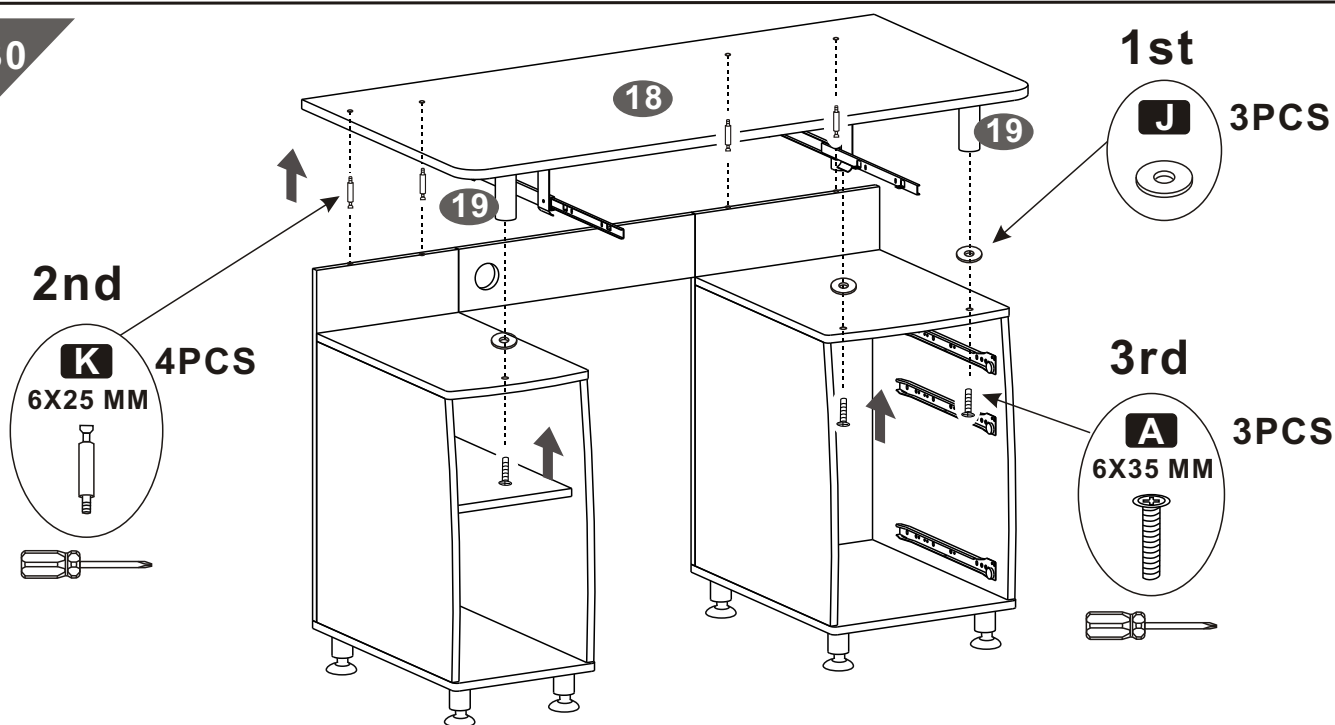

- Place Bolts K into the back face of the Main Panel (18) and match them with the holes on the Back panels of the structure which has been assembled. Tight the connectors. Then Use screws A to assemble the Supporting Tubes (19) to the Cpu and Drawer's Top Panels, placing the Washers J between the panels and the supporting tubes.
- Coloque los Pernos de Ajuste Ka los huecos de la Cara posterior del Panel Principal (18) y luego haga coincidir estos pernos en los huecos de los paneles posteriores de la estructura ya armada, ajuste los conectores. Luego use Tornillos A para fijar los tubos de Soporte (19) a los paneles superiores de Gaveta y Cpu, poniendo primero las arandelas J entre los Tubos Y los Paneles.

31

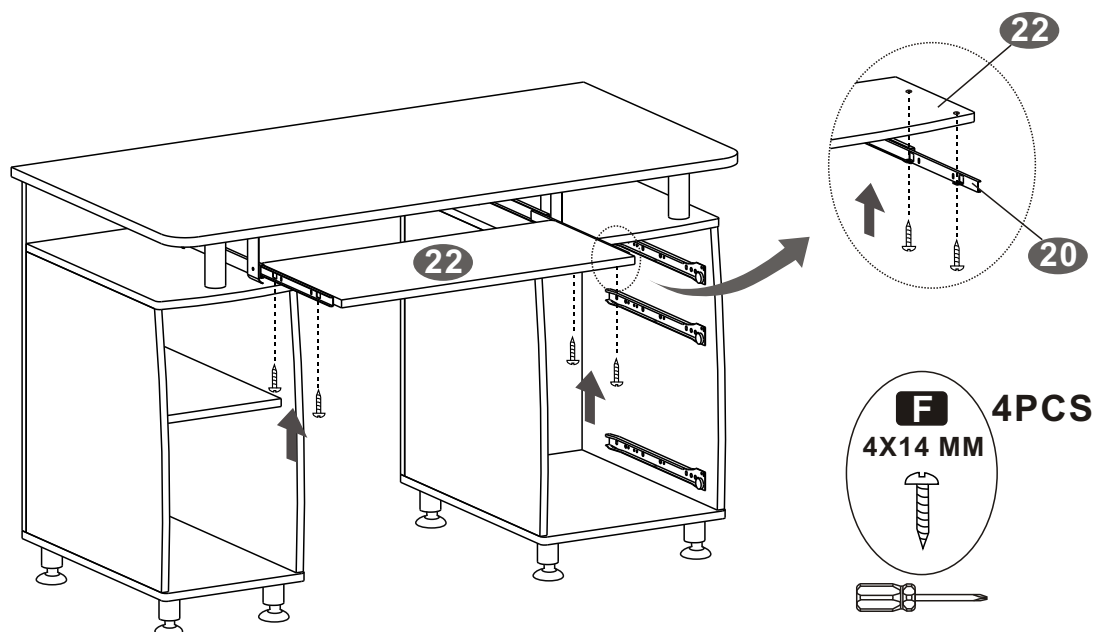

- Use screws F to fix the Keyboard Panel (22) to the Sliders (14) from the back face of Keyboard Panel (22).
- Use los Tornillos F para fijar el Panel de Teclado (22) a los deslizadores (14) desde la cara Posterior del Panel de Teclado (22).

32

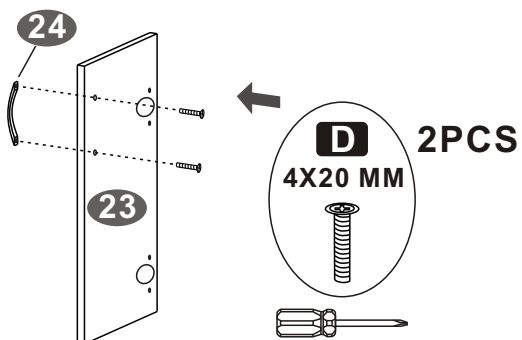

- Use screws D to assemble the Handle (24) to the CPU Door (23).
- Use los Tornillos D para ensamblar la Manija (24) a la Puerta de porta CPU (23).

33

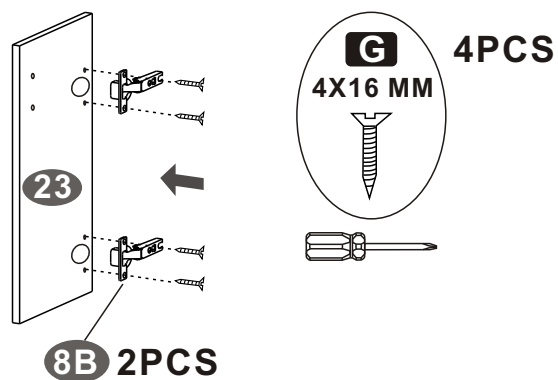

- Use screws G assemble the other part of the Hinges (8B) to the CPU Door (23).
- Use los Tornillos G para fijar las partes de Bisagra (8B) a la Puerta de porta CPU (23).

34

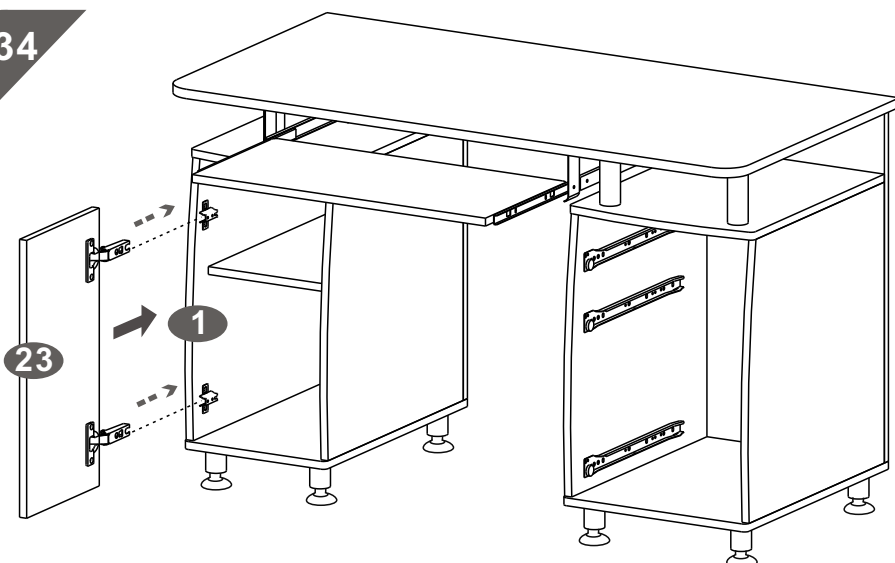

- This direction for tighten, reverse for separating or adjust fitting's distance
- Apriete los tornillos en esta dirección, y en dirección contraria para separar o ajustar la distancia de las placas metálicas

- Assemble the two parts of the Hinges (8A&B) and fix them with the screw driver.
- Inserte la Puerta Porta CPU (23) ensamblando ambas partes de las Bisagras (8A y B) y ajústelos con un destornillador.

35

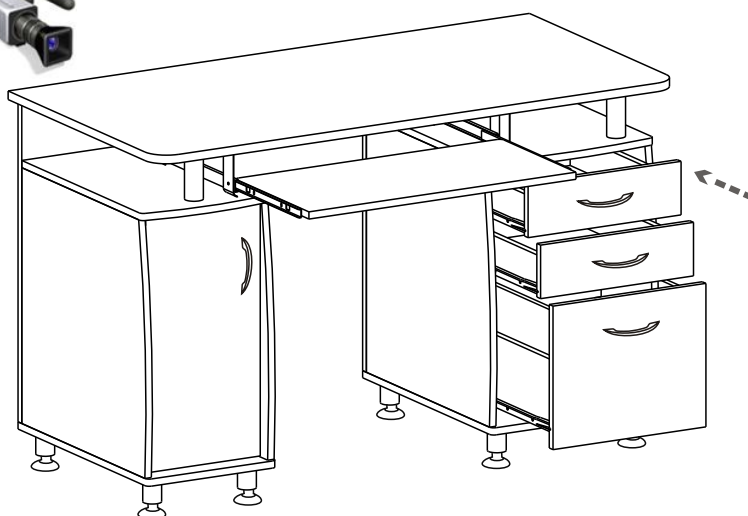

- Top drawer might need to be inserted at an angle (upward inclination \)
- La gaveta superior necesitará meterse en ángulo. (hacia arriba \)

- Slide in all Drawers.
- Deslize las Gavetas en su lugar.

36

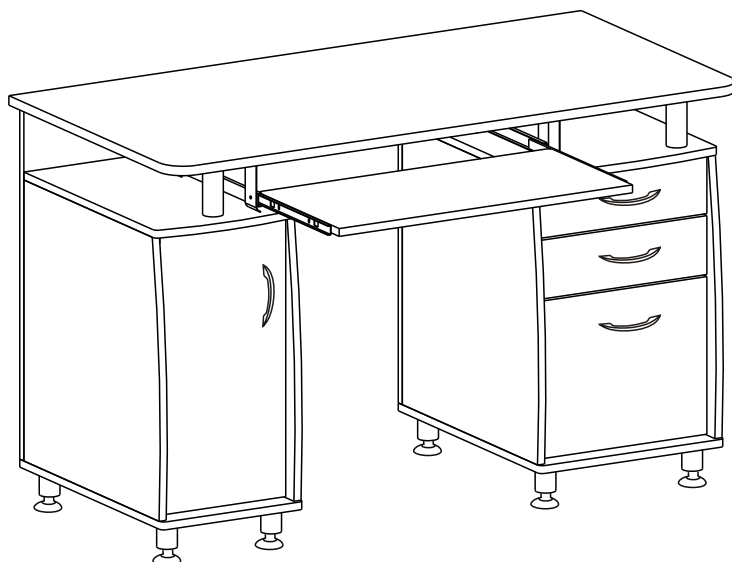

- Tight all screws well and enjoy your unit.
- Ajuste bien todos los Tornillos y DISFRUTE SU ESCRITORIO!