

ASSEMBLY INSTRUCTIONS (KITCHEN CABINET)

~ Before assembly, please read the instructions ~ ~ Follow these steps to assemble the Kitchen Cabinet ~
~ Keep these instructions for future reference ~

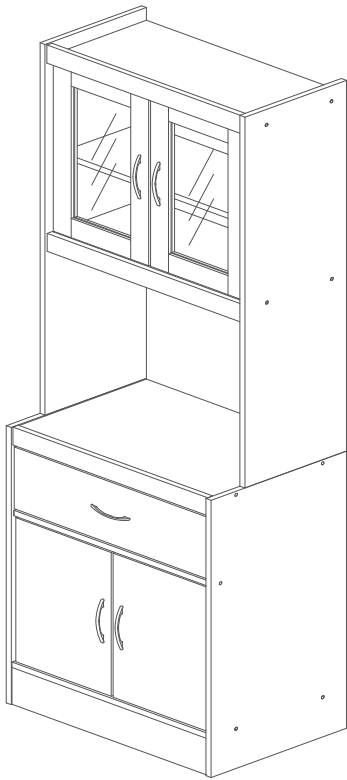

FRONT VIEW

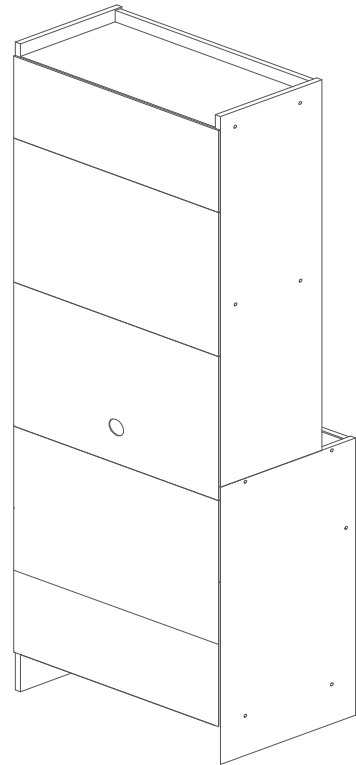

BACK VIEW



THIS INSTRUCTION BOOKLET CONTAINS IMPORTANT INFORMATION ABOUT ASSEMBLY AND SAFETY. PLEASE READ AND KEEP FOR FUTURE REFERENCE.

Parts

① Down Side Panel (Left)
1 pcs
770 x400x 15mm

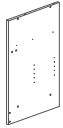

② Middle Support
1 pcs
576 x66x 15mm

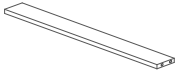

③ Bottom Panel
1 pcs
576 x398 x 15mm

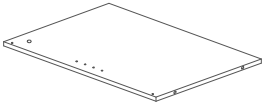

④ Leg Panel
1 pcs
576 x103 x 15mm

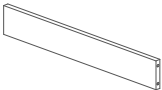

⑤ Middle Panel
1 pcs
576 x380x 15mm

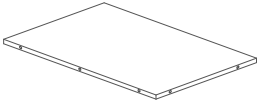

⑥ D-Moulding
1 pcs
576 x 51x 15mm

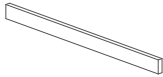

⑦ Down Side Panel (Right)
1 pcs
770 x400x 15mm



⑧ Up Side Panel (Left)
1 pcs
1030 x300x 15mm



⑨ Middle Panel
1 pcs
576 x 280 x 15mm



⑩ D-Moulding
1 pcs
576 x 51x 15mm

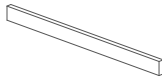

⑪ Top Panel
1 pcs
576 x 280 x 15mm



⑫ D-Moulding
1 pcs
576 x 51x 15mm

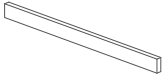

⑬ Up Side Panel (Right)
1 pcs
1030 x300x 15mm



⑭ Back Panel
2 pcs
605 x 400 x 15mm



⑮ Back Panel
2 pcs
605 x400x 15mm



⑯ Back Panel
1 pcs
605 x 400 x 15mm



⑰ Shelf Panel
1 pcs
576 x246x 15mm



⑱ Shelf Panel
1 pcs
576 x235x 15mm



⑲ Drawer Head
1 pcs
568 x171x 15mm



⑳ Drawer Front & Back
1 pcs
520 x116 x 15mm



㉑ Drawer Side R/L
2 pcs
357 x116x 15mm



㉒ Drawer Bottom Panel
1 pcs
549 x357x 2.5mm

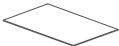

㉓ Door Panel (Left)
1 pcs
400 x 282 x 15mm



㉔ Door Panel(Right)
1 pcs
400 x 282 x 15mm



㉕ Glass Door Panel (Left)
1 pcs
474 x 282 x 15mm



㉖ Glass Door Panel (Right)
1 pcs
474 x 282 x 15mm





The parts of the product are packed in one box.
There are inner box(es) or package(s) that included components and accessories required to complete the assembly

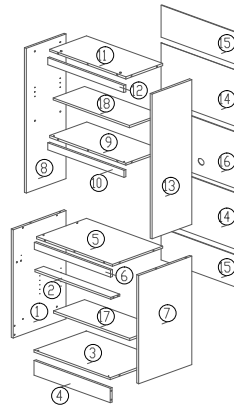



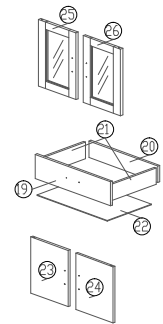





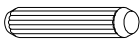



I) Main Unit :

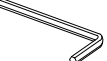

II) Door & Drawer :



Hardware And Accessories

A Wood Dowel 8x25mm 9 pcs 	B Wood Dowel 8x40mm 4 pcs 	C CB Screw M3x12mm 4 pcs 	D CB Screw M3.5x16mm 12 pcs 	E CB Screw M4x25mm 8 pcs 	F CB Screw M4x38mm 10 pcs 
G CSK Cap Wood M6x50MM 18 pcs 	H Screw Cap 24 pcs 	I L Key 1 pcs 	J Metal Shelf Support 8 pcs 	K Door Support Spring 8 pcs 	L Moon Handle 96mm-(PVC) 5 pcs 
M Minifix 5654+5546 6 Sets 	N 3.5KG Magnet(1 Hole) 4 Sets 	O Nail 5/8 50 pcs 	P Furniture Glue(10G) 1 pcs 	Q Drawer Slide 14' 1 set 	



IMPORTANT

Check the measure of the bolts on the scale below or with a measuring tape before applying them in the parts

Observe correctly the application and the position of each bolt accessory, as the step-by-step instructions, before applying them in the parts.

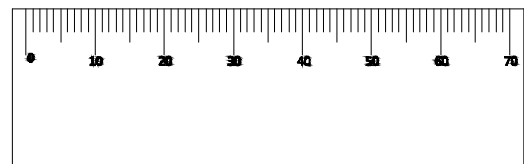

Required Or Recommended Tools

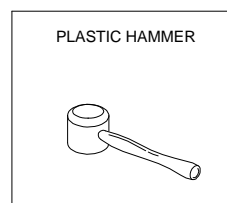
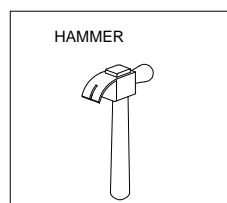
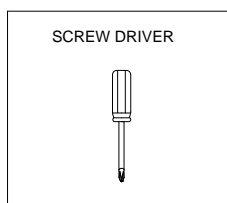

IMPORTANT!

The required or recommended tools for assembly are not supplied with the product.

- This product contains small components, please ensure that they are kept away from small children.
- THIS INSTRUCTION BOOKLET CONTAINS **IMPORTANT SAFETY INFORMATION**. PLEASE READ AND KEEP FOR FUTURE REFERENCE.

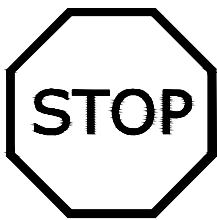

DO NOT RETURN PRODUCT TO THE STORE.

If a part is missing or damaged, email our customer service. We will gladly ship your replacement parts **FREE** of charge.

Need Parts or Assistance?

email us at

For prompt, reliable service; please have your assembly manual ready.

READ BEFORE BEGINNING ASSEMBLY

- Read each step carefully. It is very important that each step of instruction is performed in the correct order. If these steps are not followed in sequence, assembly difficulties will occur.
- Make sure all parts are included. Most parts are labelled or stamped on the raw edge.
- Work in spacious area, preferably on a carpet, near the place the unit will be used.
- Do not use power tools to assemble your furniture. Power tools may strip or damage the parts.

HELPFUL HINTS

- Call us if you need assistance.
- Move your new furniture carefully, with two people lift and carry the unit to it's new location.
- Never push, drag or pull your furniture (especially on carpet).

Warranty Information

Pre - Assembly

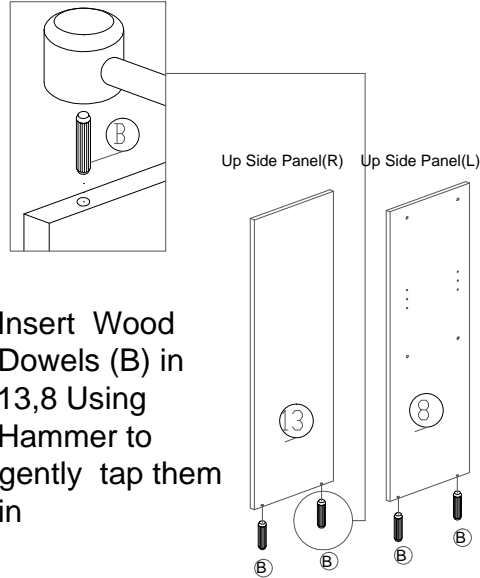
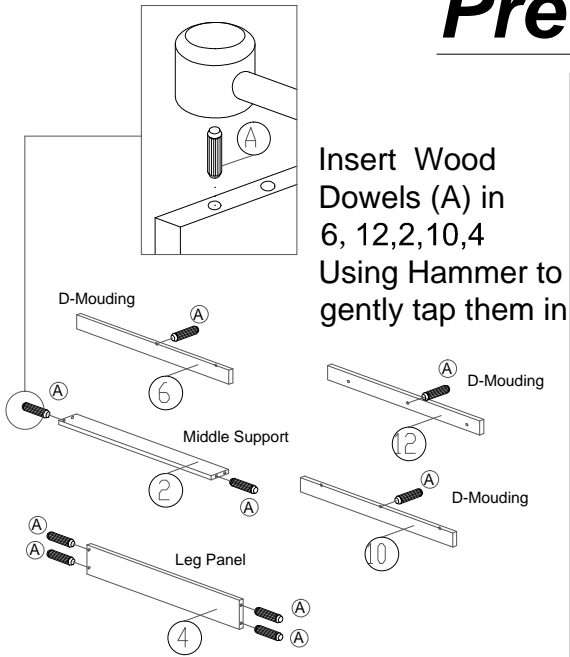

Tighten minifix (M2) to panel (6, 10, 12)

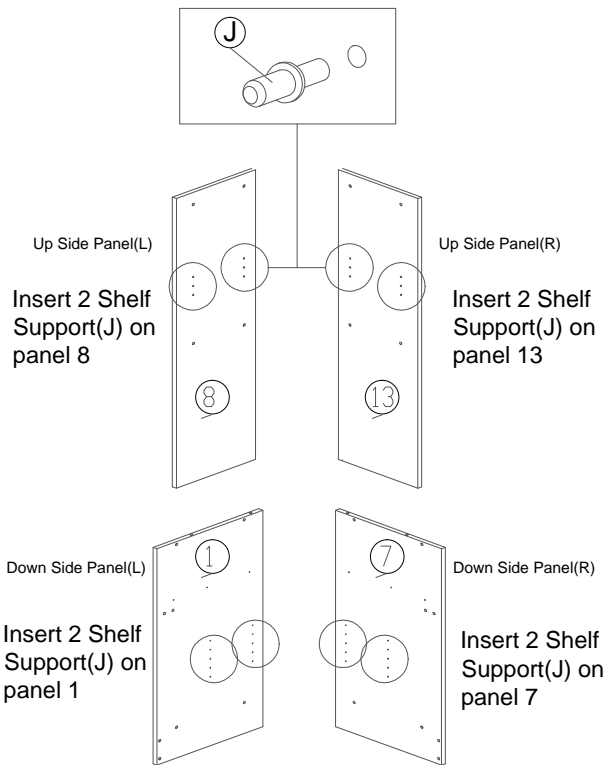
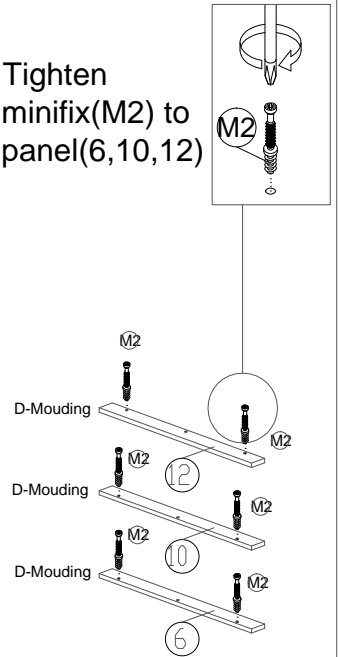

Place the drawer slide on to 2 holes area shown at Left Down side panel 1. Then tighten it with 3 screws (D).

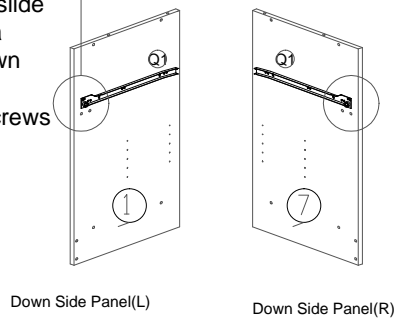
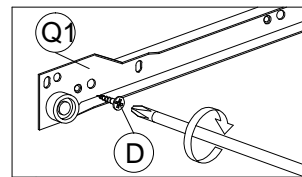

Place the drawer slide on to 2 holes area shown at Right Down side panel 7. Then tighten it with 3 screws (D).

Pre - Assembly

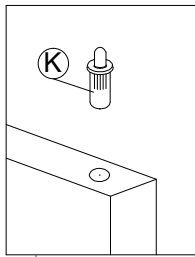

Insert door spring support(K) to both end of glass door panel(25,26) and door panel(23,24).

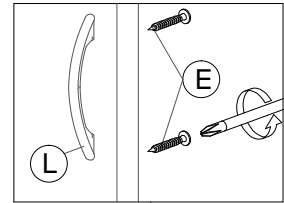
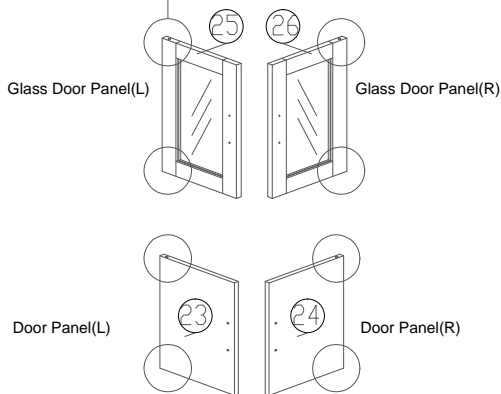

Tighten 2 screws(E) from Door Panel (23,24,25,26) into the handle (L) hole.

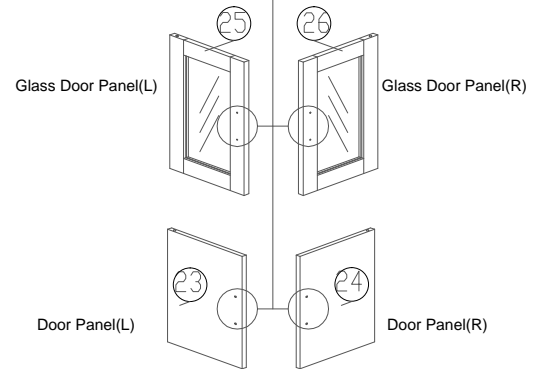

Fix and tighten metal piece(N1) with screw (C) at glass door panel (25,26) and Door panel (23,24) as shown.

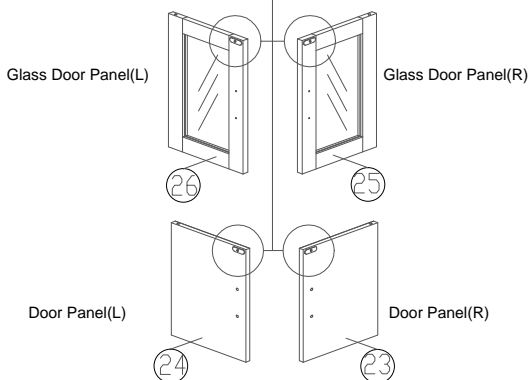
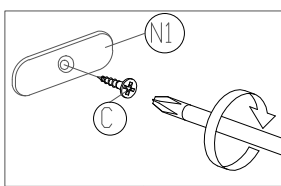

Insert magnet (N2) onto panel (2,11)'s non-thru holes as shown, make sure the magnets, iron side facing forward to edging direction.

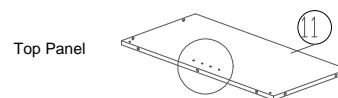
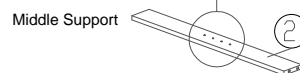
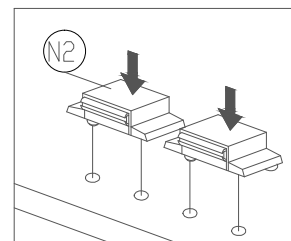

BOTTOM VIEW

Pre - Assembly

DRAWER 19

(1)

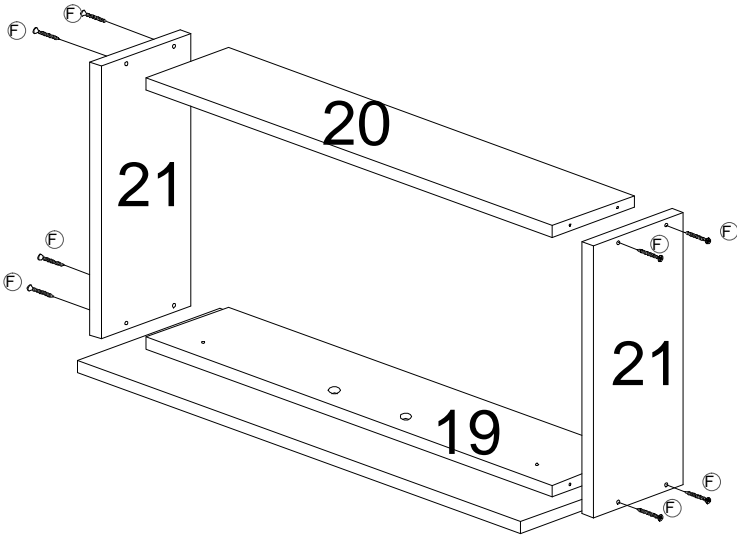

- Place 2 panel 21 on each side of panel 19 as shown
- Then, tighten screw (F) to panel 21 lower thru holes to fix them onto panel 19
- Next tighten screw (F) to panel 21 upper thru holes to fix up to the panel 20

-Flip drawer with bottom side up, place panel 22 onto the drawer and align properly. Then nail the nails provided with hammer on the border of panel 22 as shown. The gap between 2 nails is about 100mm.

-After that, place a drawer slide Q2 with the small white roller facing outward and with other end tip touching panel 19 onto each bottom side (angle) edge of panel 21 and panel 21. Then tighten 3 screws (D) on each drawer slide Q2 (as shown).

(2)

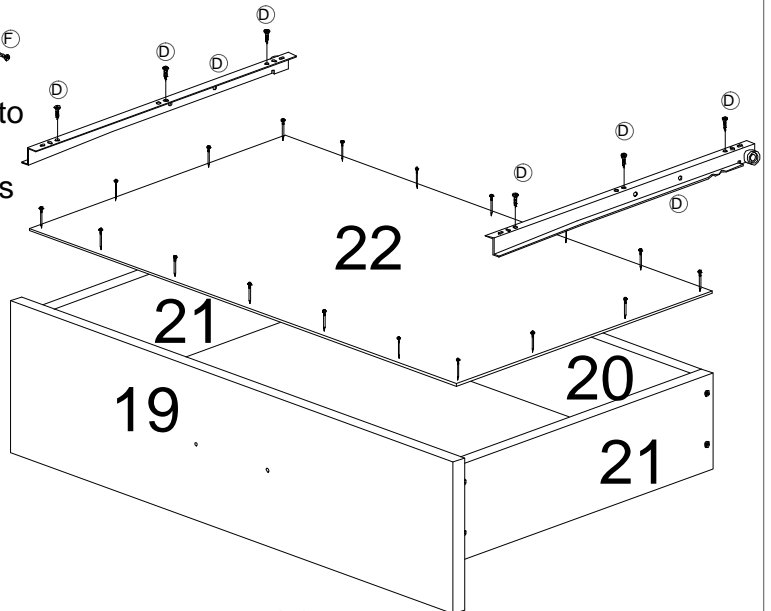

(3)

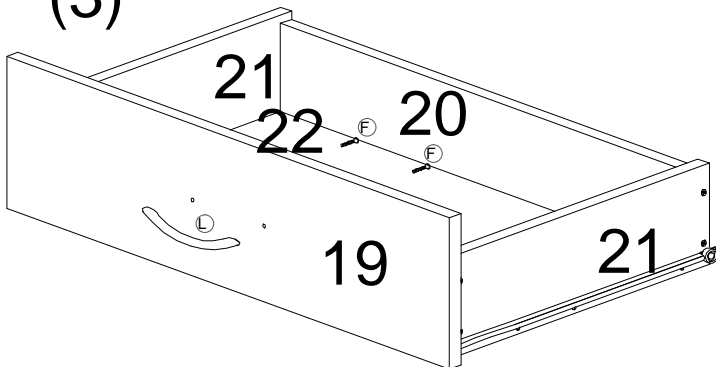

-Tighten 2 screw (F) from inner side of panel 19 into the handle (L) holes.

(4)

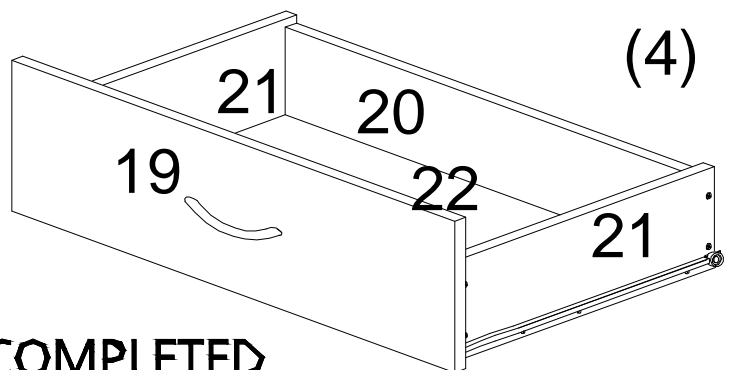

COMPLETED

Assembly Instruction Step1

Fix Panel (2,3,4) onto panel (1) by inserting dowels(A) onto non-thru at panel (1) use allen key (I) to tighten screws (G) from the thru-holes of panel (1) and after that insert minifix cap (H).

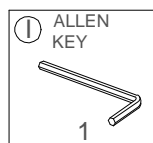
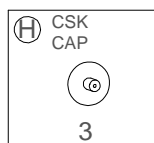
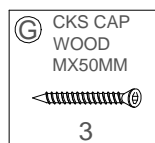
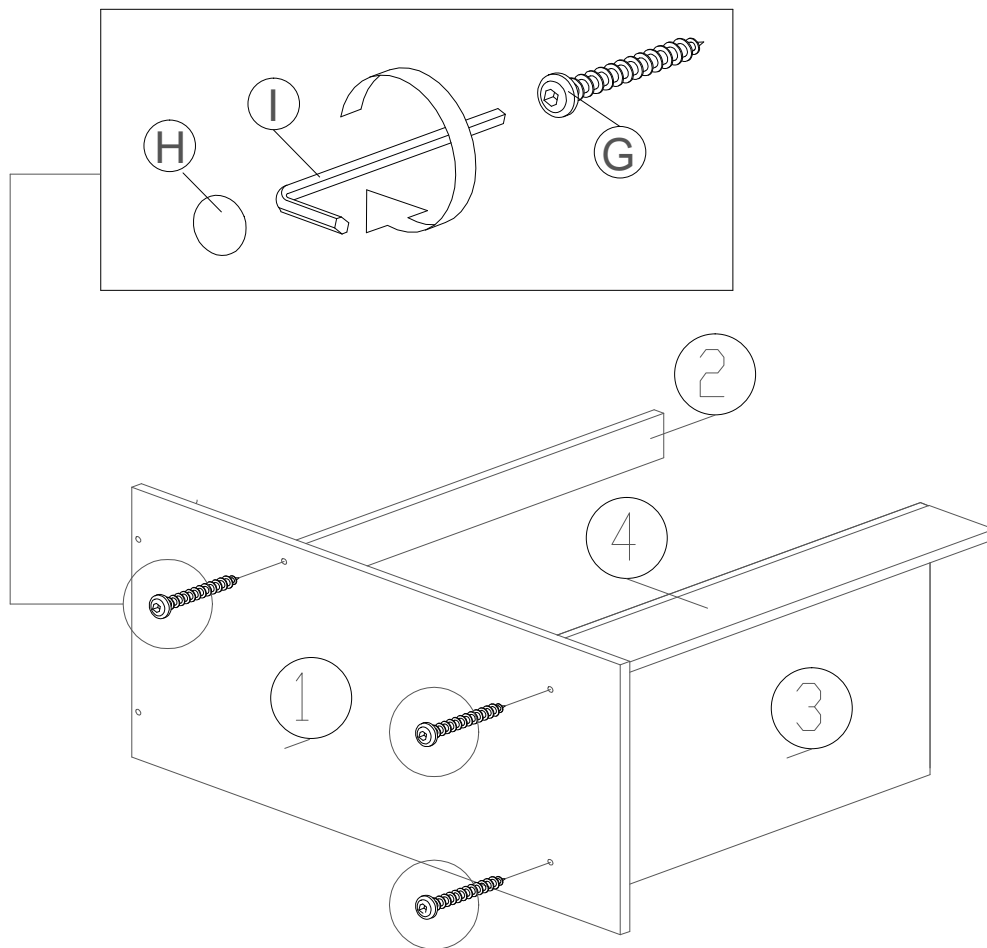

Assembly Instruction Step2

Fix Panel (5,6) onto panel (1) by inserting dowels(A) onto non-thru at panel (1) use allen key (I) to tighten screws (G) from the thru-holes of panel (1) and after that insert minifix cap (H).

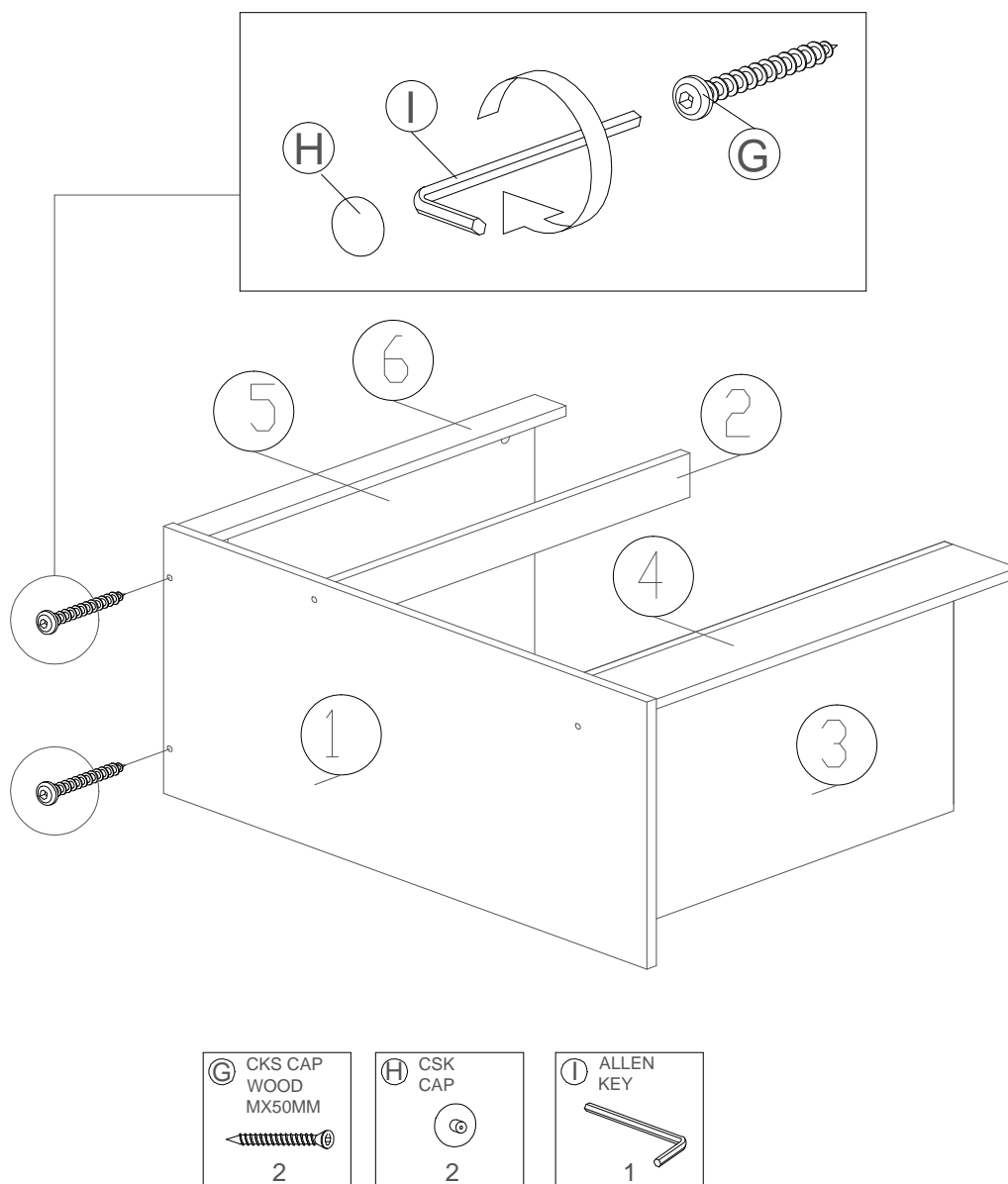

Assembly Instruction Step 3

Fix Panel (6) onto panel(5) by inserting minifix (M1) into panel (5)'s L-thru holes and using allen key (I) to tighten it after that insert minifix cap(H).

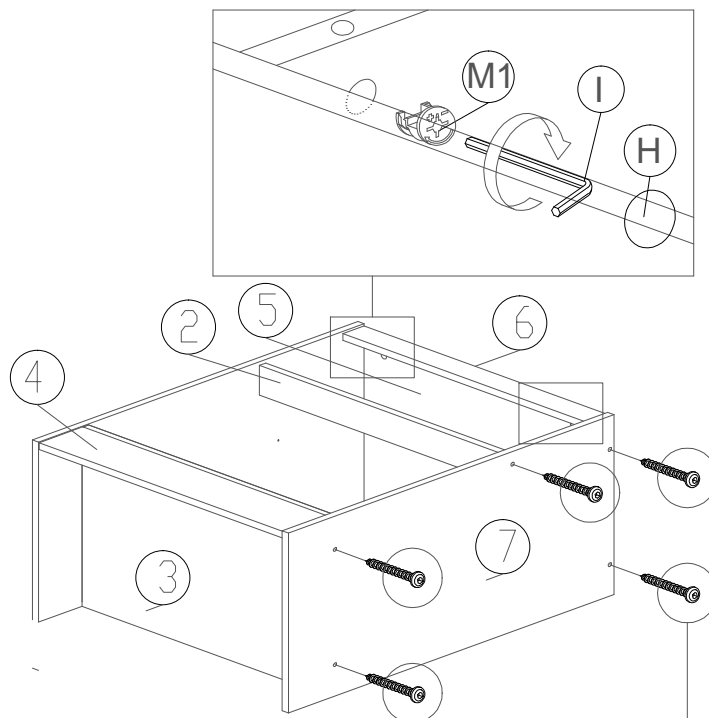

Fix Panel (2,3,4,5,6) onto panel (7) by inserting dowels(A) onto non-thru at panel (7) use allen key (I) to tighten screws (G) from the thru-holes of panel (7) and after that insert minifix cap (H).

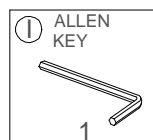
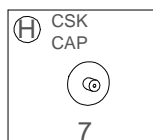
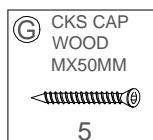
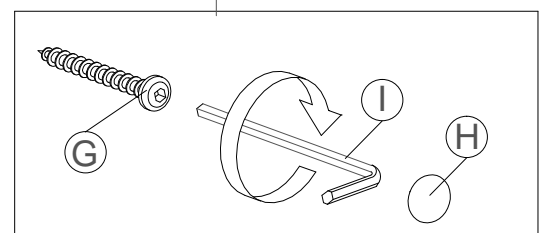

PART 1

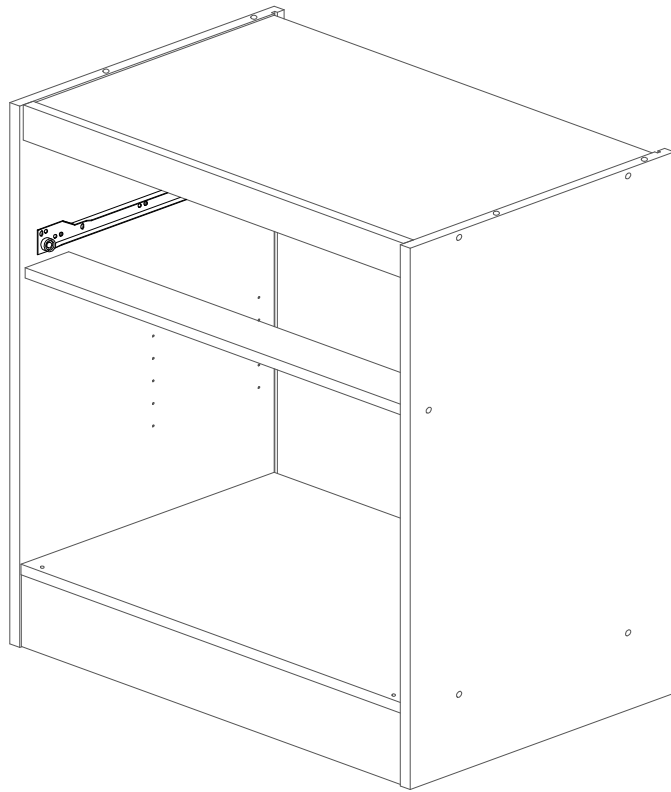

Assembly Instruction Step 4

Fix panel (9,10,11,12) onto panel (8) by inserting dowels (A) onto non-thru holes at panel (8).

Use Allen key (I) to tighten screw (G) from the thru holes of panel (8) and after that insert minifix cap (H).

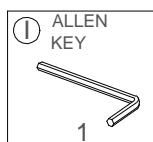
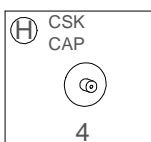
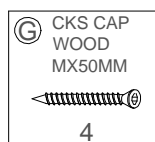
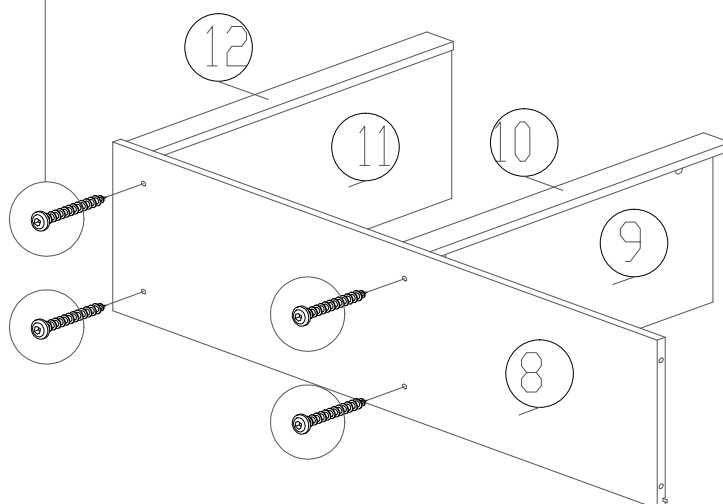
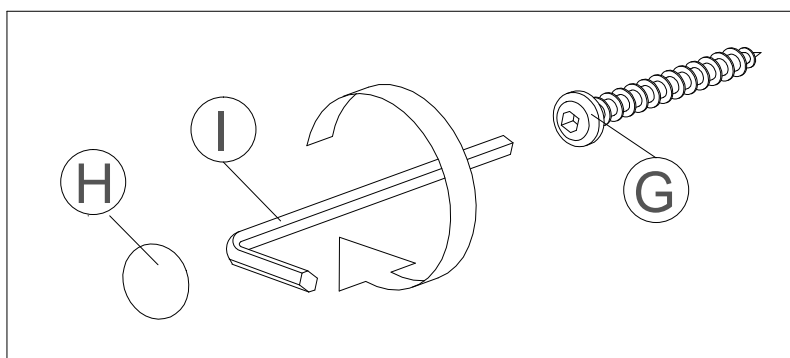

Assembly Instruction Step 5

Fix Panel (9,11) onto panel(10,12) by inserting minifix (M1) into panel (9,11)'s L-thru holes and using allen key (I) to tighten it after that insert minifix cap(H).

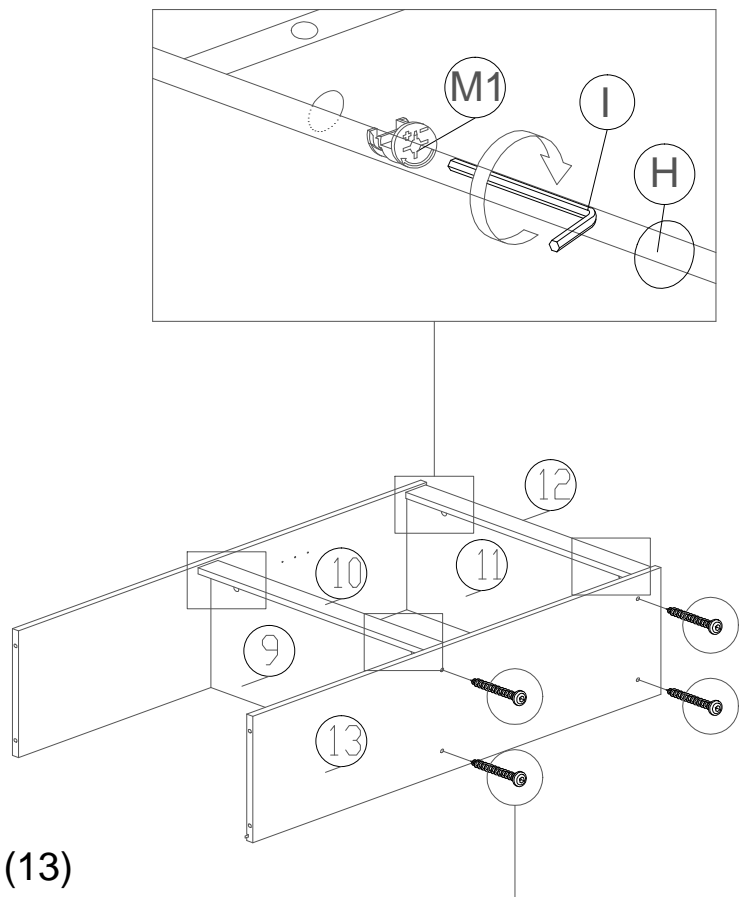

Fix Panel (9,10,11,12) onto panel (13) by inserting dowels(A) onto non-thru at panel (13) use allen key (I) to tighten screws (G) from the thru-holes of panel (13) and after that insert minifix cap (H).

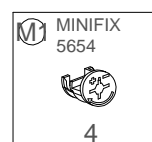
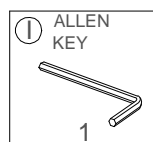
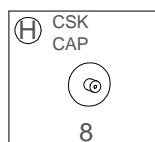
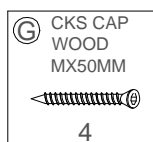
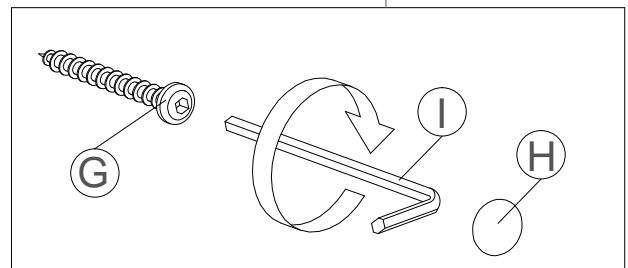

PART 2

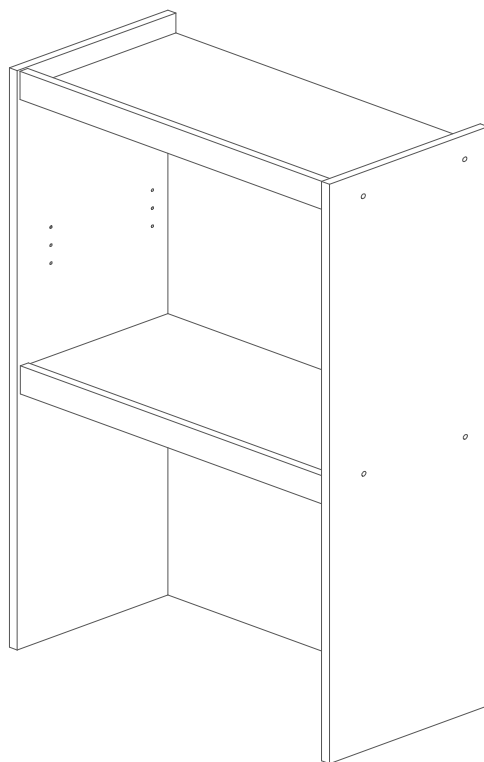

Assembly Instruction Step 6

Insert glue(P) into side panel (1,7)hole,and insert Dowel(B) using hammer to gently tap them in.

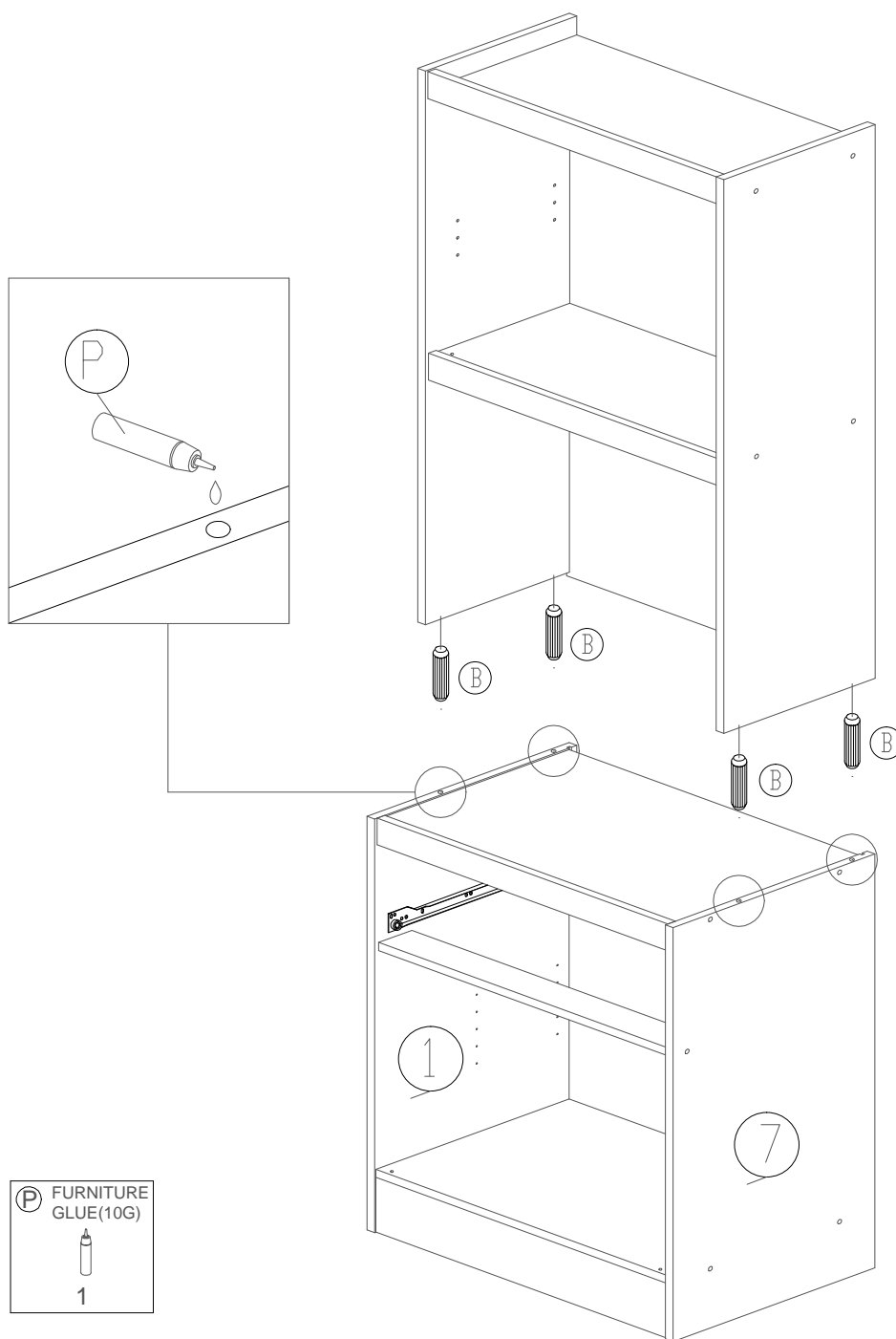

PART 2

PART 1

Assembly Instruction Step 7

At face down position ,Place back panel (14,15,16)onto the back of the main unit,and align it properly for nailing. Use hammer to nail the nails one by one on the line drawn and at center of 4side edges.Gap between 2 nails should be about 100mm for all.

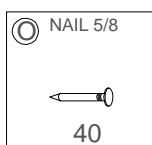
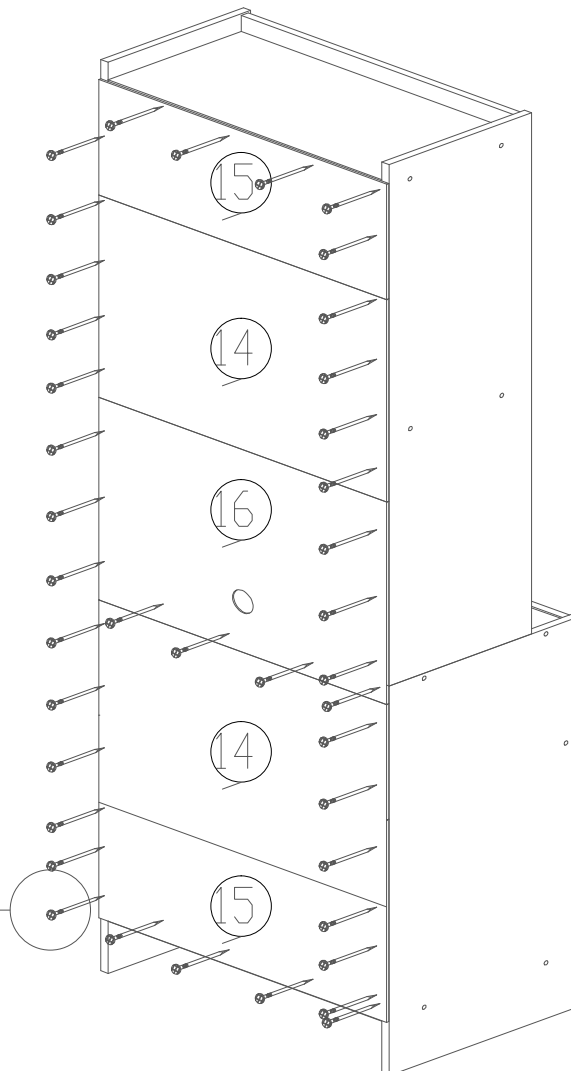
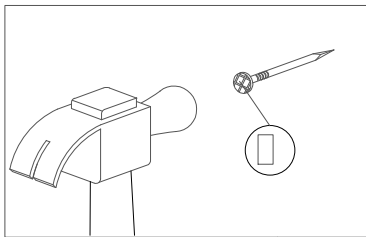

Assembly Instruction Step 8

Take panel (18) and place it inside the top compartment by putting it on the 4 shelf support as shown.

Put in the drawer by slotting the rollers at each end of drawer slide (Q2) onto the rail of drawer slide (Q1) fixed at side panel 1 and 7. Then push the drawer in slowly. Then take the movable shelf 17 and place it inside the lower compartment by putting it on top the 4 shelf support.

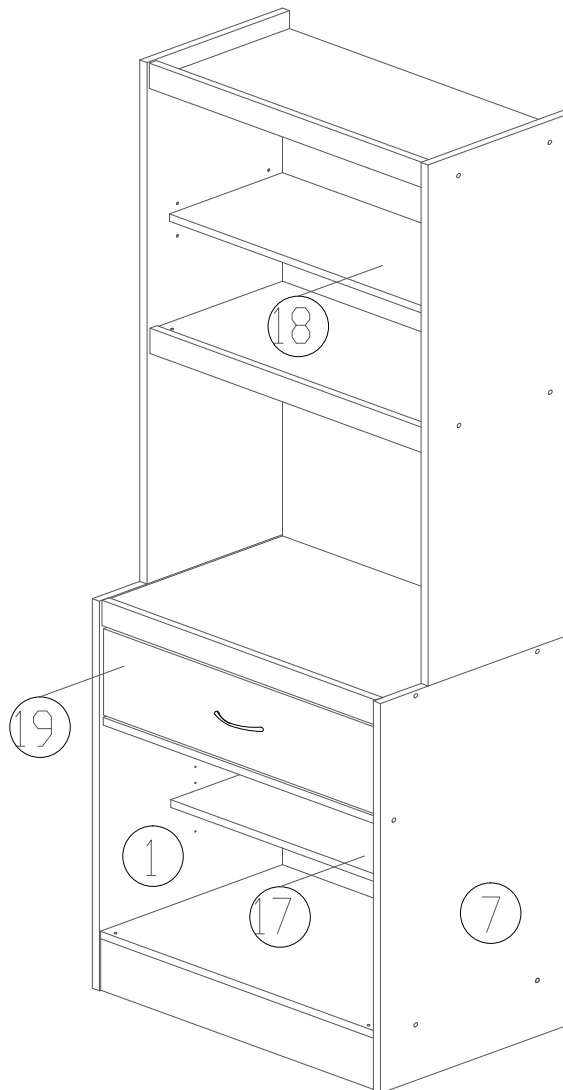

Assembly Instruction Step 9

Fix upper Glass Panel (25,26) by pushing and slotting the door support (K) onto each holes at bottom of panel (9) and top of panel (11)

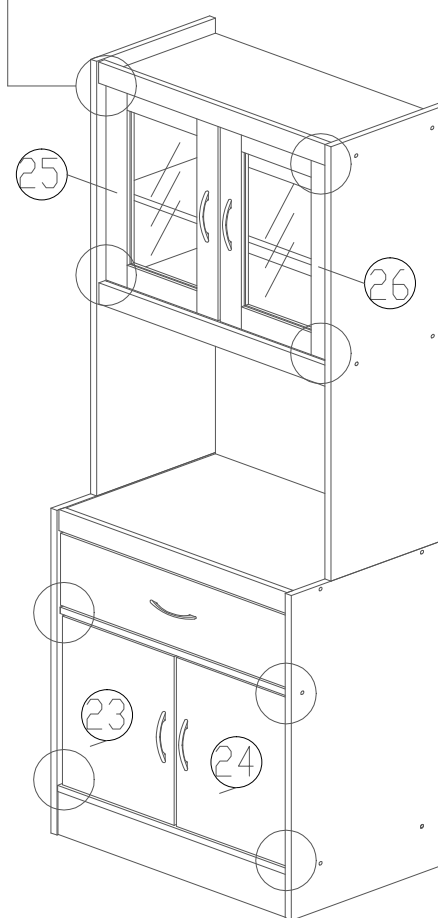
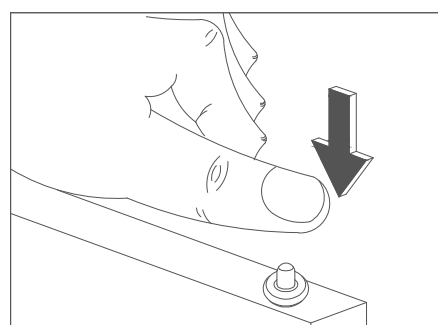

Fix down door panel (23,24) by pushing and slotting the door support (K) onto each holes at bottom of panel (3) and top panel (2).

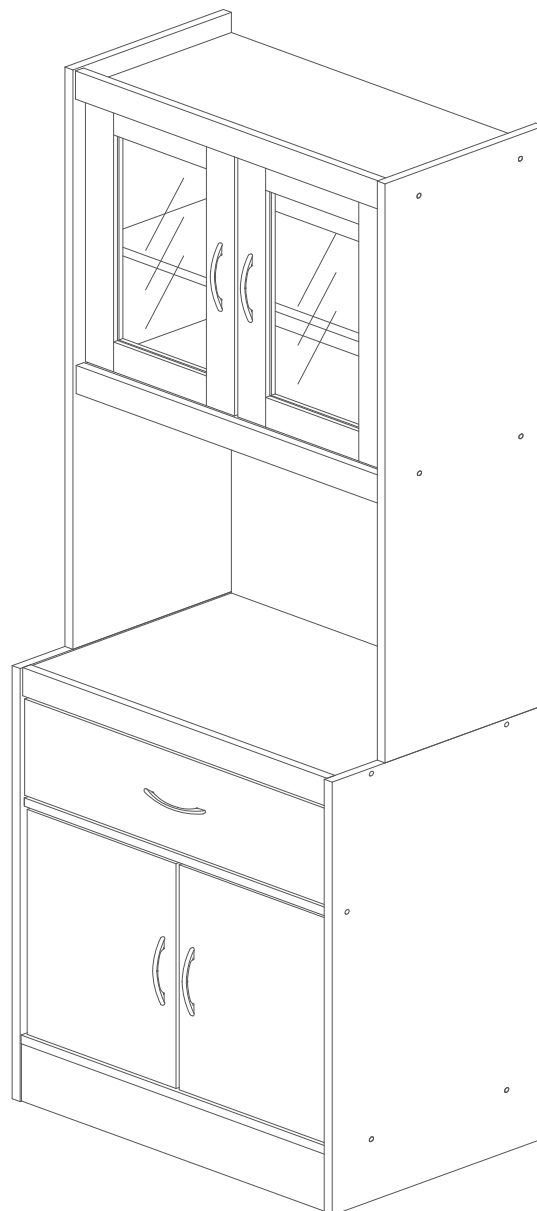

Completion

In the interest of our environment please dispose of all packaging thoughtfully.