

**Assembly Instructions**  
***Instructions de montage***  
***Instrucciones de armado***

**6 Drawer Dresser**  
***Commode à six tiroirs***  
***Comoda seis cajones***

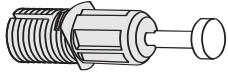

**Dresser Hardware / Quincaillerie de Commode / Piezas de Comoda**



Blue Rapid Rod (6)  
Tige rapide bleu  
Clavija azul de ajuste rápido

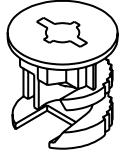

Large Zinc Cam (16)  
Ferrure en zinc grand  
Tuercas de fijación grande de zinc

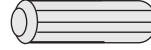

Wood Dowel (4)  
Goujons de bois  
Clavija de madera

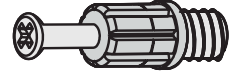

Green Twister Dowel (10)  
Goujon de torsion vert  
Clavija verde giratoria

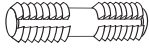

Plastic Dowel (6)  
Goujon en plastique  
Clavija de plastico

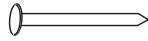

3/4" Nail (36)  
Clou 3/4"  
Clavo de 3/4 pulg.



Drawer Slide Screw (48)  
Vis pour coulisse de tiroir  
Tornillos para rieles de cajón

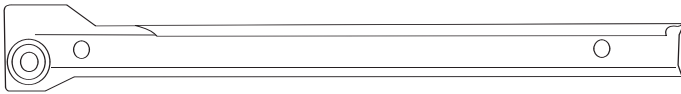

1 LEFT Cabinet Slide per Drawer (Total = 6)  
Glissière GAUCHE De Cabinet (total = 6)  
1 riel de gabinete izquierdo por cajón (total = 6)

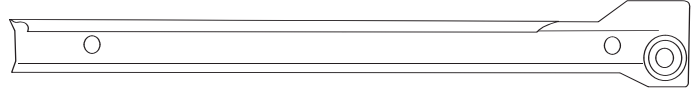

1 RIGHT Cabinet Slide per Drawer (Total = 6)  
Glissière DROITE De Cabinet (total = 6)  
1 riel de gabinete derecho por cajón (total = 6)

**Drawer Hardware / Quincaillerie de tiroir / Piezas de los cajones**

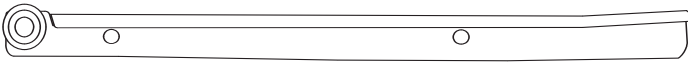

1 LEFT Drawer Slide per Drawer (Total = 6)  
1 Glissière GAUCHE de tiroir par tiroir (total = 6)  
1 riel de cajón IZQUIERDO por cajón (total = 6)



1 RIGHT Drawer Slide per Drawer (Total = 6)  
1 Glissière DROITE de tiroir par tiroir (total = 6)  
1 riel de cajón DERECHO por cajón (total = 6)

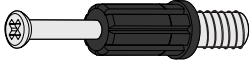

Black / noir / negro Twister Dowel (24)  
Goujon de torsion noir  
Clavija negro giratoria

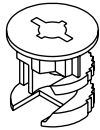

Small Zinc Cam (24)  
Petite ferrure en zinc  
Tuercas de fijación pequeña de zinc



#8 - 1 1/2" Screws (24)  
Vis no. 8 - 1 1/2 po.  
Tornillo de 1 1/2"

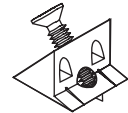

Drawer Bottom Stabilizer (12)  
Stabilisateur inférieur de tiroir  
Estabilizador inferior de cajón

#8-32mm Machine Screw (6)  
Vis de machne de 32mm  
Tornillo para máquina de 32mm pulg.



Knob (6) for black  
Poignée pour noir  
Perilla por negro

for white  
pour blanc  
por blanco

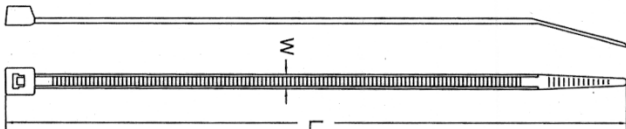
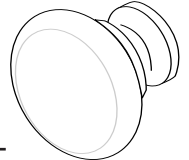

Cable Tie (1) / Attache pour cable / sujetador de cable



Mounting Base (2)  
Base de support  
Base de montaje



#6 - 3/4 Pan Head Screw (1)  
Vis #6-3/4 po.  
torillo núm. 6 de 3/4 de pulg.

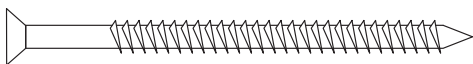

3 1/2" Wood Screw (1)  
Vis à bois 3 1/2 pouces  
Tornillo para madera de 3 1/2 pulgadas

**Dresser Parts**  
**Pièces de la commode**  
**Piezas de Comoda**

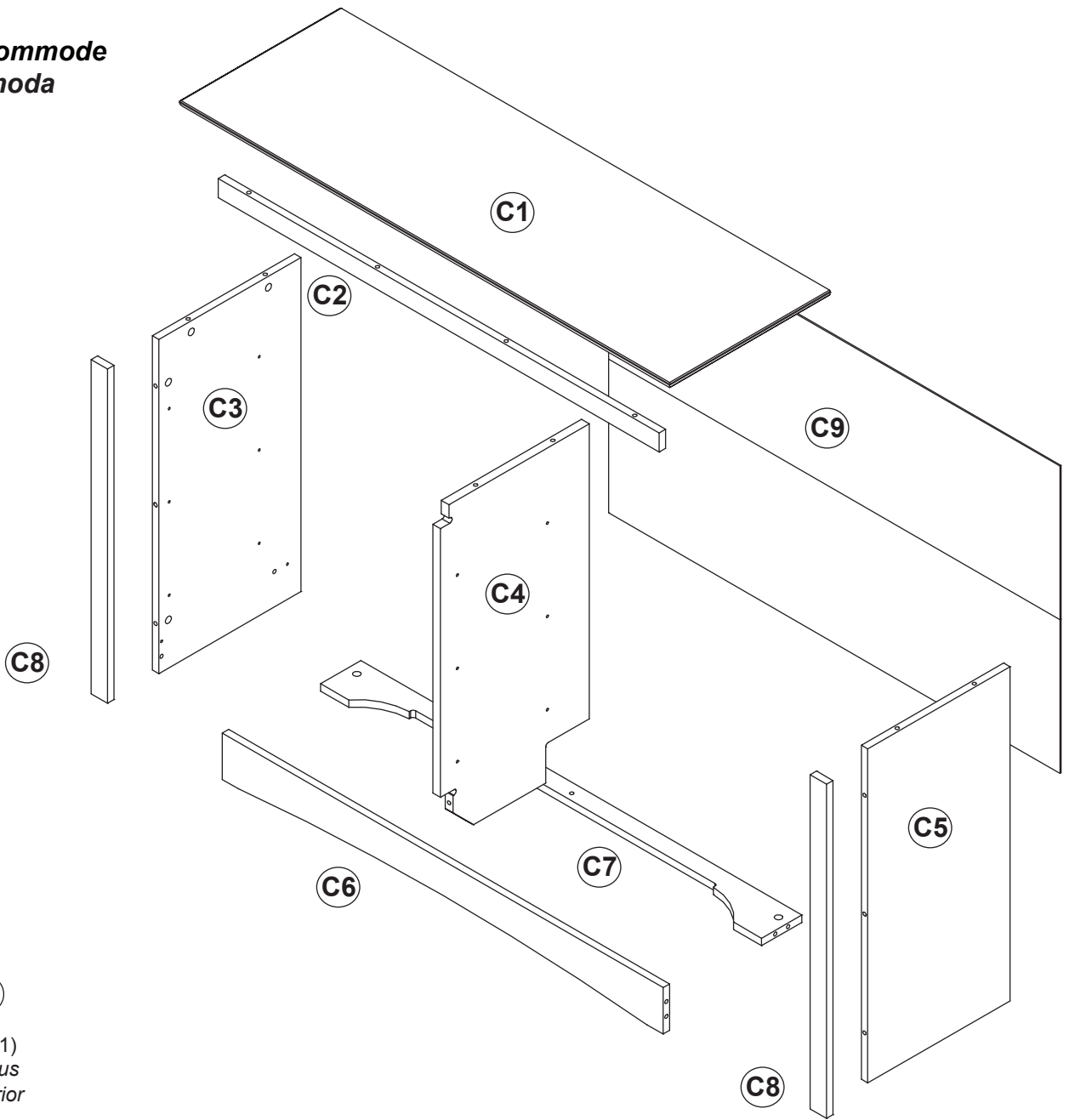

**C1**

Top (1)  
*Dessus*  
*Superior*

black / noir / negro

white / blanc / blanco

**C2**

Top Moulding (1)  
*Moulure supérieure*  
*Moldura superior*

black / noir / negro

white / blanc / blanco

**C3**

Left Side (1)  
*Côté gauche*  
*Lado izquierdo*

black / noir / negro

white / blanc / blanco

**C4**

Center Gable (1)  
*Pignon central*  
*Separador central*

black / noir / negro

white / blanc / blanco

**C5**

Right Side (1)  
*Côté droit*  
*Lado derecho*

black / noir / negro

white / blanc / blanco

**C6**

Decorative Stabilizer A (1)  
*Stabilisateur décoratifs A*  
*Estabilizador decorativo A*

black / noir / negro

white / blanc / blanco

**C7**

Decorative Stabilizer B (1)  
*Stabilisateur décoratifs B*  
*Estabilizador decorativo B*

black / noir / negro

white / blanc / blanco

**C8**

Side Moulding (2)  
*Moulure latérale*  
*Moldura lateral*

black / noir / negro

white / blanc / blanco

**C9**

Backer (1)  
*Dos*  
*Respaldo*

unfinished /  
*non-fini / s*  
*in acabado*

**Required Tools /  
Outils requis /  
Herramientas necesarias**

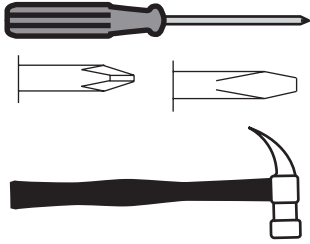

**Optional Tools:**  
Using a power screwdriver  
will speed up assembly.

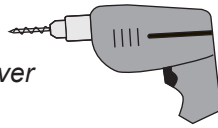

**Outils facultatifs**  
Utilisant la puissance un tournevis  
accélérera l'assemblée.

**Herramientas opcionales:**  
El montaje será más rápido con un  
destornillador eléctrico.

**Caution**

Do not over tighten any screw. The last few turns of each screw should be done very slowly or by hand.

**Attention**

Évitez de trop serrer les vis. Ralentissez la vitesse de la foreuse pour les derniers deux tours de vis ou vissez-les lentement à la main.

**Precaución**

No apriete los tornillos demasiado. Las últimas vueltas de cada tornillo deben hacerse muy lentamente o con la mano.

**BEFORE YOU BEGIN**  
Identify ALL parts and hardware to  
ensure everything is included.

**AVANT DE COMMENCER**  
Identifier toutes les pièces et le matériel  
afin de s'assurer que tout est inclus.

**ANTES DE COMENZAR**  
Identifique todos las partes y componentes  
para estar seguro que todo está incluido

**1**

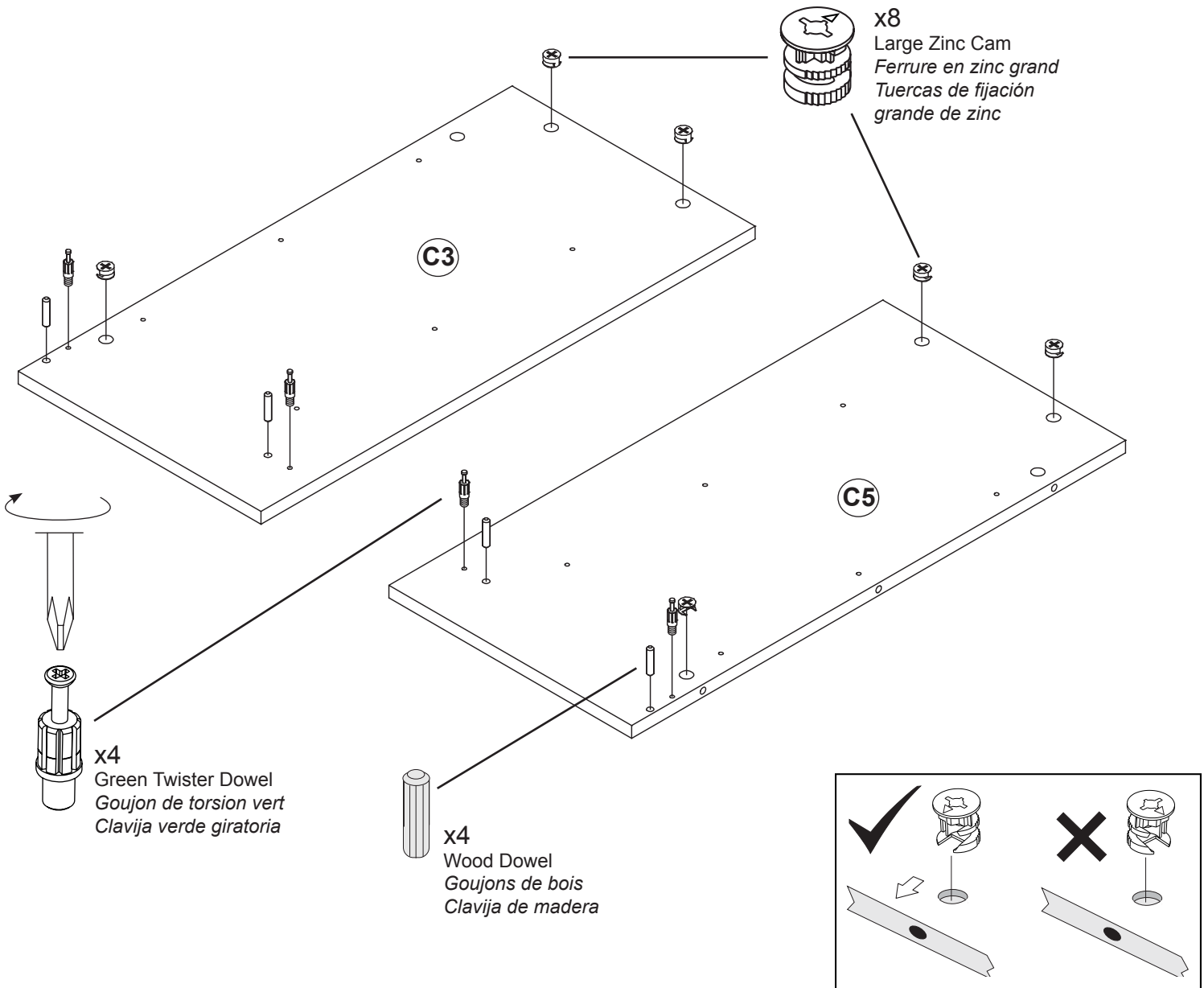

**2**

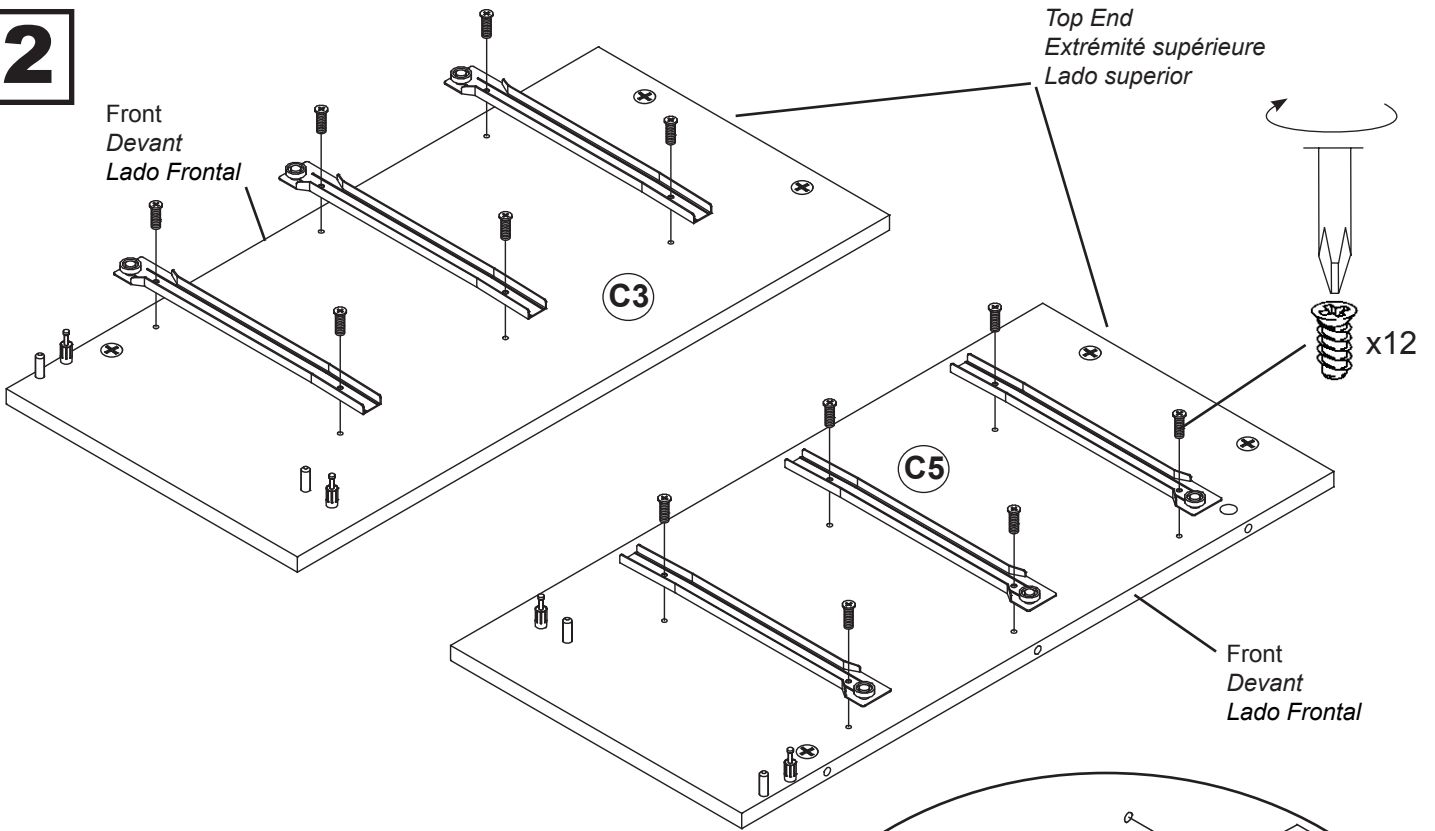

**3**

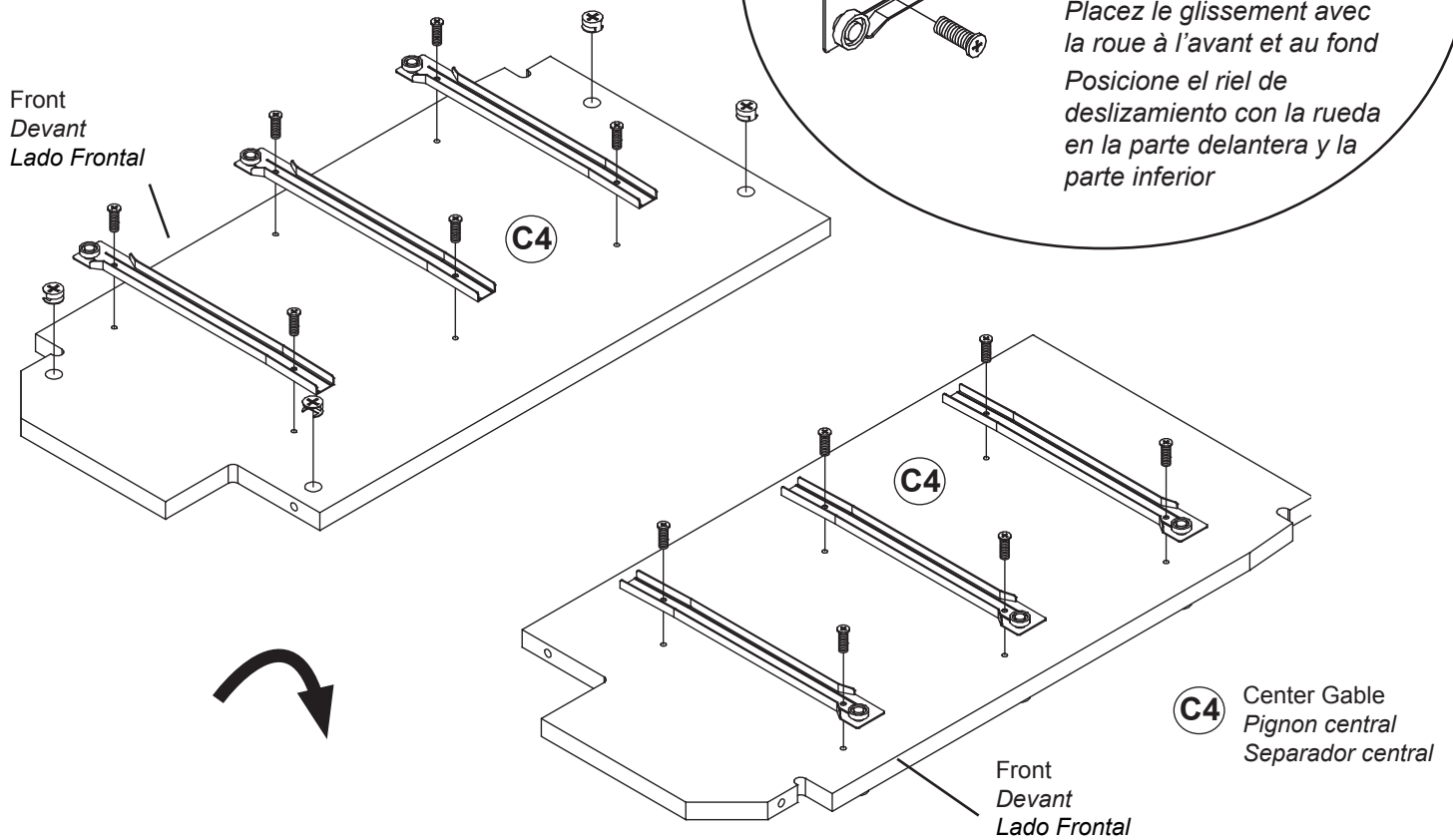

**4**

Decorative stabilizers A (C6) and B (C7) are interchangeable. Choose the style that you prefer and attach it to the front. Attach the remaining stabilizer at the rear.

*Stabilisateurs décoratifs A (C6) et B (C7) sont interchangeables. Choisissez le style que vous préférez et l'attachez à l'avant. Fixez le stabilisateur restant à l'arrière.*

*Los estabilizadores decorativos A (C6) y B (C7) son intercambiables. Elija el estilo que prefiera y fíjelo en la parte frontal. Fije el otro estabilizador en la parte posterior.*

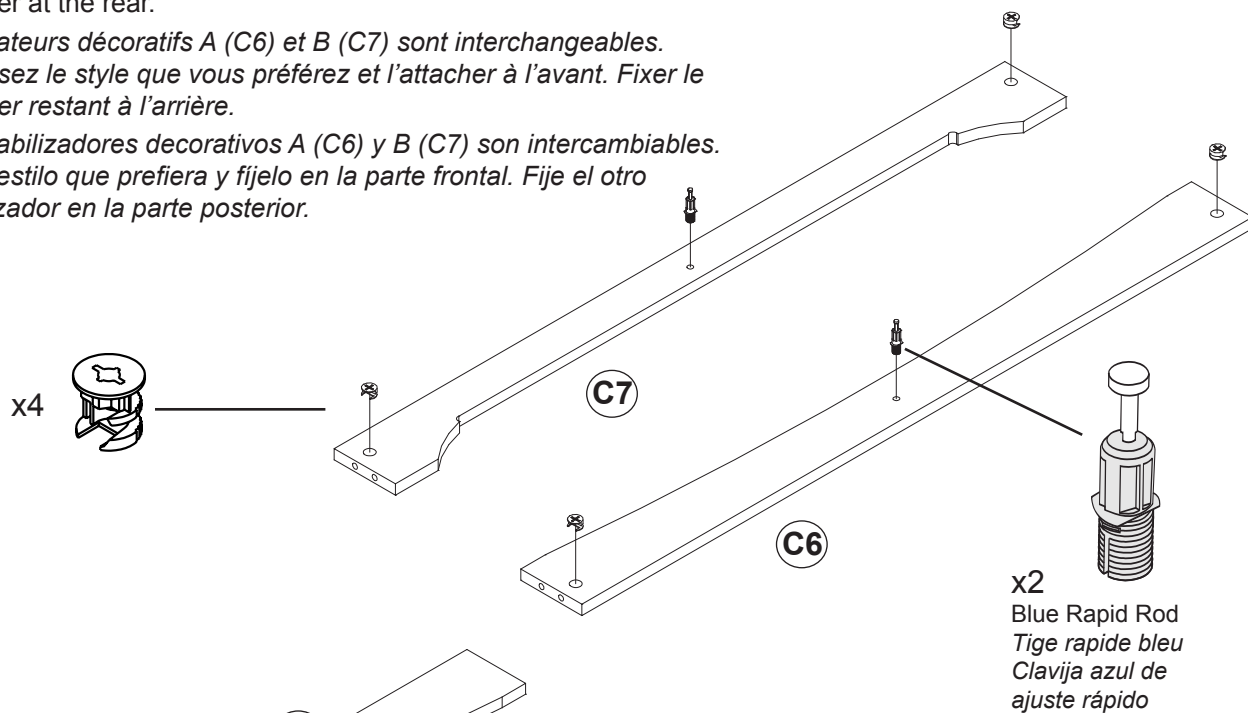

**5**

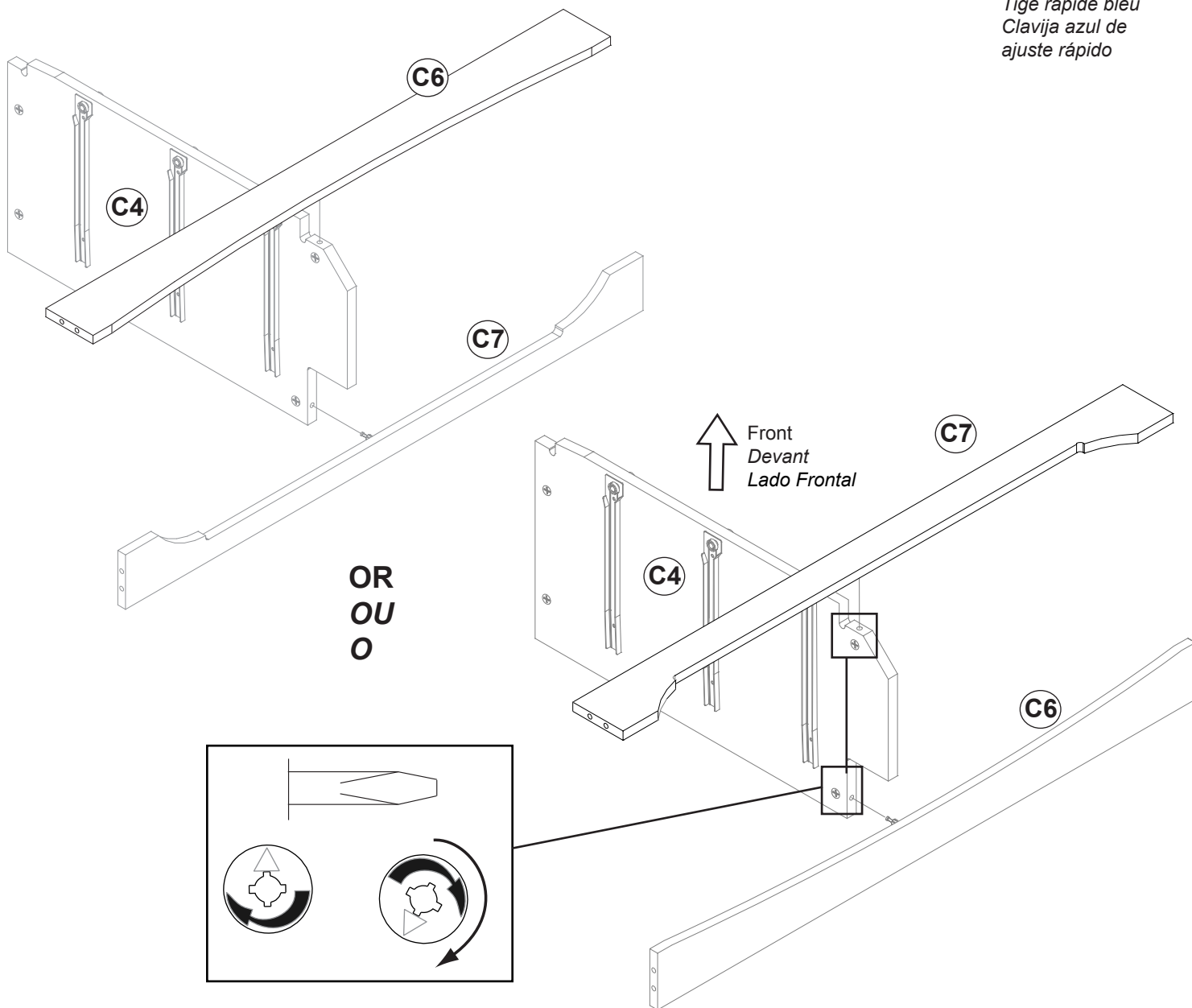

**6**

These instructions show Decorative Stabilizer A (C6) visible at the front  
*Ces instructions montrent le Stabilisateur Décoratif A (C6) visible à l'avant*  
*Estas instrucciones muestran el estabilizador decorativo A (C6) visible en la parte frontal*

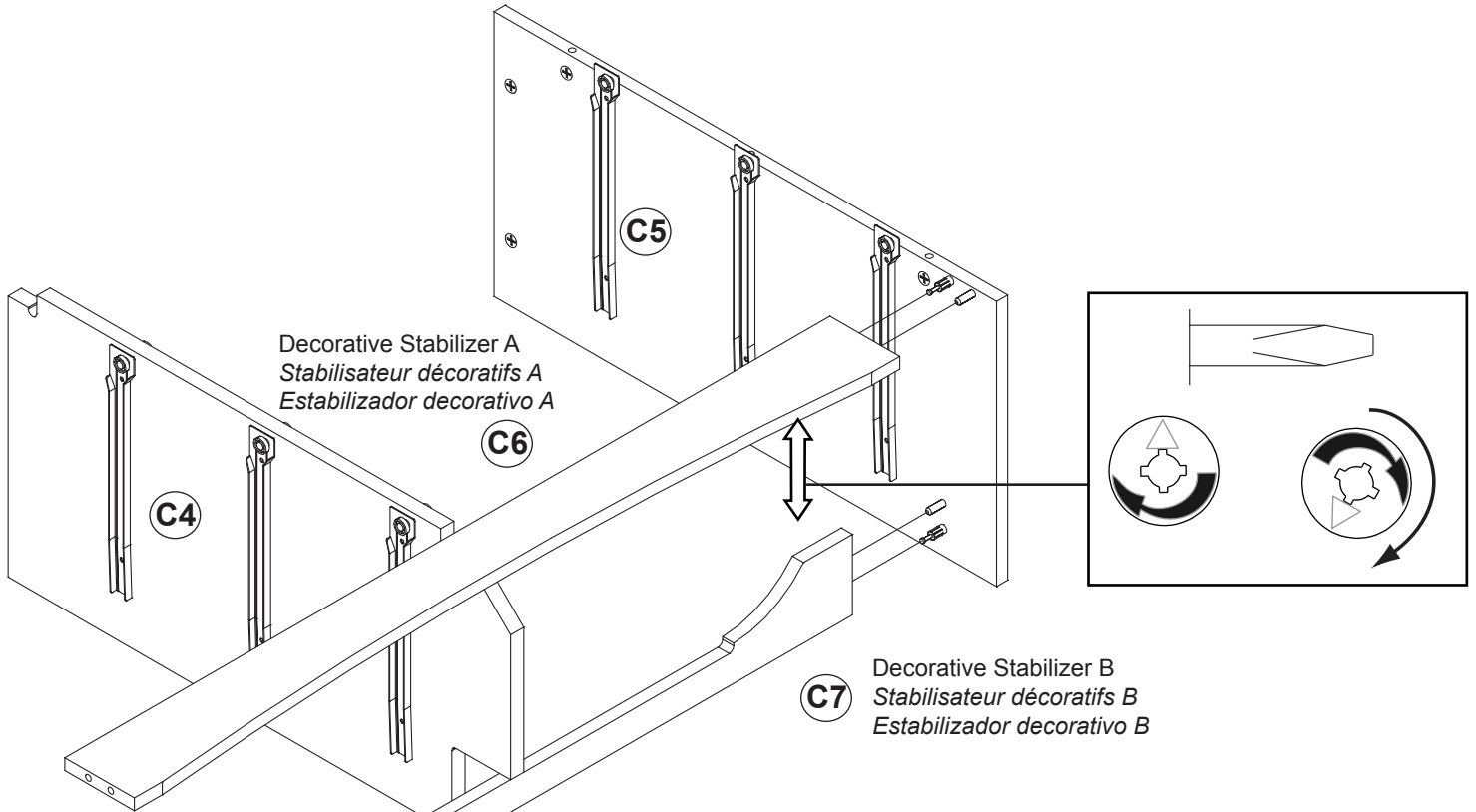

**7**

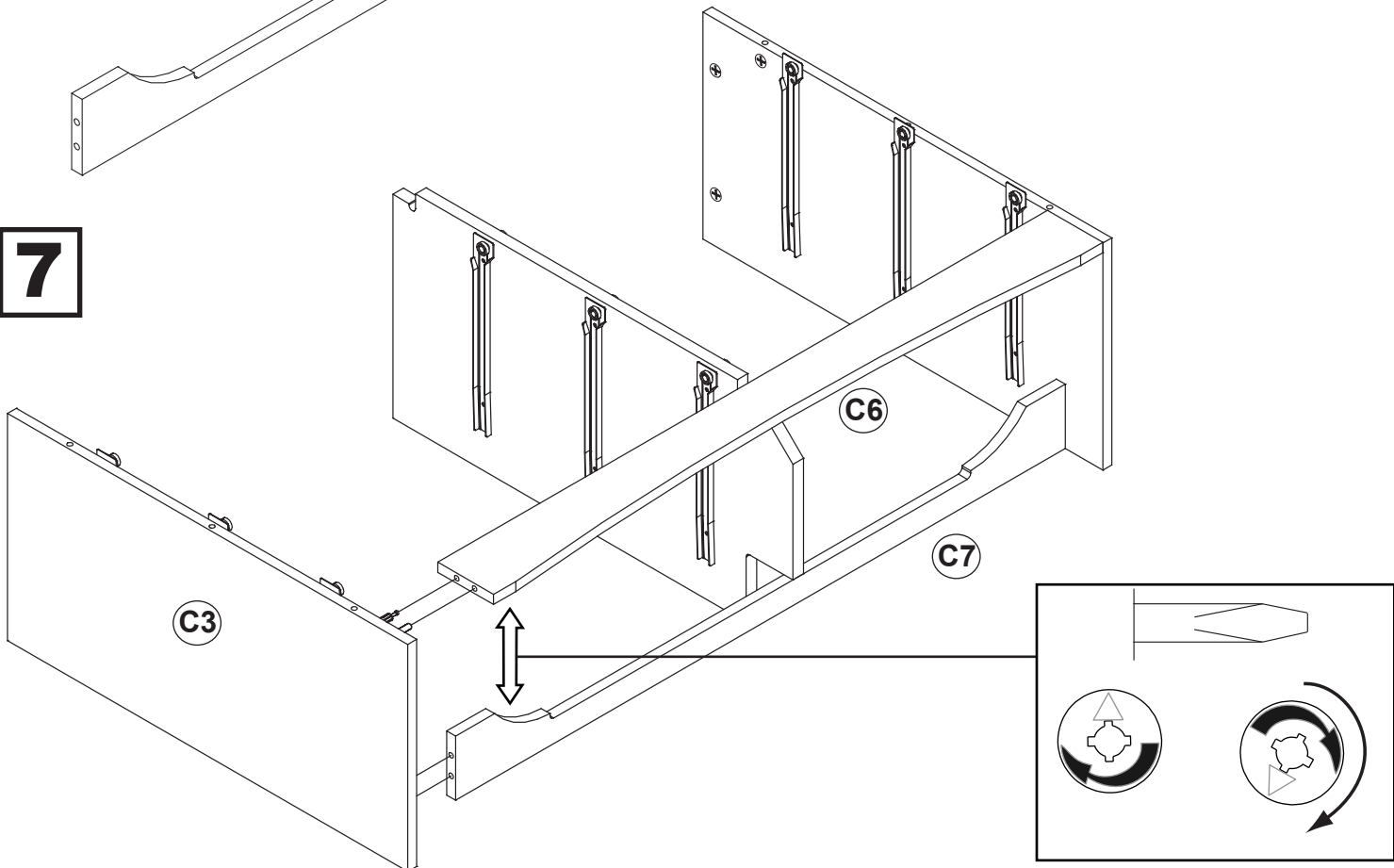

**8**

x4  
Blue Rapid Rod  
*Tige rapide bleu*  
*Clavija azul de ajuste rápido*

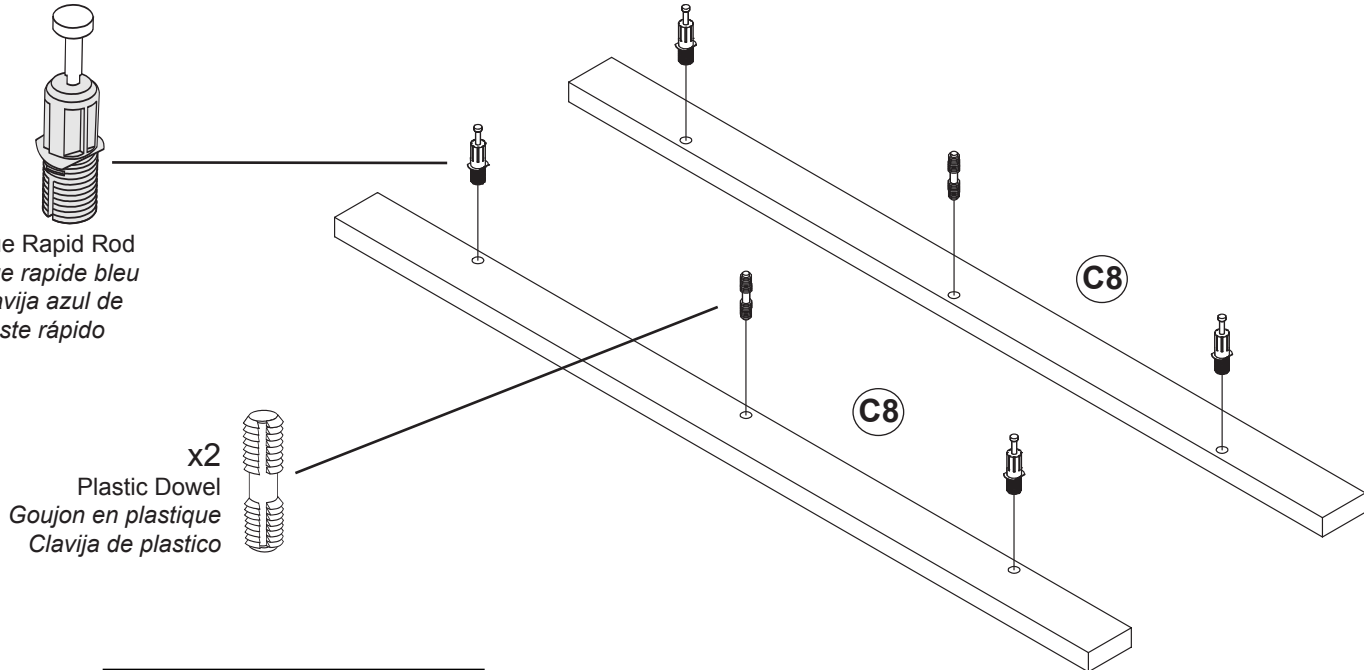

x2  
Plastic Dowel  
*Goujon en plastique*  
*Clavija de plastico*

**9**

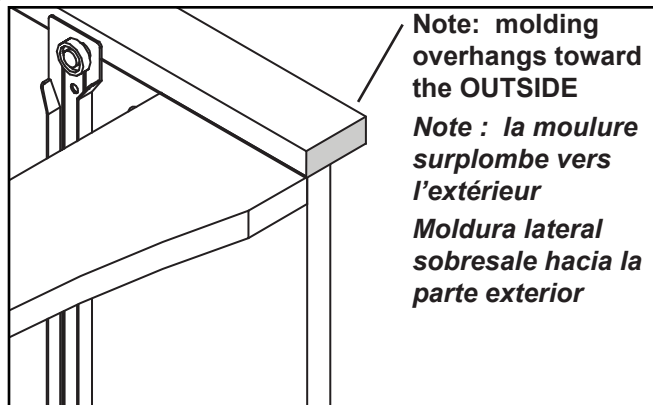
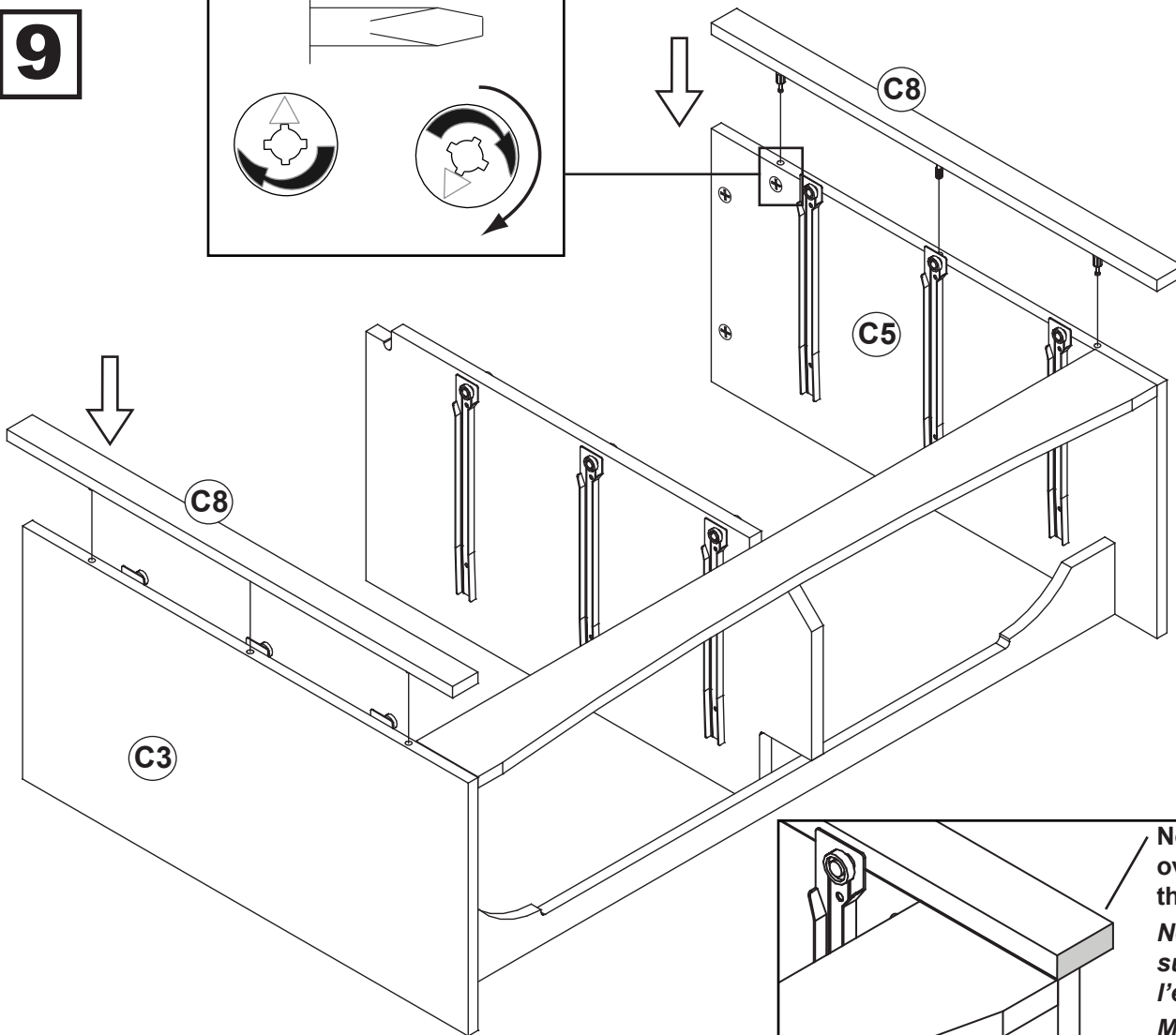
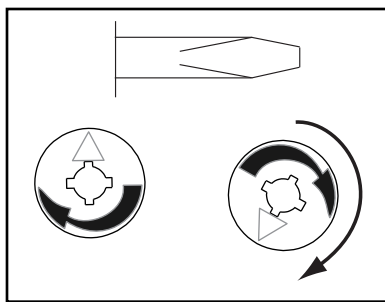



**10**

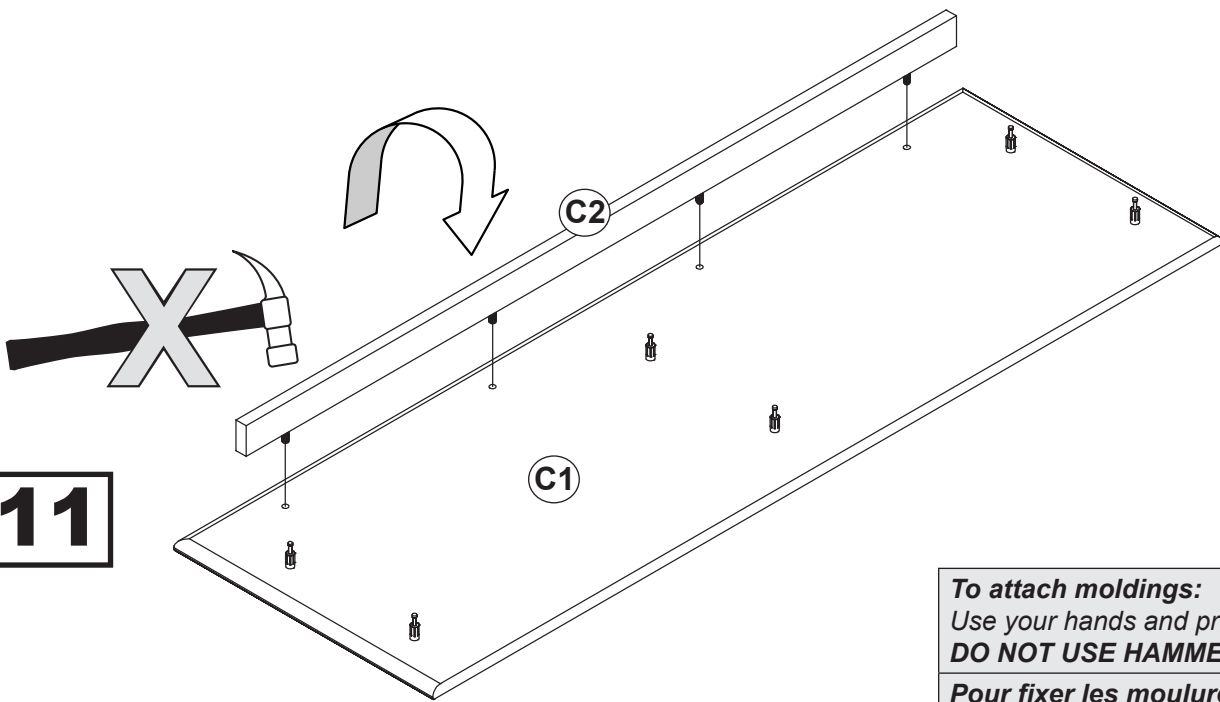
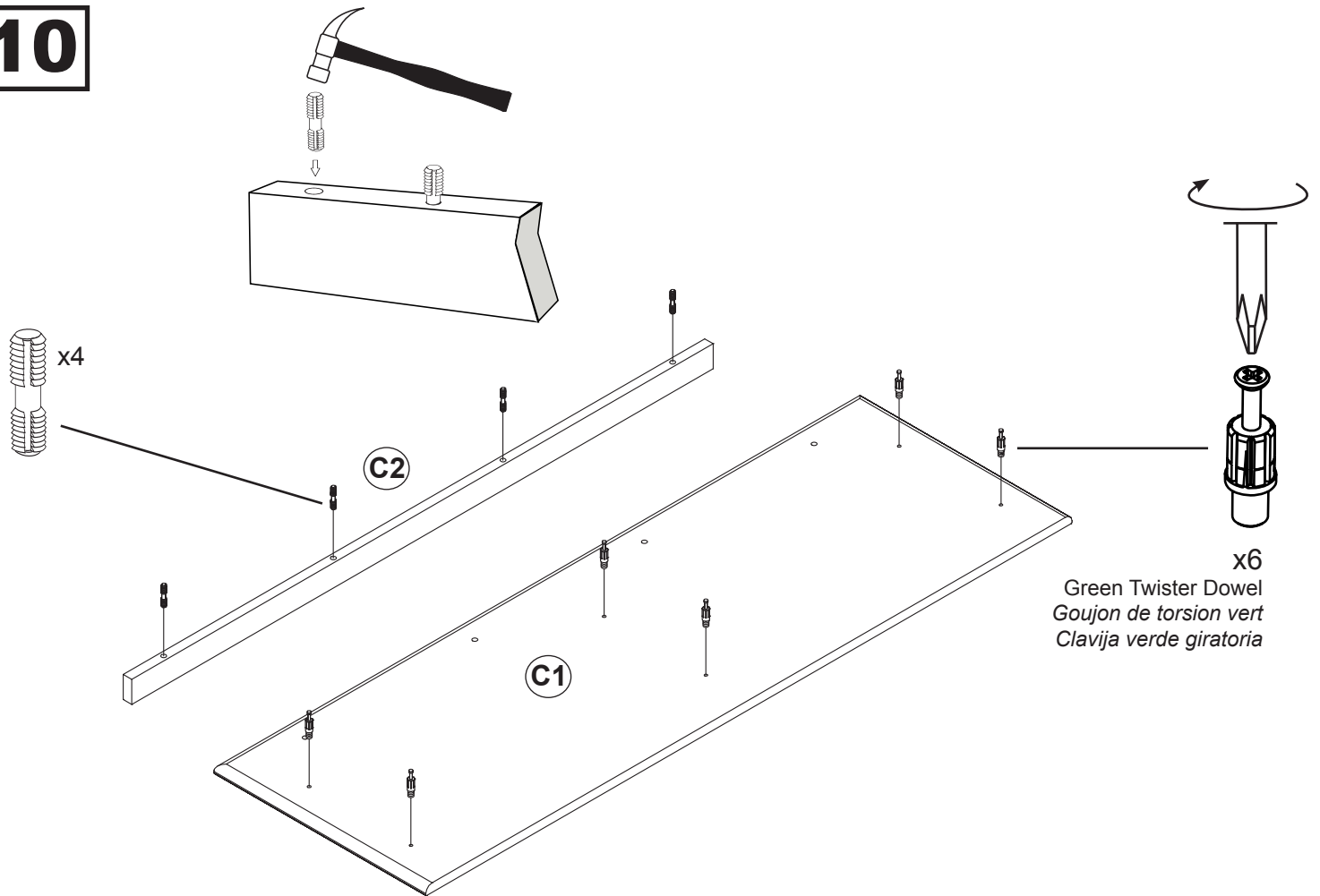

**11**

**To attach moldings:**  
Use your hands and press firmly  
**DO NOT USE HAMMER**

**Pour fixer les moulures :**  
Utilisez vos mains et appuyez fermement  
**NE PAS UTILISER DE MARTEAU**

**Para colocar las molduras:**  
Use sus manos y presione firmemente  
**NO USE EL MARTILLO**

**12**

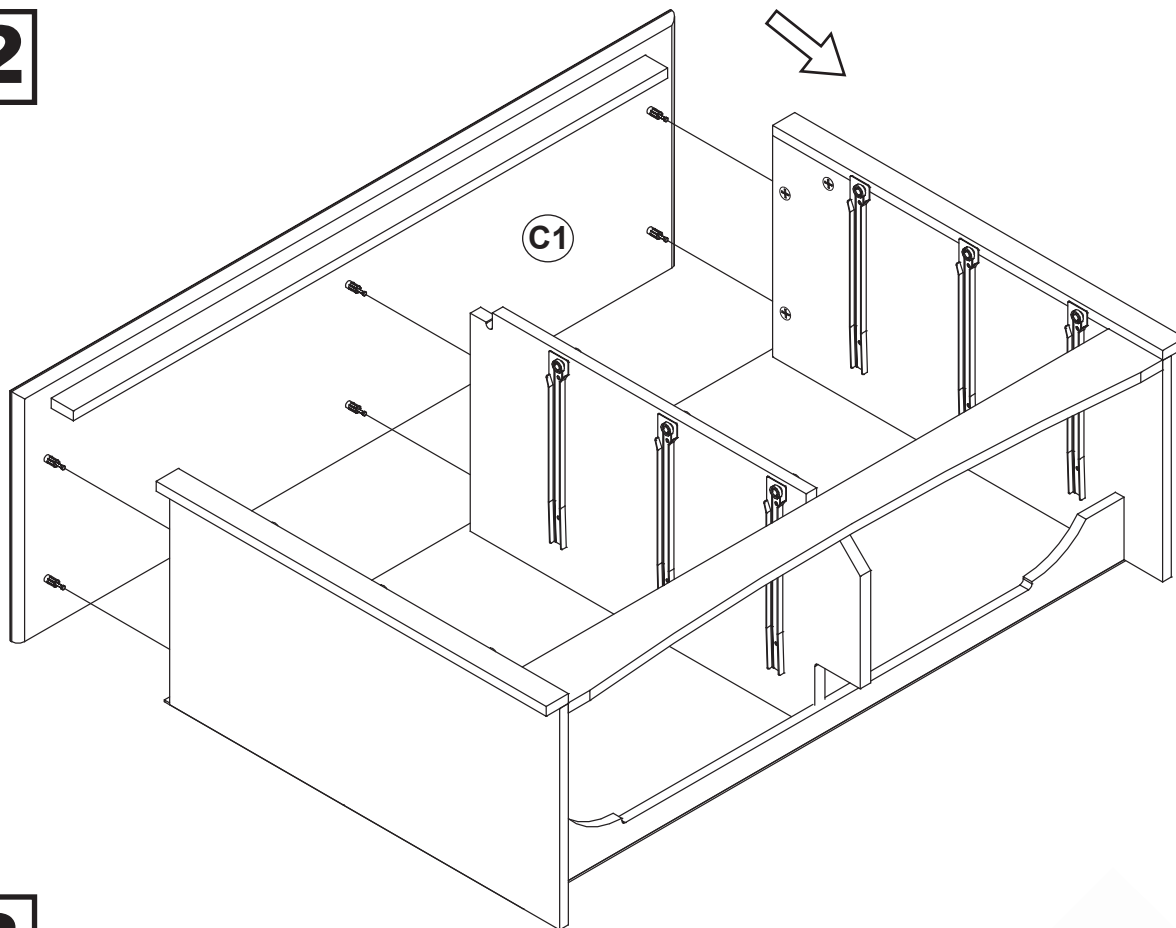

**13**

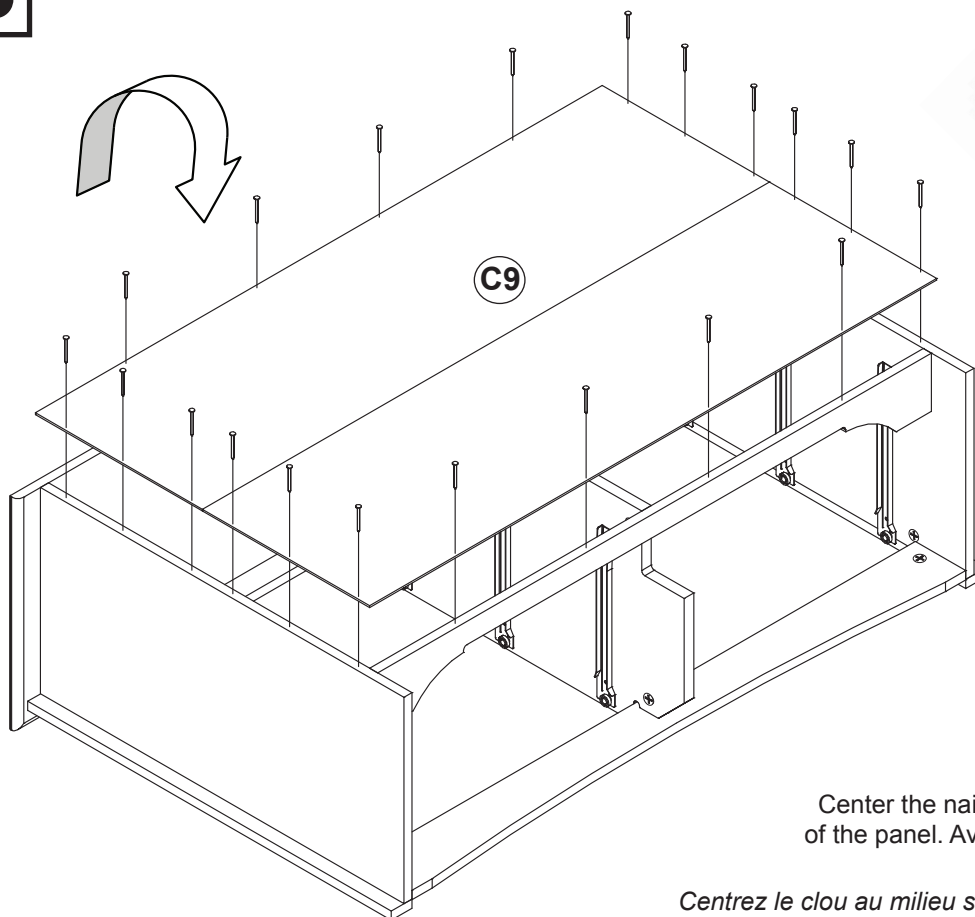

x24

Center the nail in the middle  
of the panel. Avoid the corner  
of the backer  
*Centrez le clou au milieu sur le panneau.  
Évitez le coin du dos.*  
*Centre el clavo en el medio del panel.  
Evite la esquina del respaldo.*

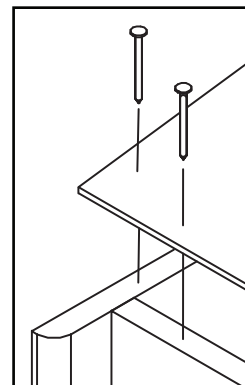

# 14

## Assemble Drawers Montez les tiroir Ensamble los cajones

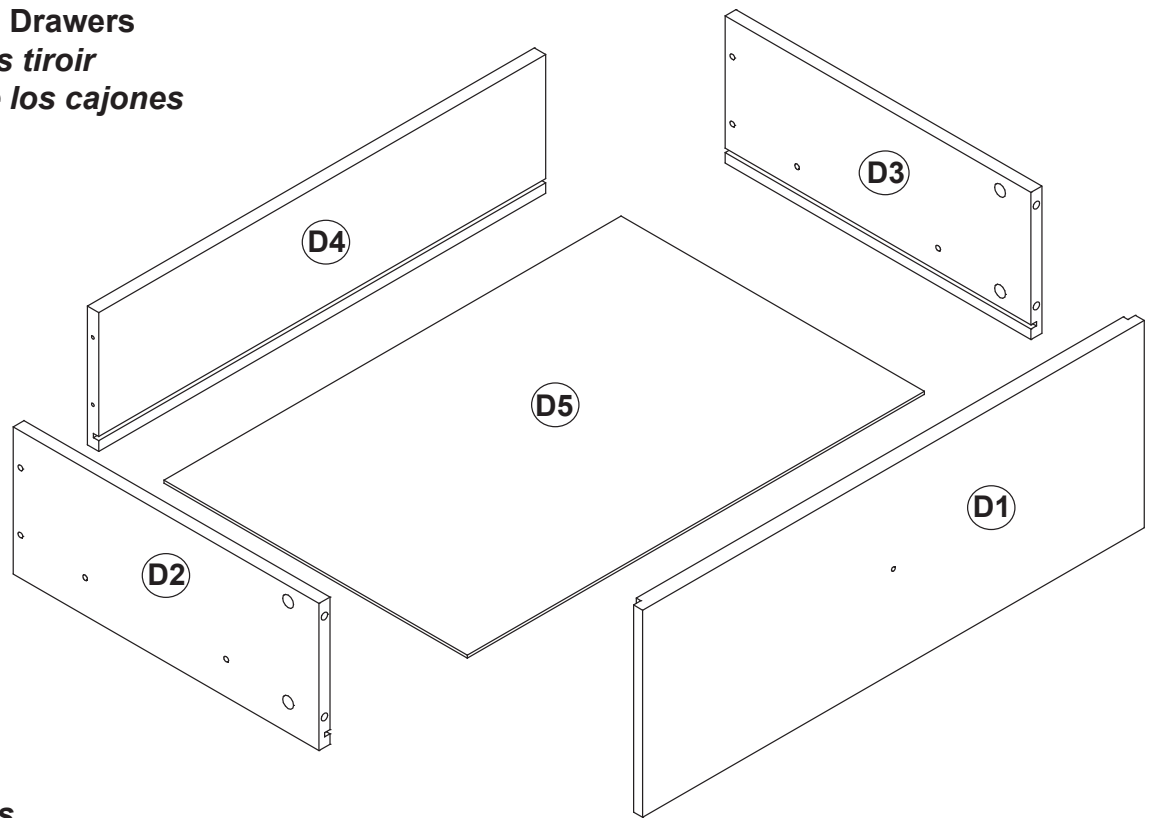

### Drawer Parts Pièces de tiroir Piezas de los cajones

- |  |   |   |   |  |
|--|---|---|---|--|
| <b>D1</b> Drawer Front (6)<br><i>Devant du tiroir</i><br><i>Frente del cajón</i><br>black / noir / negro<br>white / blanc / blanco | <b>D2</b> Left Drawer Side (6)<br><i>Côté gauche du tiroir</i><br><i>Lado del cajón izquierdo</i><br><br><i>Unfinished</i><br><i>non-fini</i><br><i>sin acabado</i> | <b>D3</b> Right Drawer Side (6)<br><i>Côté droit du tiroir</i><br><i>Lado del cajón derecho</i><br><br><i>Unfinished</i><br><i>non-fini</i><br><i>sin acabado</i> | <b>D4</b> Drawer Back (6)<br><i>Arrière du tiroir</i><br><i>Parte posterior del cajón</i><br><br><i>Unfinished</i><br><i>non-fini</i><br><i>sin acabado</i> | <b>D5</b> Drawer Bottom (6)<br><i>Fond du tiroir</i><br><i>Fondo del cajón</i><br><br><i>Unfinished</i><br><i>non-fini</i><br><i>sin acabado</i> |
|--|---|---|---|--|

**a**

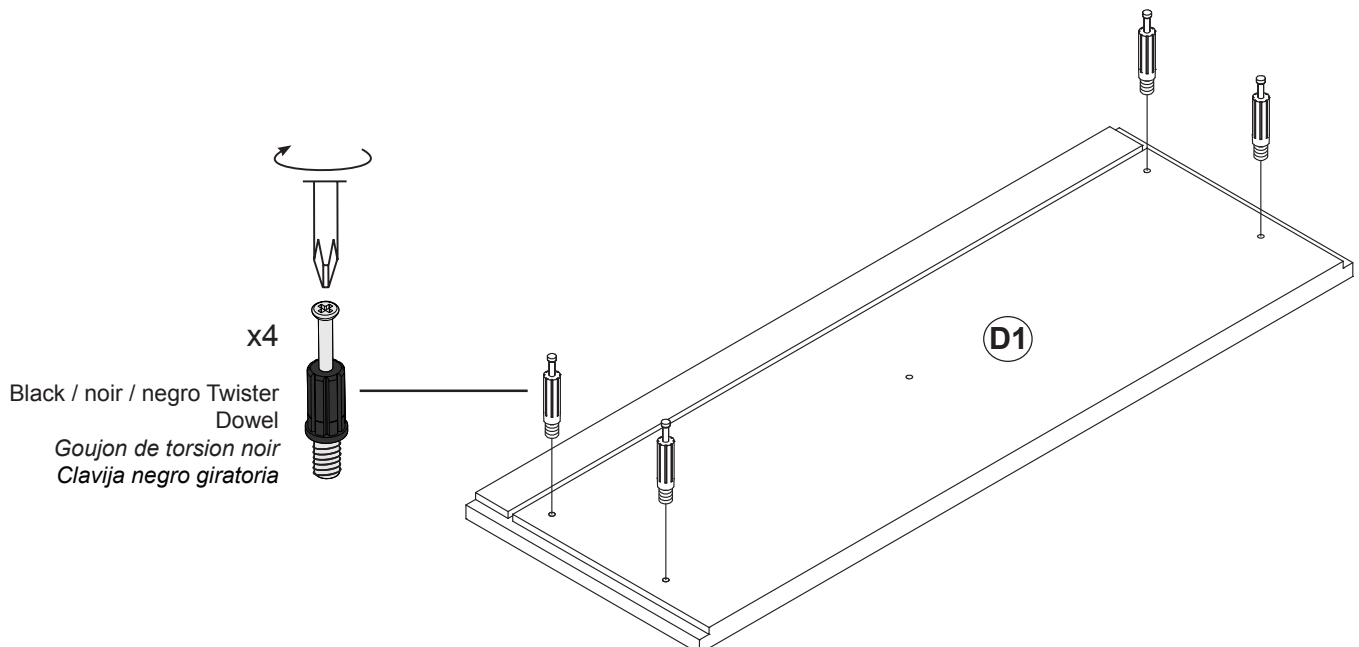

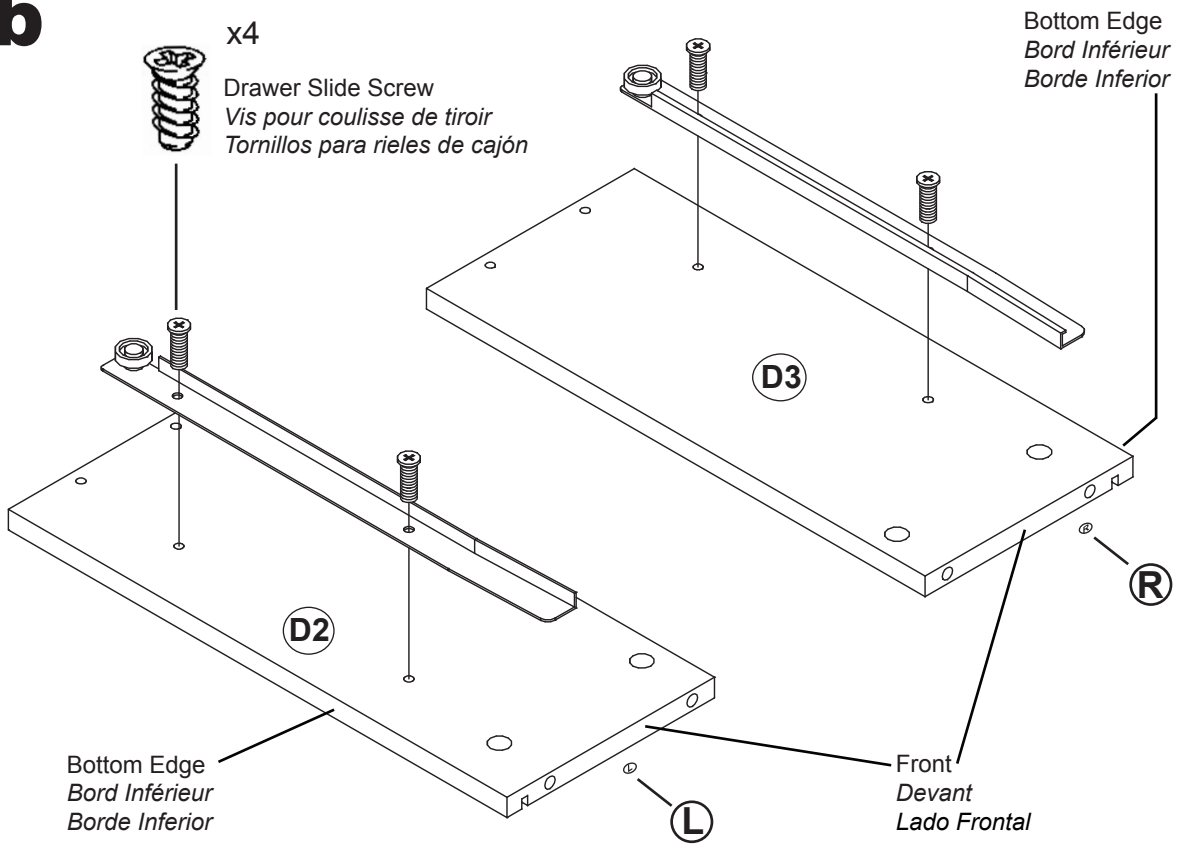
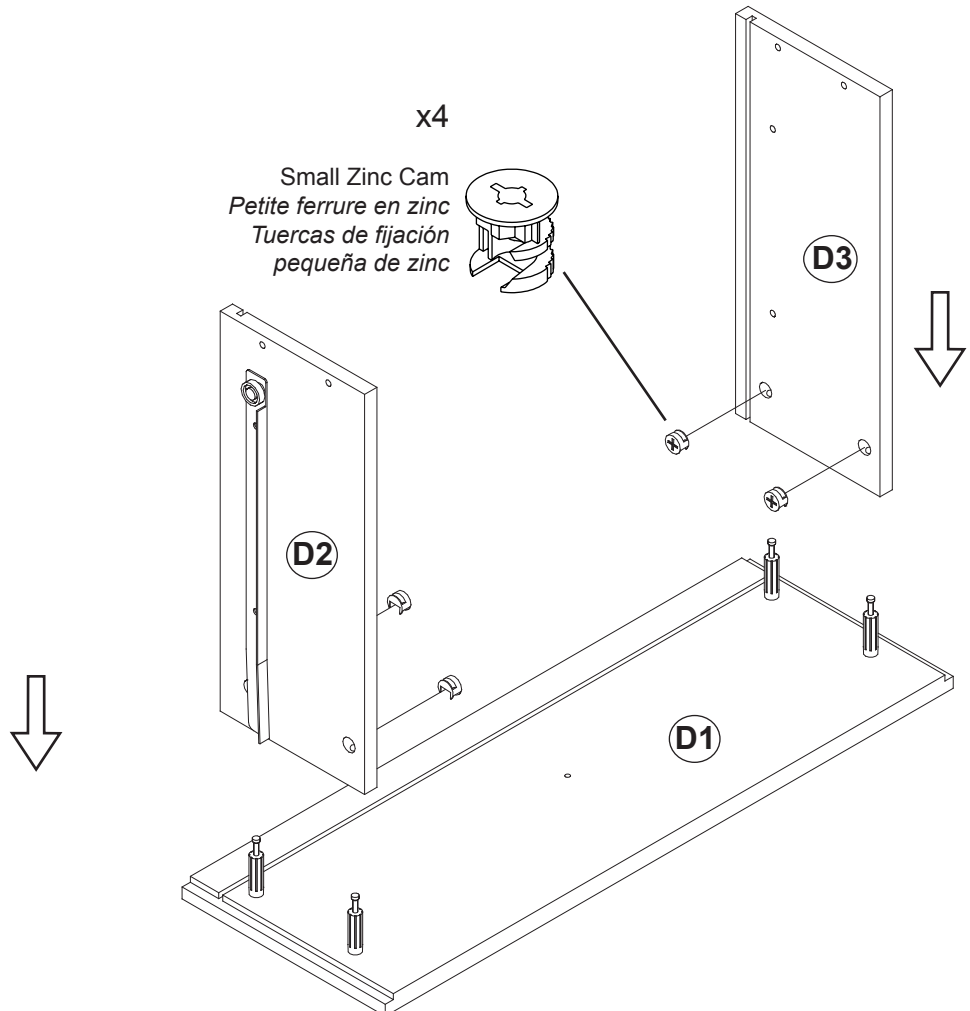
**b****c**

**d**

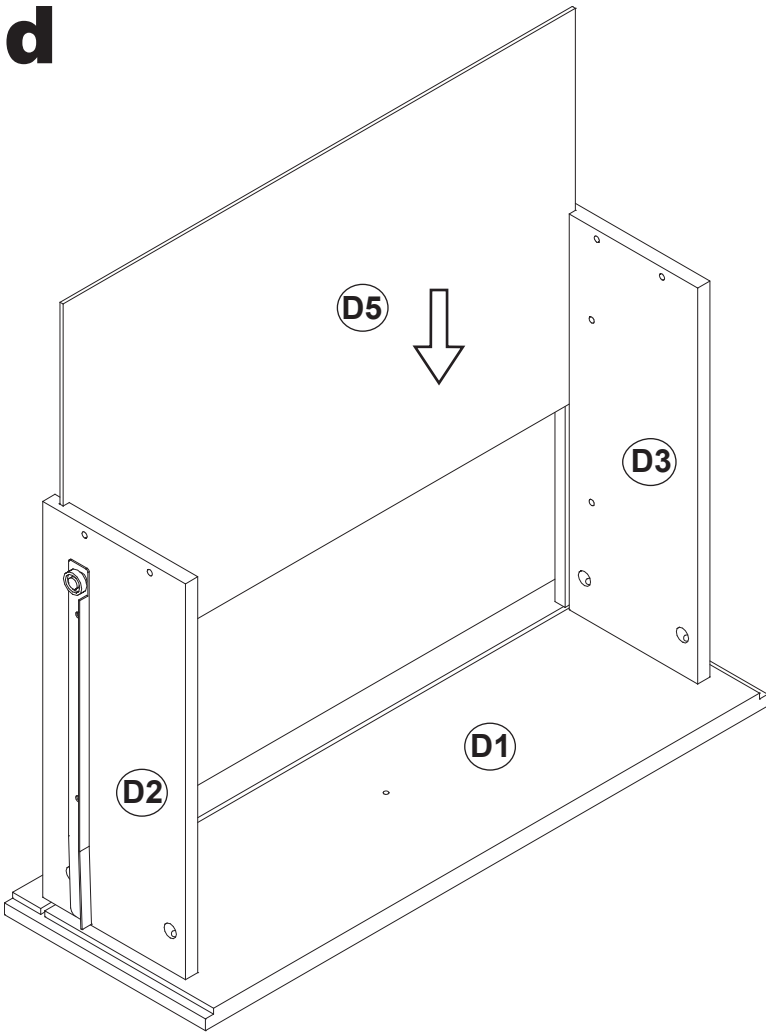

**e**

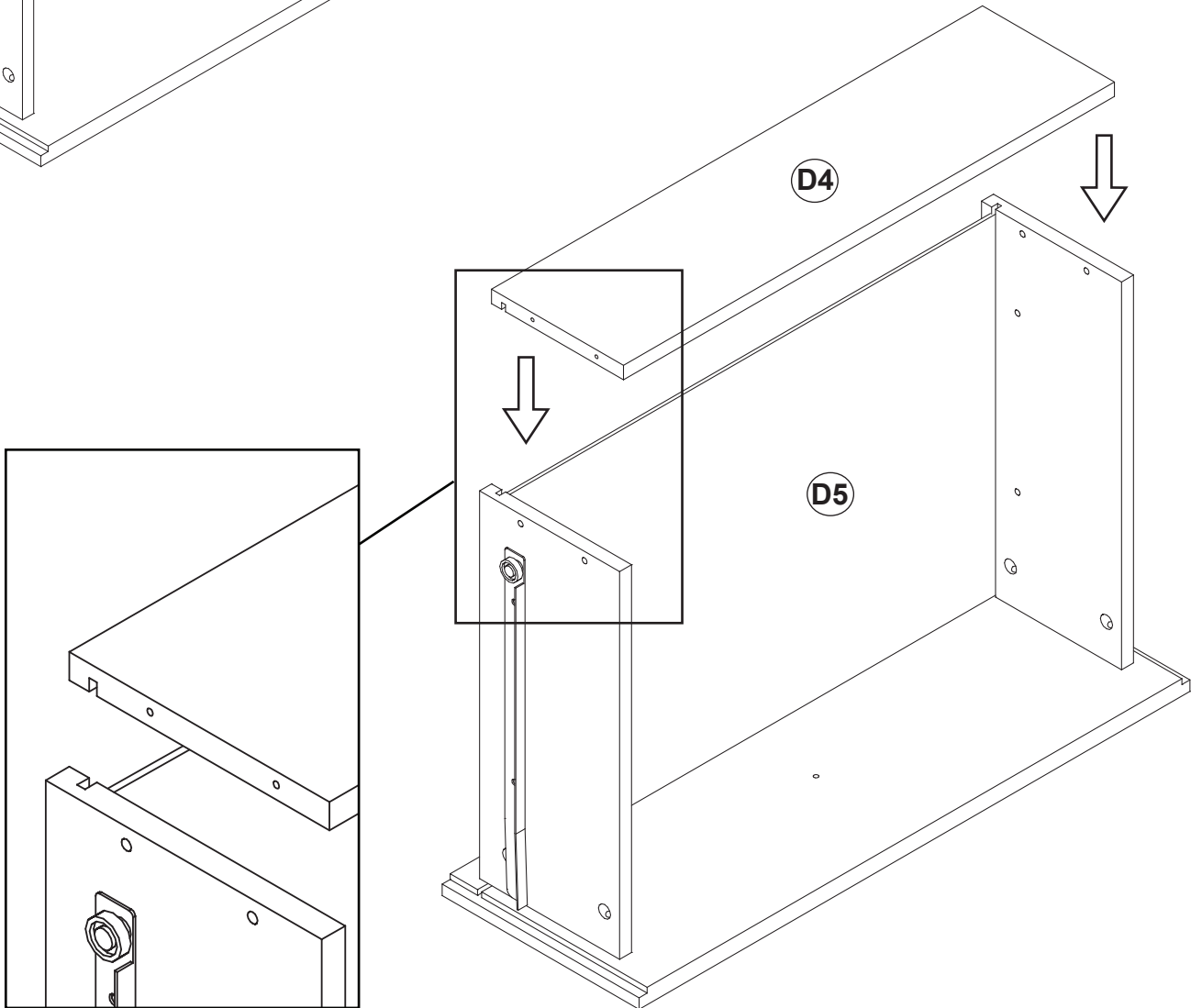

**f**

x4

#8 - 1½" Screws  
 Vis no.8 - 1½ po.  
 Tornillo de 1½"

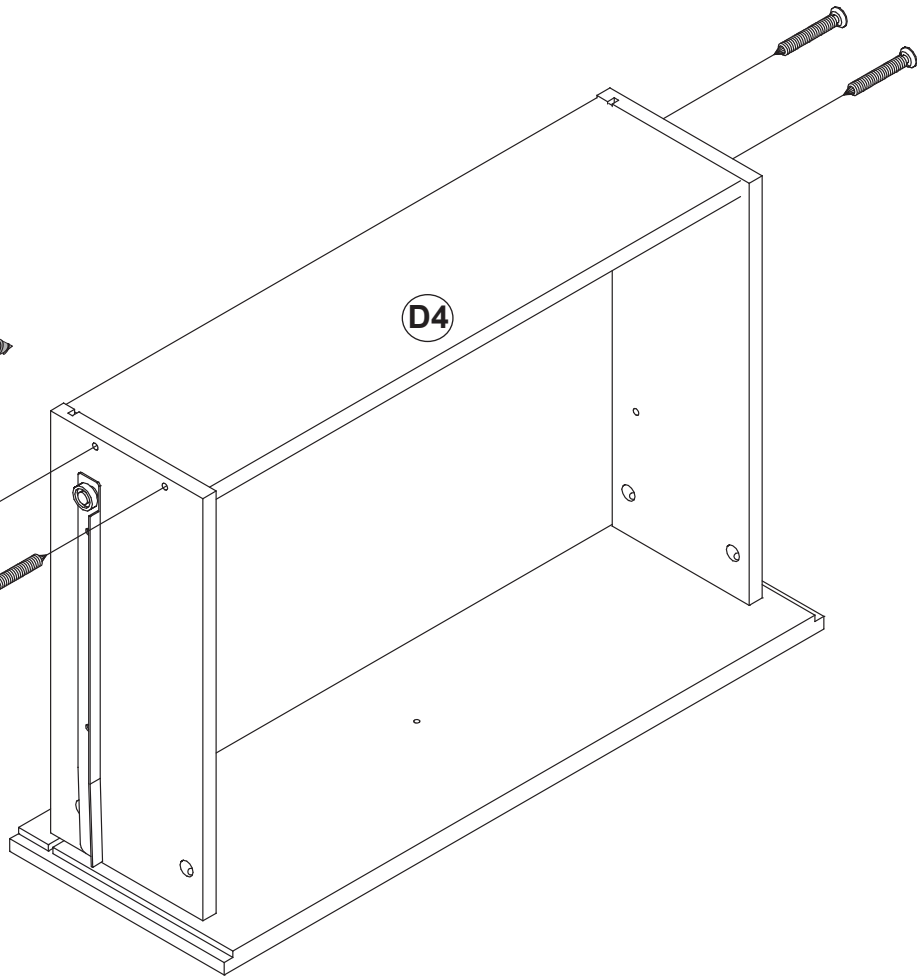
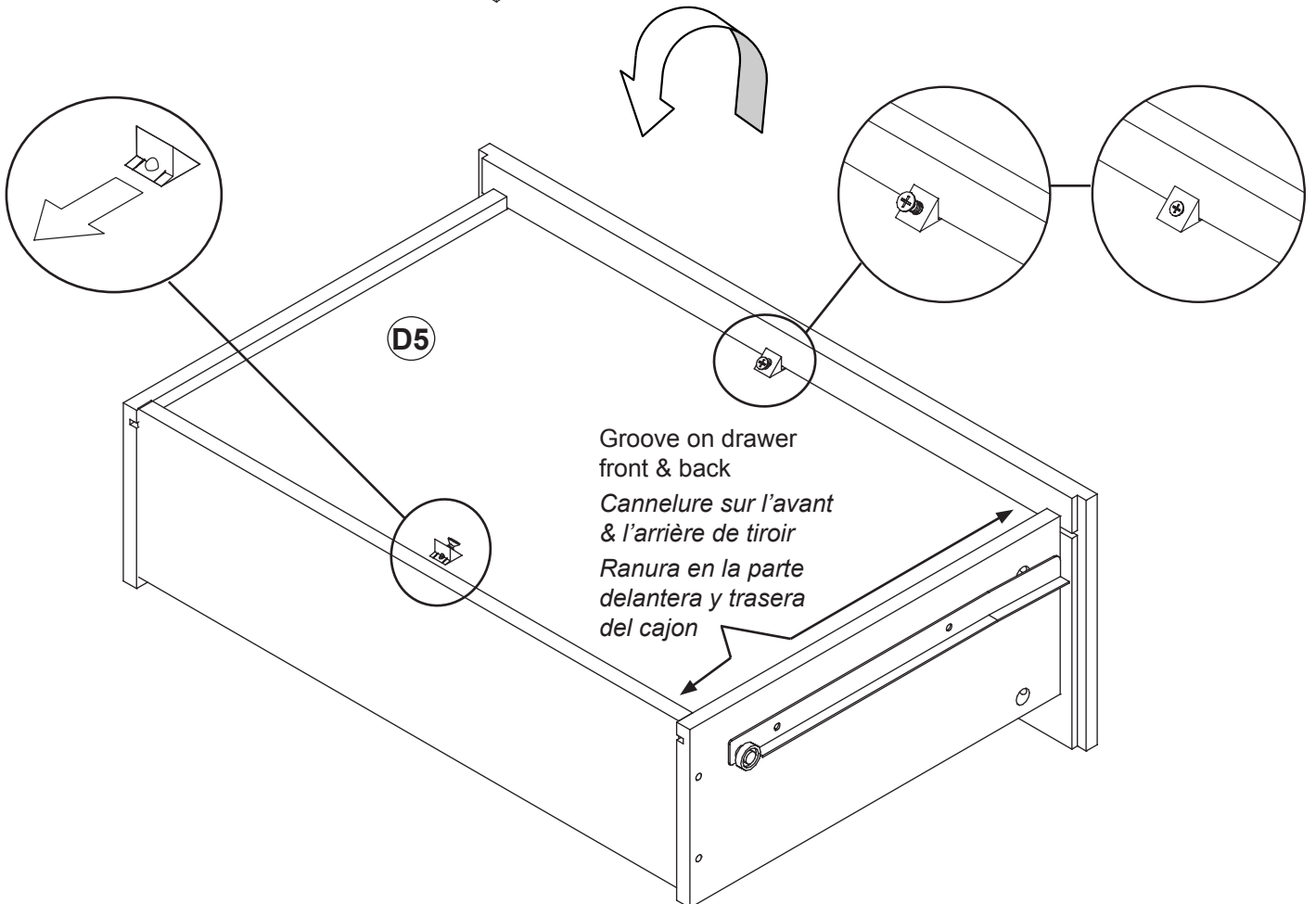
**g**

**h**

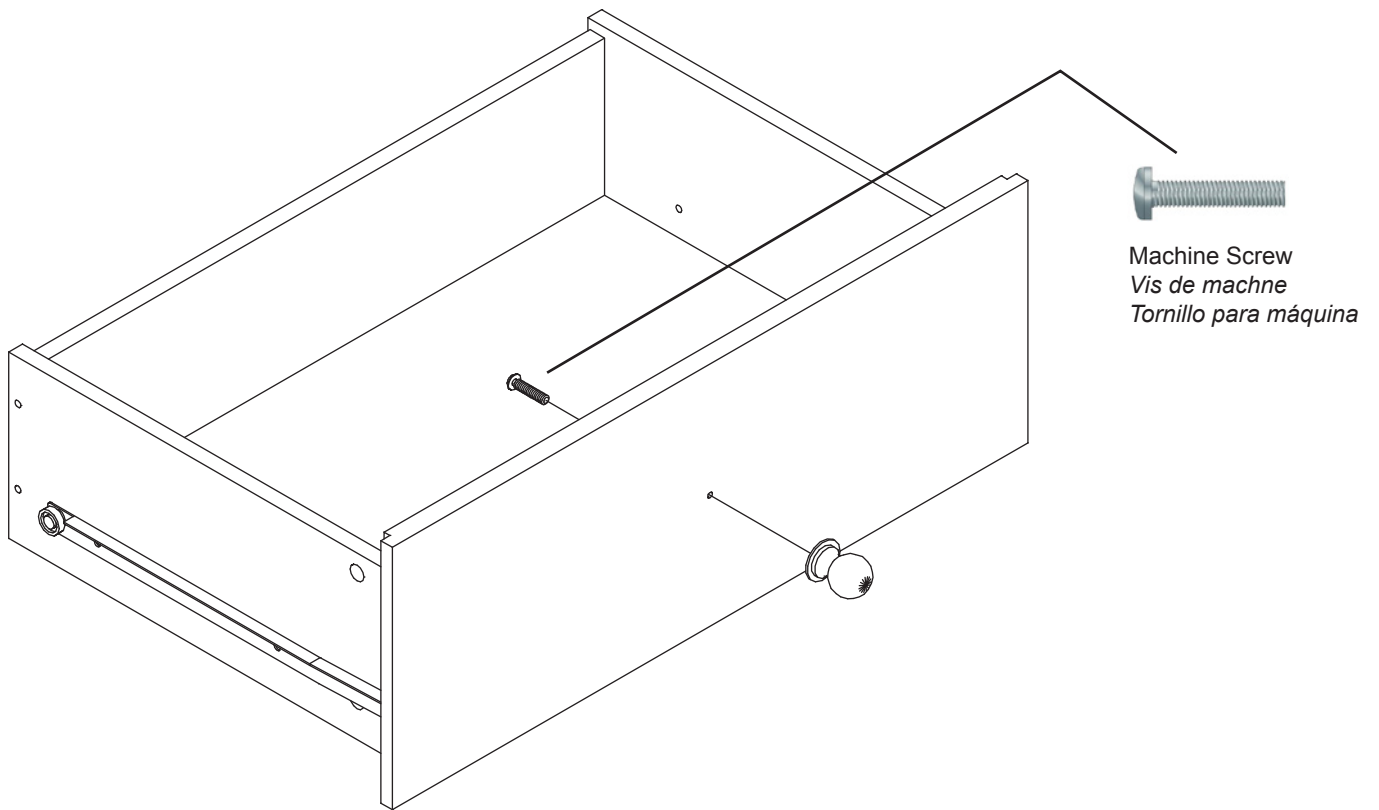

**i** Insert drawers  
*Insérez les tiroirs*  
*Inserte los cajones*

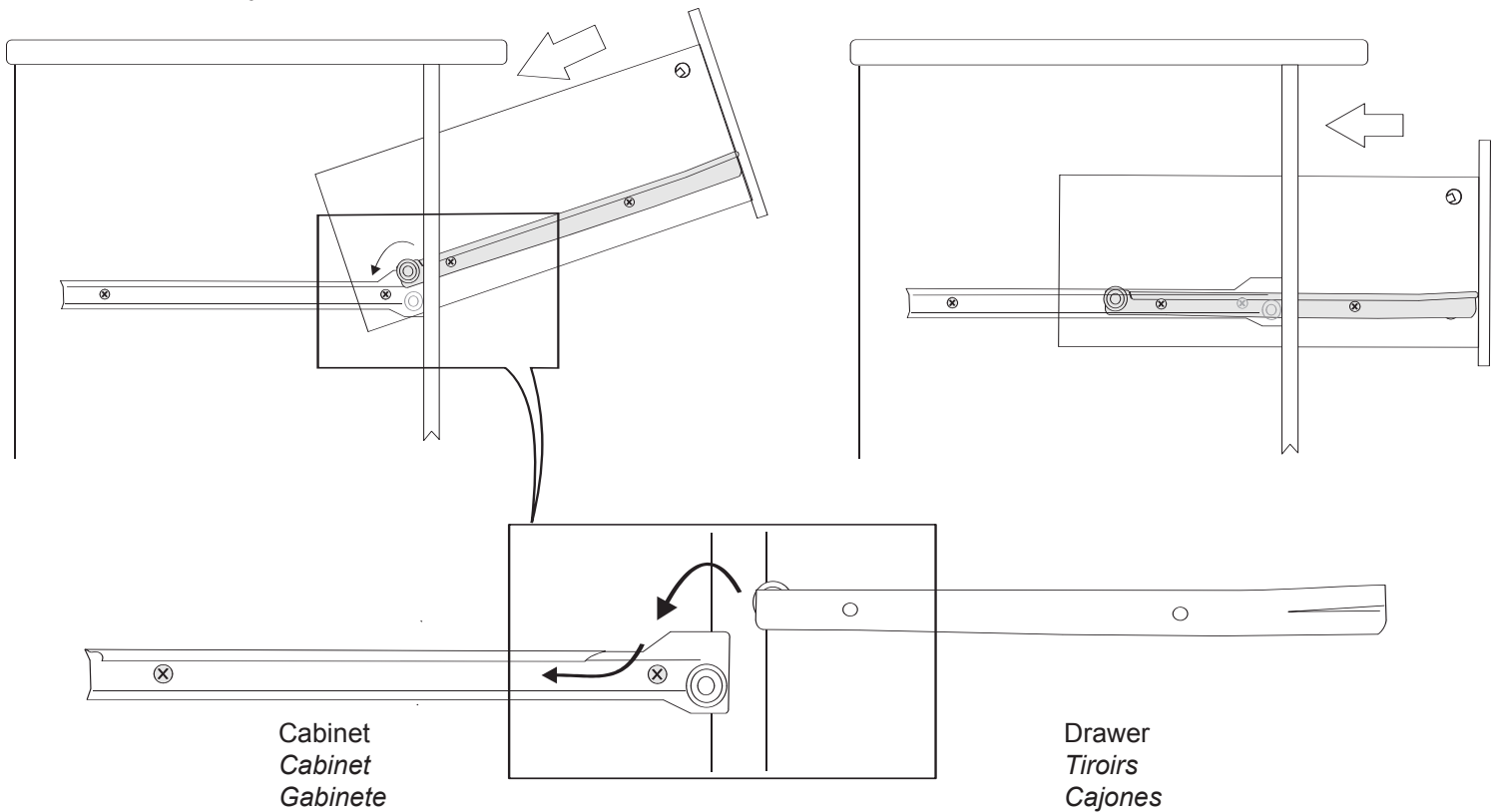

**Note:** When drawers are installed correctly, you will not be able to remove them without first lifting up the drawer front.

**Note:** Quand des tiroirs sont installés correctement, vous ne pourrez pas les enlever sans se soulever d'abord vers le haut de l'avant de tiroir.

**Aviso:** una vez que los cajones se hayan instalado correctamente, no podrá sacarlos sin antes levantar la parte frontal del cajón.

# Attaching & Using the Cable Tie

## Attacher et Utilisation de l'Attache de Câble

### Instalando y utilizando el cable sujetador

<p><b>Safety Notice</b></p> <p>The Consumer Product Safety Commission recommends anchoring furniture in homes where children live or visit. In order to protect you and your family the manufacturer of this product has included an easy to install safety device. Please make sure that it is installed according to the following instructions.</p>	<p><b>Avis de Sécurité</b></p> <p>La Commission de Sécurité de Produit de consommation recommande de mettre à l'ancre des meubles dans des maisons où les enfants vivent ou la visite. Pour vous protéger et votre famille le fabricant de ce produit a inclus un facile d'installer le dispositif de sécurité. Assurez-vous S'il vous plaît qu'il est installé selon les instructions suivantes.</p>	<p><b>Noticia de seguridad</b></p> <p>La comisión de seguridad de productos de consumo recomienda anclar muebles en hogares donde viven niños o ellos visitan. Con el fin de proteger a su familia y a usted el fabricante de este producto ha incluido un dispositivo de seguridad de facil instalacion. Por favor seguresse de que esta instalado de acuerdo a las siguientes instrucciones</p>
--	---	---

**a** With the #6-3/4" screw, attach one of the mounting bases to one of the sides 1 inch from the top.

*Avec le #6 - 3/4 po. vis attacher une des bases montant à un des côtés 1 pouce du sommet.*

*Con el torillo núm. 6 de ¾ de pulg., fije una de las bases de montaje en el borde posterior de uno de los lados de a 1 pulg. (2.5 cm) de la parte superior.*

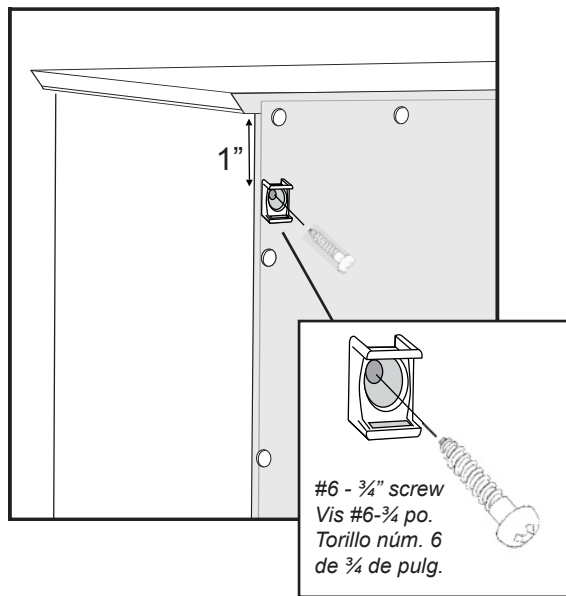

**b** Attach the 2nd mounting base to the wall 2" lower than the one on the cabinet

**Important:** Find a wall stud and attach the mounting base with a 3½" screw. If you cannot locate a stud, use an approved wall mounting system

*Attachez la deuxième base de support au mur 2" plus bas que l'un sur le cabinet.*

**Important:** Trouvez un clou de mur et attachez la base montant avec un 3½ po. vis. Si vous ne pouvez pas localiser un clou, utilisez un système fixé au mur approuvé.

*Fije la segunda base de montaje segunda en la pared 2 pulg. (5.1 cm) más abajo que el que está en el gabinete*

**Importante:** Busque una viga montante de la pared y fije la base de montaje con un tornillo de 3½ pulg. (3.8 cm). Si no puede localizar una viga montante, utilice un sistema de montaje en pared aprobado

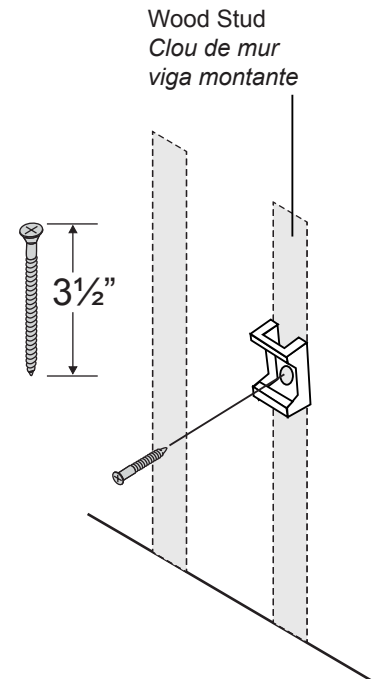

**c** Feed the cable tie through each mounting base and then through the locking mechanism to tighten.

*Insérez l'attache de câble par chacun montant la base et alors par le mécanisme de verrouillage pour resserrer*

*Pase el sujetador de cable a través de cada base de montaje y luego a través del mecanismo de cierre para sujetar bien.*

