

Montageanweisung / Installation instructions / Instruction de montage / Istruzioni di montaggio  
 Montagehandling / Instrukcja montażu / Montaj talimatlar / Osszeszerelési útmutató / Nàvod k montáži /  
 Nàvod na montáž / Instrucțiune de montaj / Инструкция по монтажу / Montaj talimatina

# BOOST

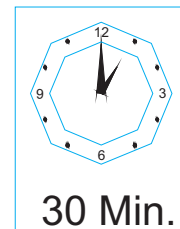
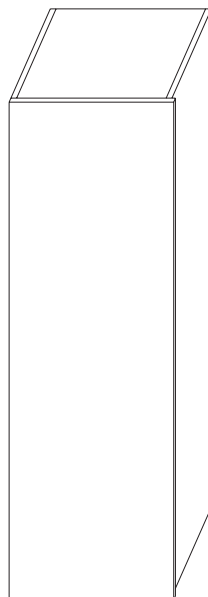
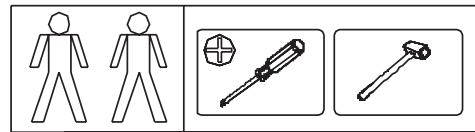

**D** Bitte lesen Sie diese Montageanleitung gut durch, da wir für Fehler, die durch falsche Montage entstehen, keine Haftung übernehmen!

**GB** Please read these installation instructions through carefully as we cannot accept any liability for faults occurring as a result of incorrect installation!

**CZ** Přečtěte si prosím pozorně tento návod k montáži, aby jste předešli chybám vzniklých špatnou montáží, za které neručíme!

**F** Veuillez lire attentivement cette notice de montage, car nous déclinons toute responsabilité en cas d'erreurs découlant d'un montage erroné !

**I** Prego leggere attentamente le istruzioni per il montaggio, poiché decliniamo qualsiasi responsabilità per difetti derivanti da un montaggio errato

**NL** Leest u alstublieft deze montagehandleiding goed door, voor fouten door verkeerde montage zijn wij niet verantwoordelijk.

**PL** Proszę uważnie zapoznać się z instrukcją montażu, ponieważ nie ponosimy odpowiedzialności za niewłaściwy montaż.

**HU** Kérjük, olvassa el figyelmesen ezt az összeszerelési útmutatót, mert a helytelen összeszerelésből a dődő hibáért nem vállalunk felelősséget!

**SK** Prosíme, dobre prečítajte si tento návod na montáž, pretože nepreberáme žiadne ručenie za chyby, ktoré vzniknú na základe chybnej montáže!

**RO** Vă rugăm să citiți cu atenție aceste instrucțiuni de montaj deoarece nu preluăm garanția pentru defecte ce apar datorită unui montaj incorrect!

**RUS** Пожалуйста, внимательно ознакомьтесь с данной инструкцией по монтажу, поскольку мы не несем ответственности за ошибки, причиной которых является неправильный монтаж.

**TU** İlk önce kullanma klavuzunu iyi okuyun, yalnızca montaj yapmanızın sorumluluğu bizde değildir.

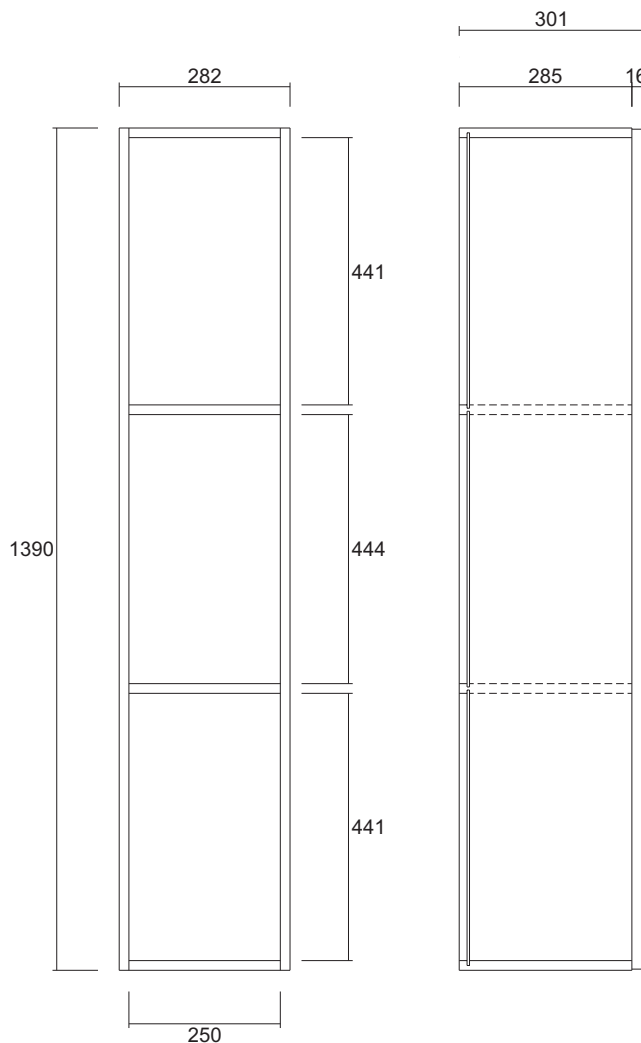



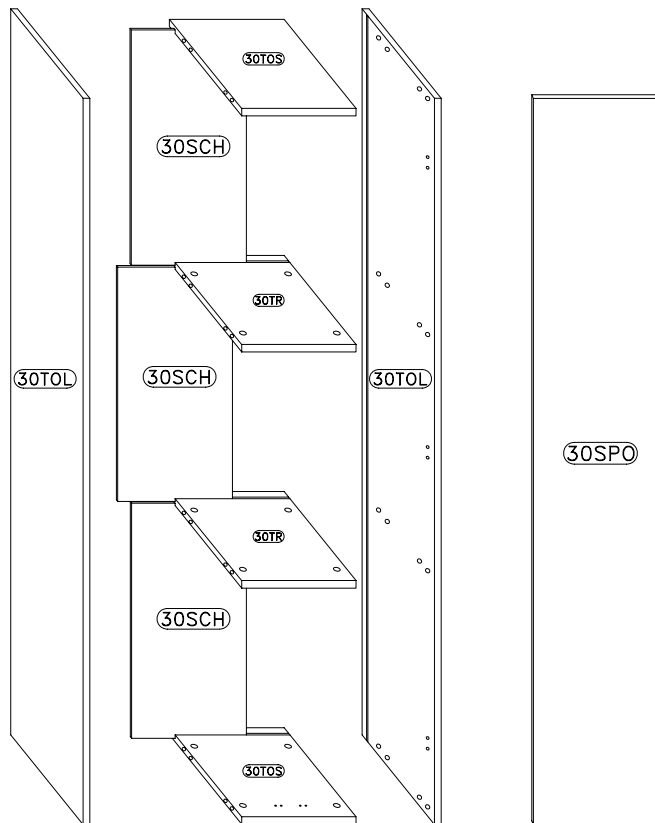
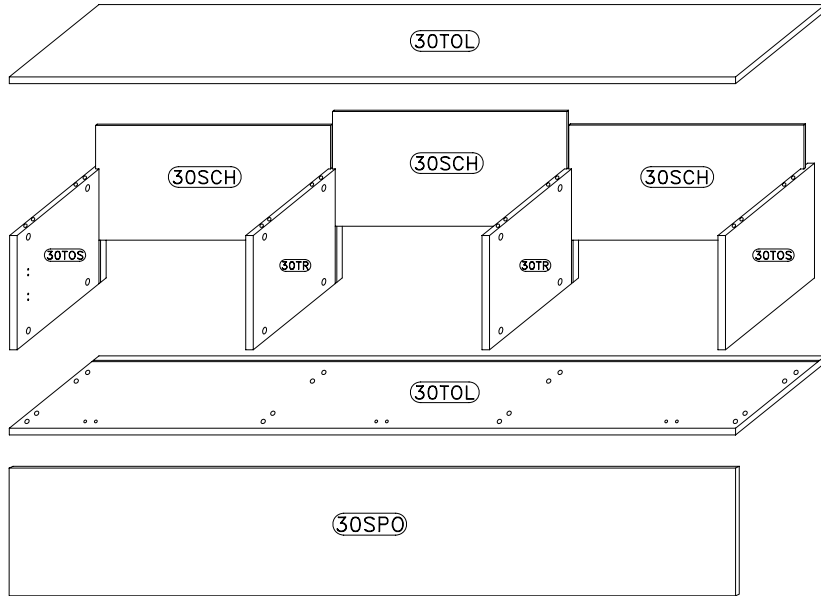
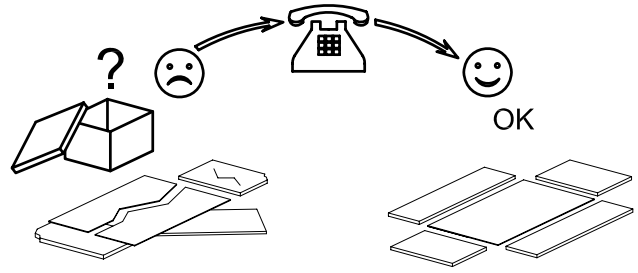
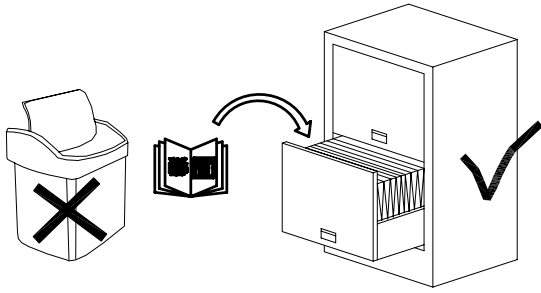



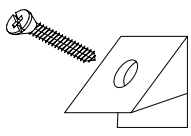

# S E R V I C E K A R T E

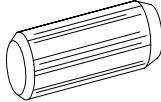
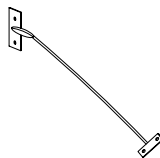
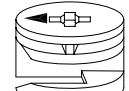
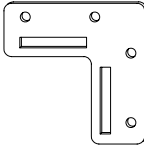
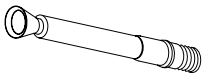

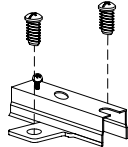
# ONDERDELEN LYST-SERVICEKARTE-FORMULAIRE DEMANDES SAV-SPAREPARTS LIST-SCHEDA DI SERVIZIO

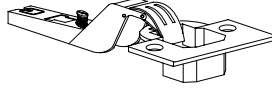

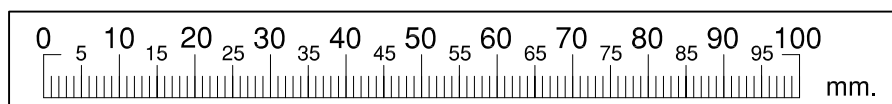

BESLAG-BESCHLAEGE - QUINCALLERIE - HARDWARE - FERRAMENTA

A  x14	P  x2
B  8x30 mm. x16	P2  x2
C  Ø16 mm. x16	P52  x4
D  x16	M2  3.5x16 mm. x8
L2  4x16 mm. x6	N1  x3
L18  3,5x20 mm. x16	O2  x3
P12  Ø20 mm. x16	

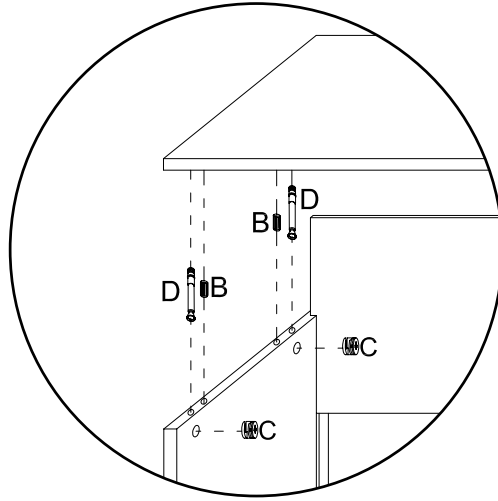
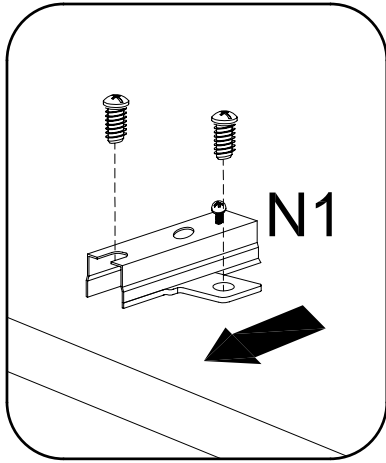

1

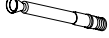

- B**  8x30 mm. **x16**
- C**   $\varnothing 16$  mm. **x16**
- D**  **x16**
- N1**  **x3**

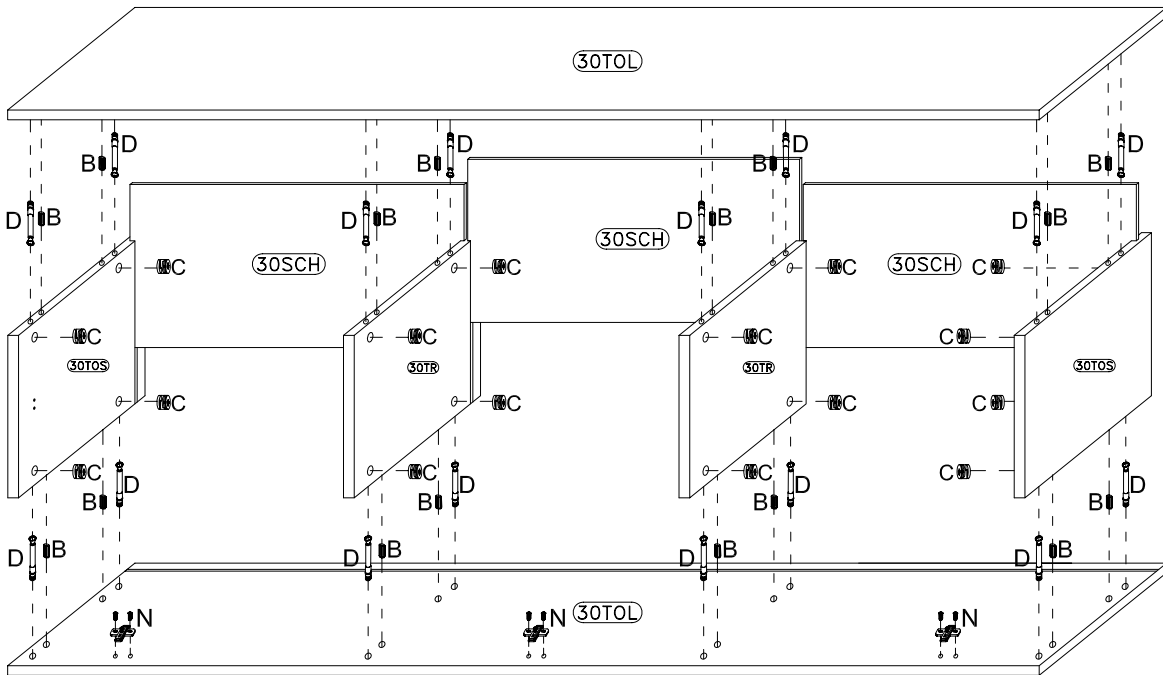

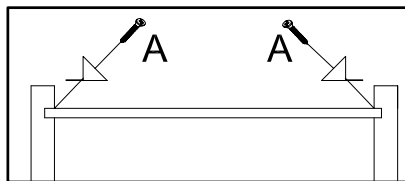

2

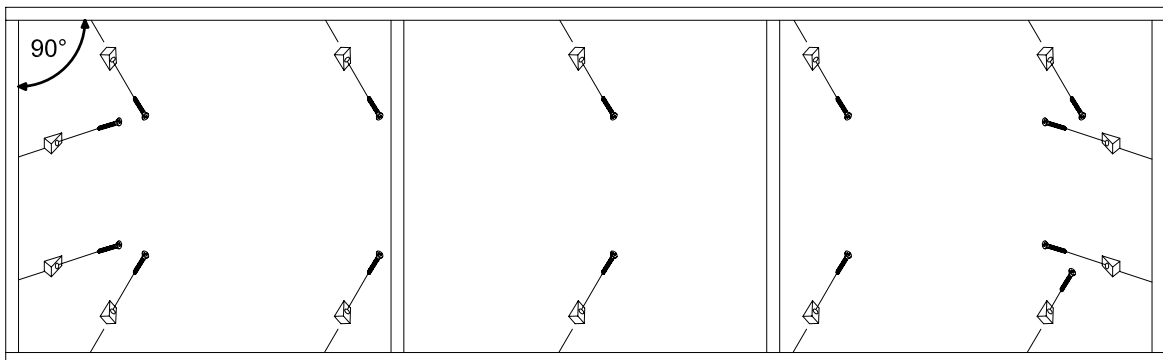

- A**  **x14**



# 3

- O2  x3
- L2  4x16 mm. x6
- P  x2

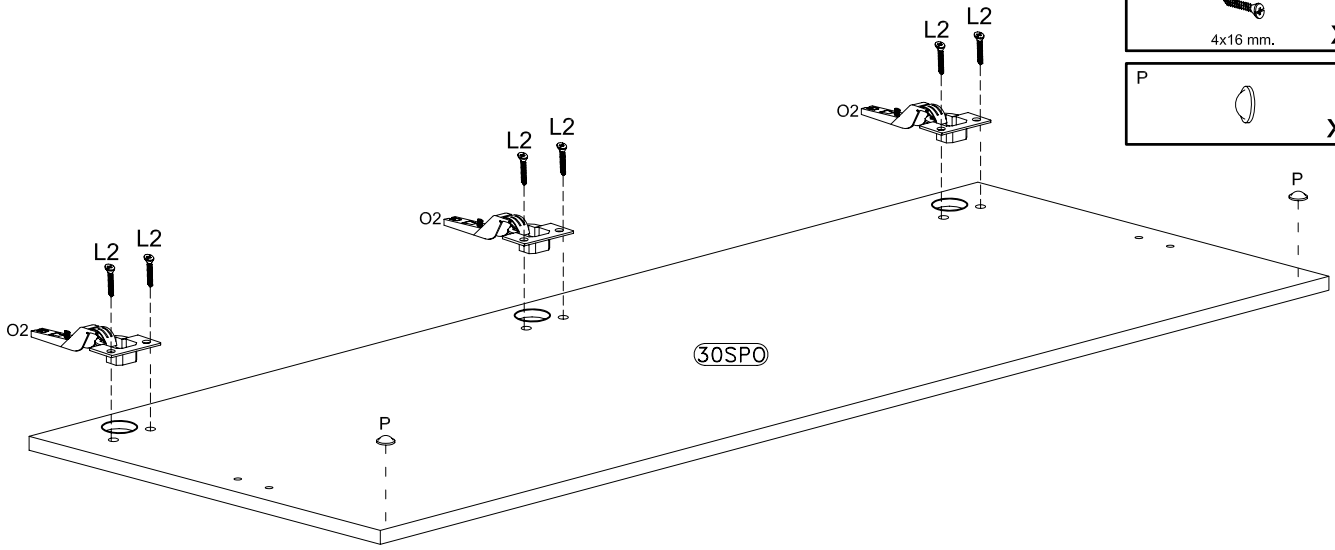

# 4

- P12  Ø20 mm. x16

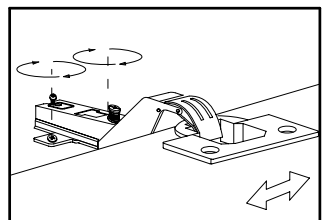
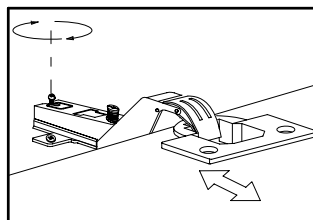
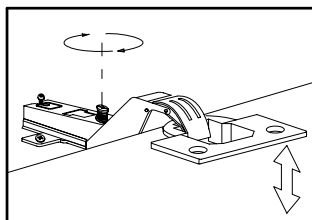
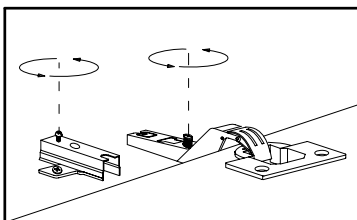
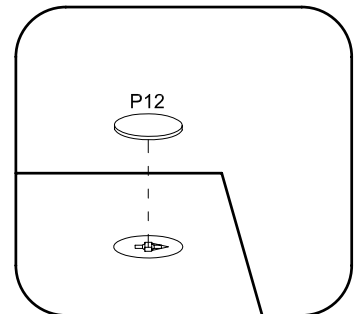
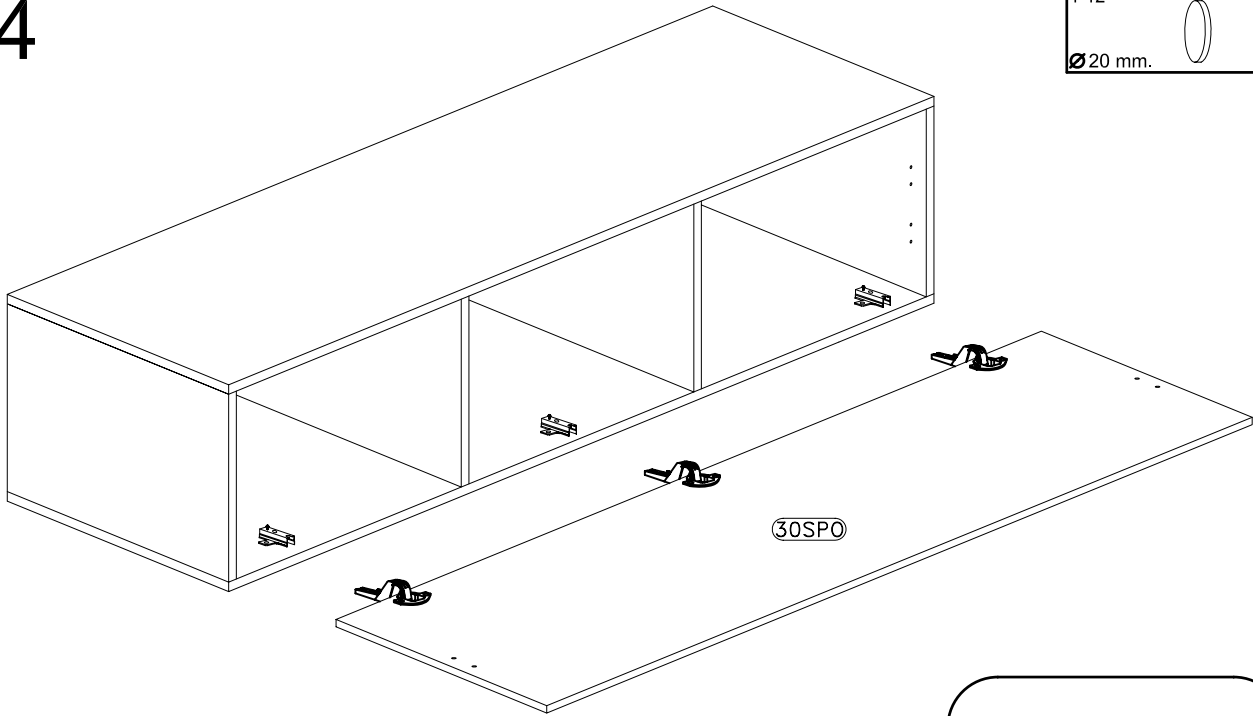

5

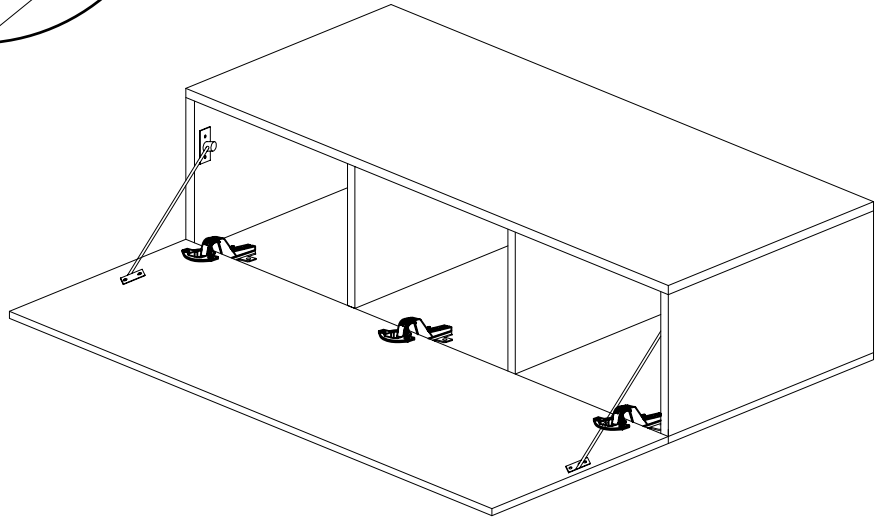
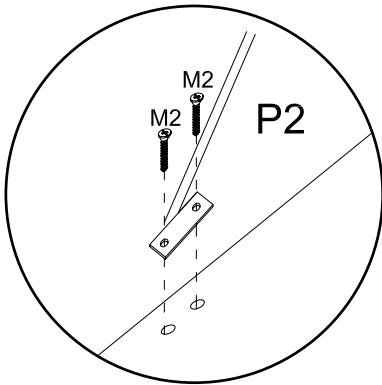
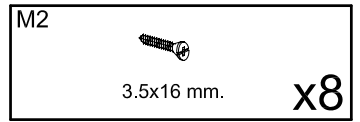
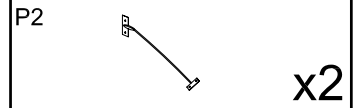
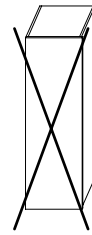
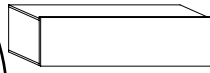
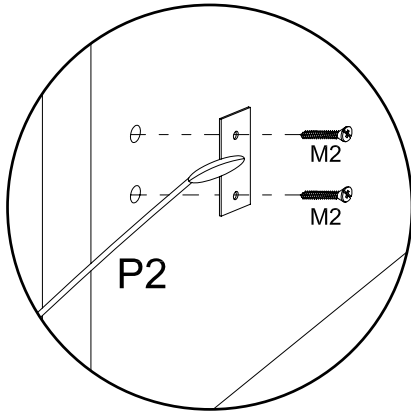

6

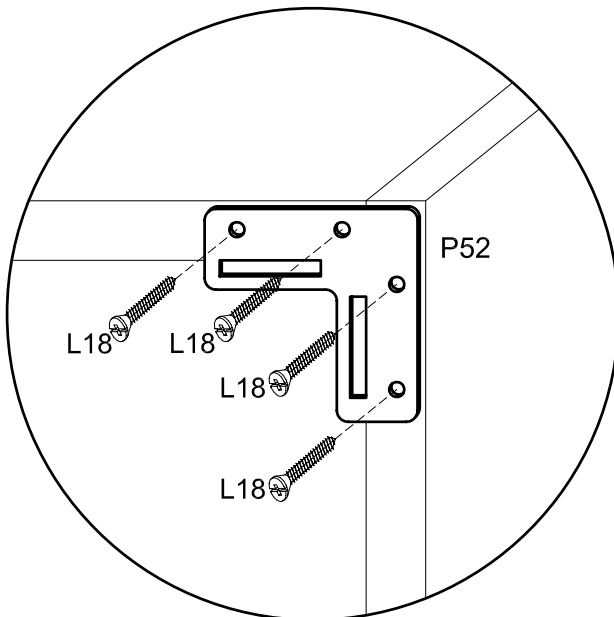
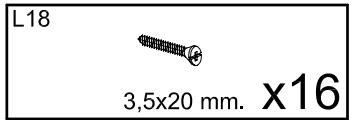
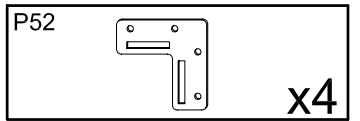
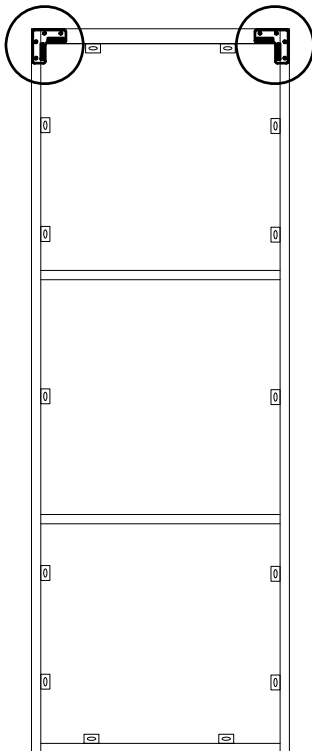
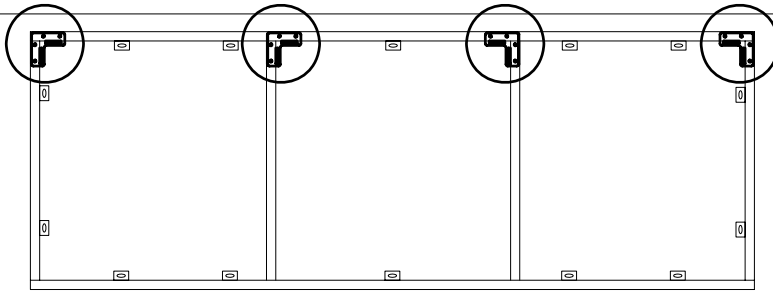

7

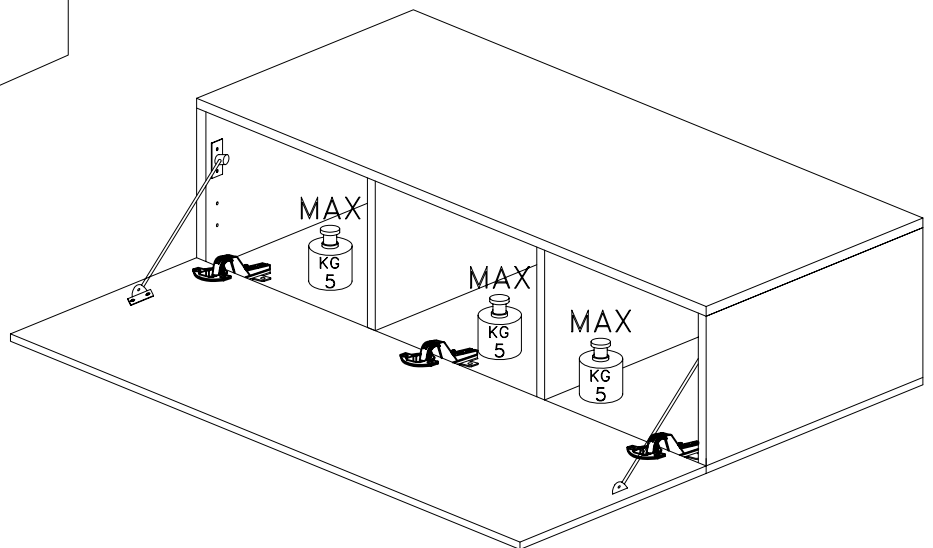
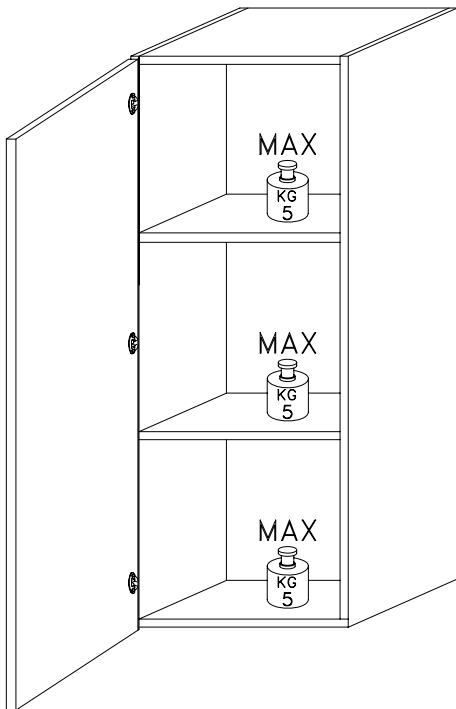
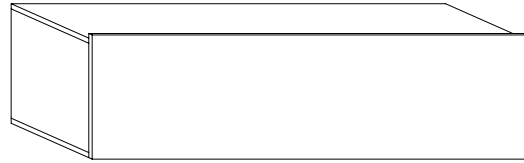
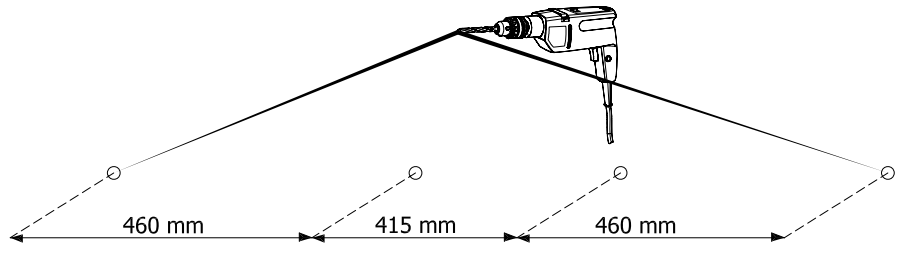
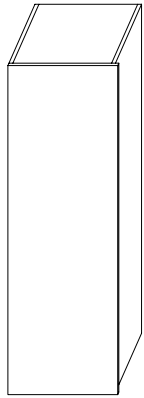
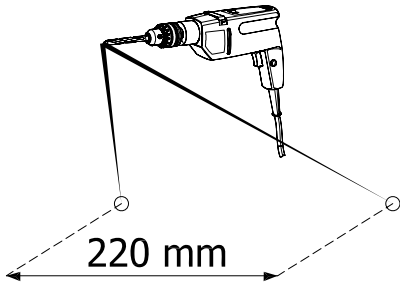

Montageanweisung / Installation instructions / Instruction de montage / Istruzioni di montaggio  
 Montagehandling / Instrukcja montażu / Montaj talimatlar / Osszeszerelési útmutató / Nàvod k montáži /  
 Nàvod na montáž / Instrucțiune de montaj / Инструкция по монтажу / Montaj talimatina

# BOOST

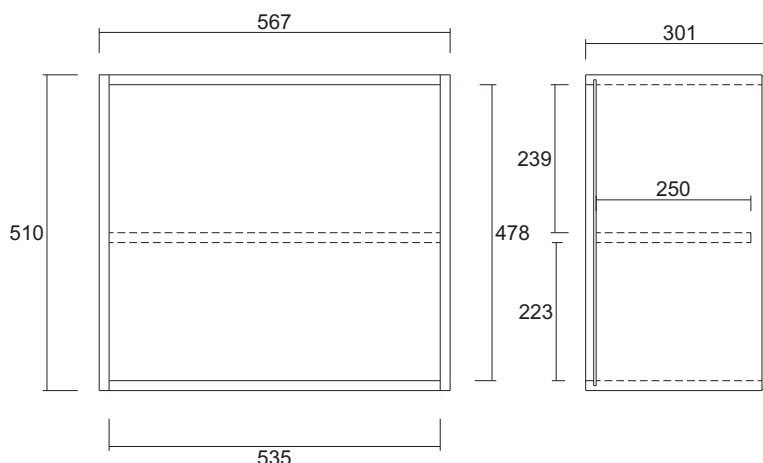
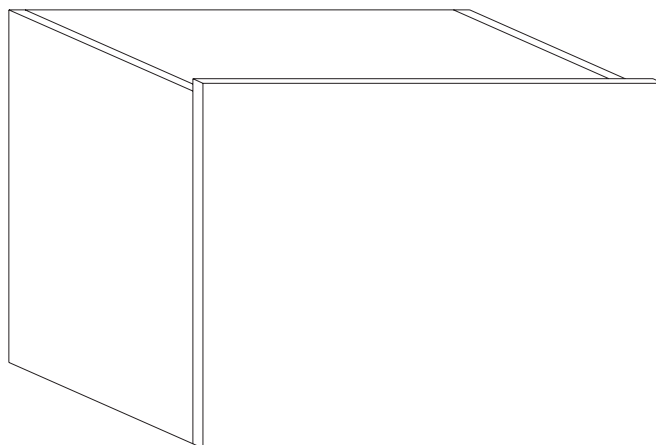
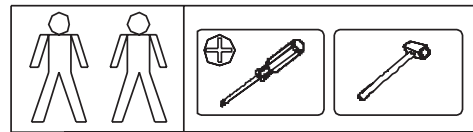

**NL** Leest u alstublieft deze montagehandleiding goed door, voor fouten door verkeerde montage zijn wij niet verantwoordelijk.

**PL** Proszę uważnie zapoznać się z instrukcją montażu, ponieważ nie ponosimy odpowiedzialności za niewłaściwy montaż.

**HU** Kérjük, olvassa el figyelmesen ezt az összeszerelési útmutatót, mert a helytelen összeszerelésből a dődő hibáért nem vállalunk felelősséget!

**SK** Prosíme, dobre prečítajte si tento návod na montáž, pretože nepreberáme žiadne ručenie za chyby, ktoré vzniknú na základe chybnej montáže!

**RO** Vă rugăm să citiți cu atenție aceste instrucțiuni de montaj deoarece nu preluăm garanția pentru defecte ce apar datorită unui montaj incorrect!

**RUS** Пожалуйста, внимательно ознакомьтесь с данной инструкцией по монтажу, поскольку мы не несем ответственности за ошибки, причиной которых является неправильный монтаж.

**TU** İlk önce kullanma klavuzunu iyi okuyun, yalnızca montaj yapmanızın sorumluluğu bizde değildir.

**D** Bitte lesen Sie diese Montageanleitung gut durch, da wir für Fehler, die durch falsche Montage entstehen, keine Haftung übernehmen!

**GB** Please read these installation instructions through carefully as we cannot accept any liability for faults occurring as a result of incorrect installation!

**CZ** Přečtěte si prosím pozorně tento návod k montáži, aby jste předešli chybám vzniklých špatnou montáží, za které neručíme!

**F** Veuillez lire attentivement cette notice de montage, car nous déclinons toute responsabilité en cas d'erreurs découlant d'un montage erroné !

**I** Prego leggere attentamente le istruzioni per il montaggio, poiché decliniamo qualsiasi responsabilità per difetti derivanti da un montaggio errato

Total Kollis 1 Stuecke  
 Total colli 1 pieces  
 Numero total des colis: 1  
 Colli totali 1  
 Totaal 1 colli's  
 Razem sztuk 1  
 Toplam parçalar 1  
 количество Всего 1

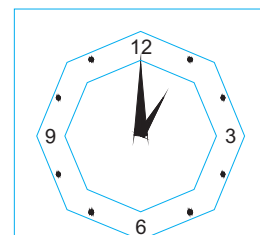







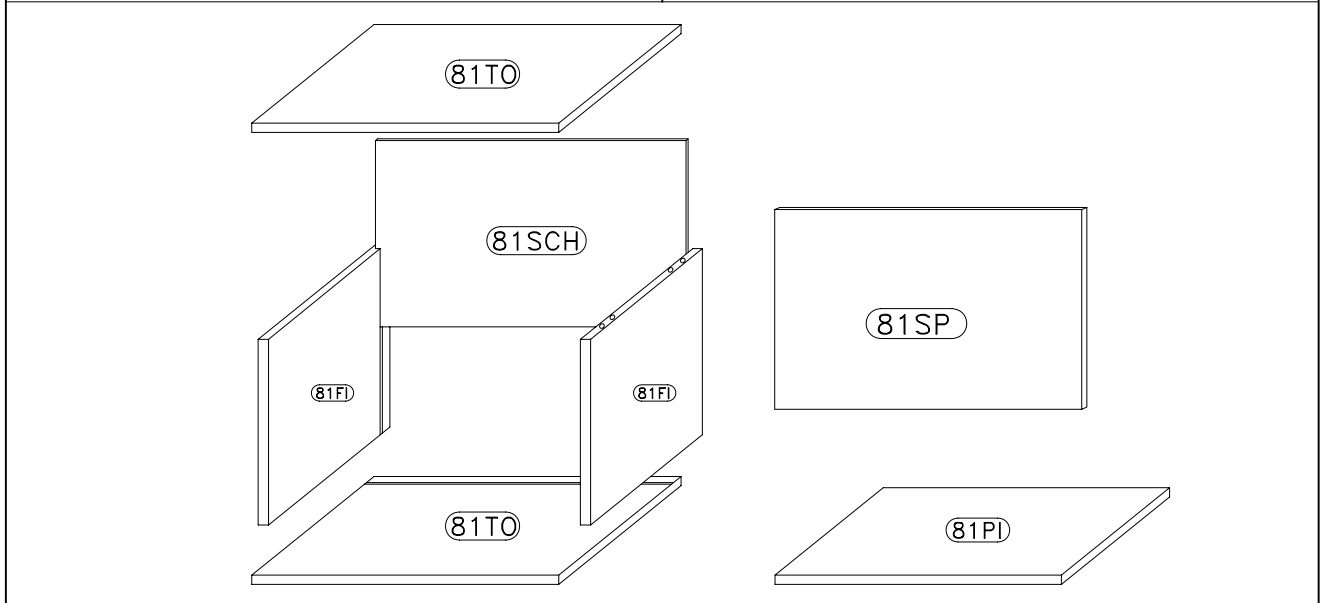
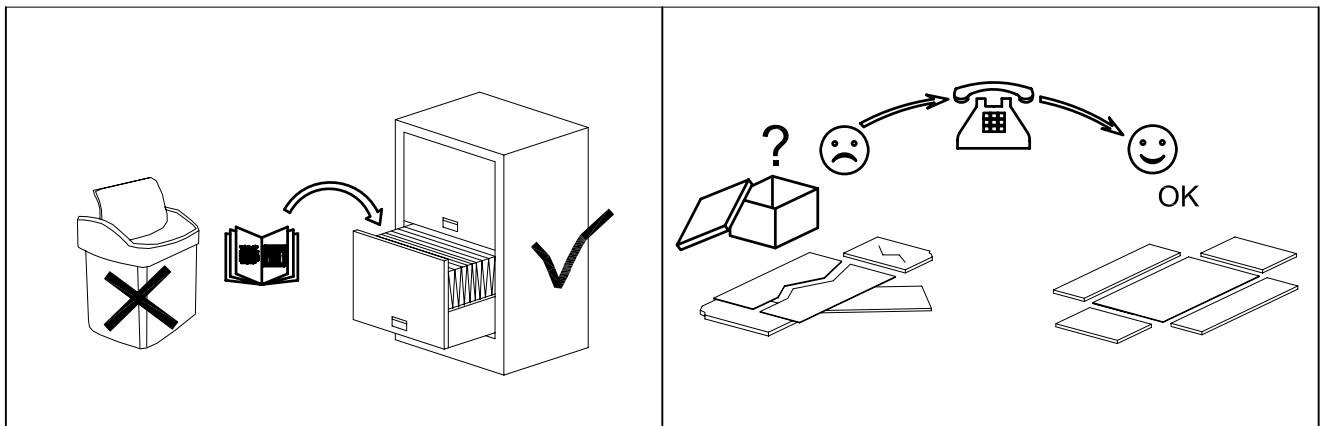

30 Min.

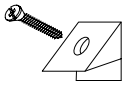

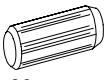
# ONDERDELEN LYST-SERVICEKARTE-FORMULAIRE DEMANDES SAV-SPAREPARTS LIST-SCHEDA DI SERVIZIO

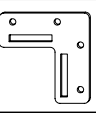
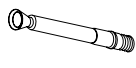
BESLAG-BESCHLAEGE - QUINCALLERIE - HARDWARE - FERRAMENTA

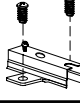

<p>A</p>  <p>x8</p>	<p>P</p>  <p>x2</p>
<p>B</p>  <p>8x30 mm.</p> <p>x8</p>	<p>P12</p>  <p>ø20 mm.</p> <p>x8</p>
<p>C</p>  <p>ø16 mm.</p> <p>x8</p>	<p>P52</p>  <p>x2</p>
<p>D</p>  <p>x8</p>	<p>R</p>  <p>x4</p>
<p>L2</p>  <p>4x16 mm.</p> <p>x4</p>	<p>N1</p>  <p>x2</p>
<p>L18</p>  <p>3,5x20 mm.</p> <p>x8</p>	<p>O2</p>  <p>x2</p>

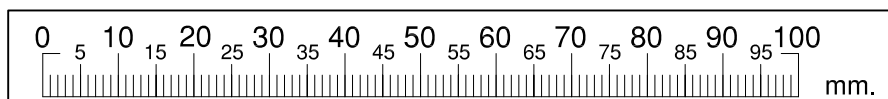

1

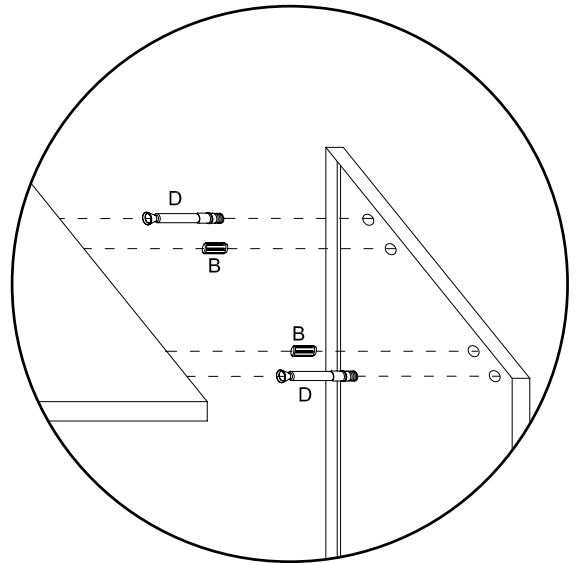
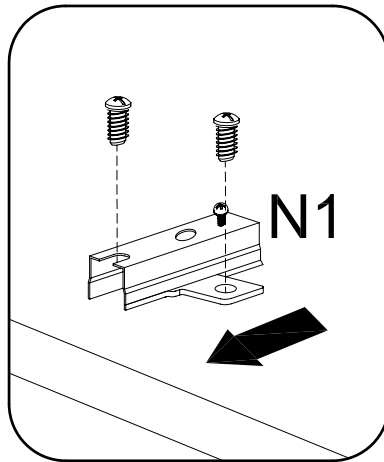
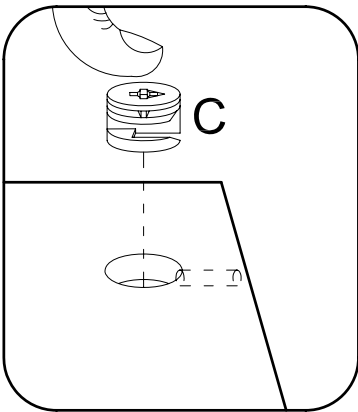
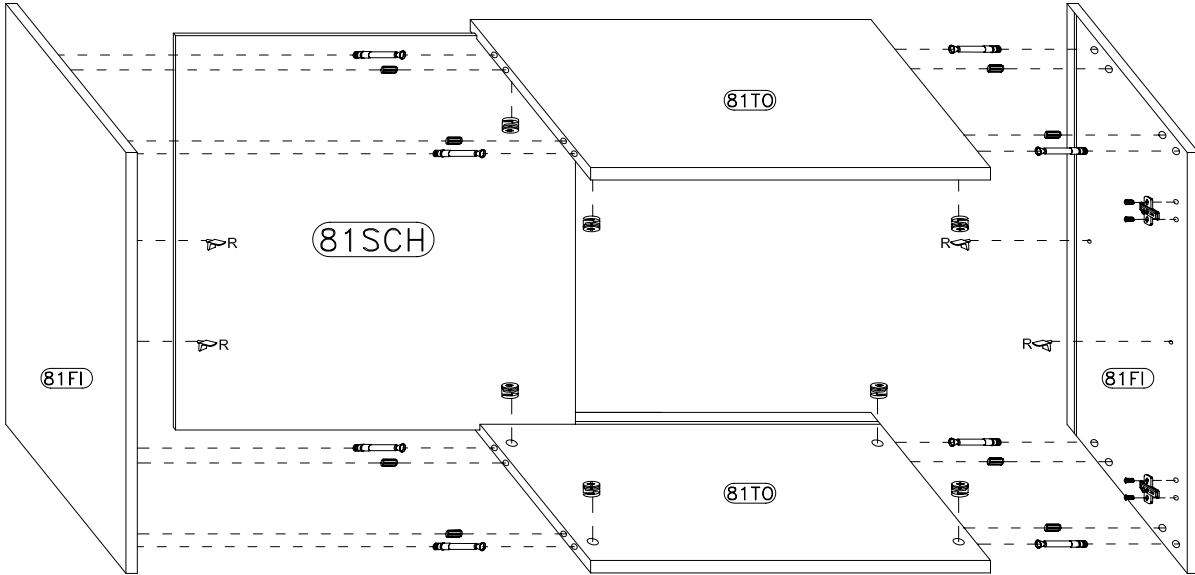
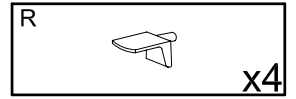
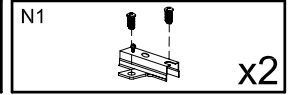
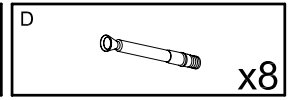
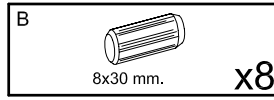
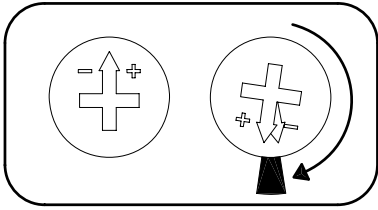

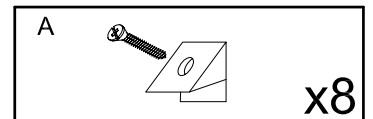
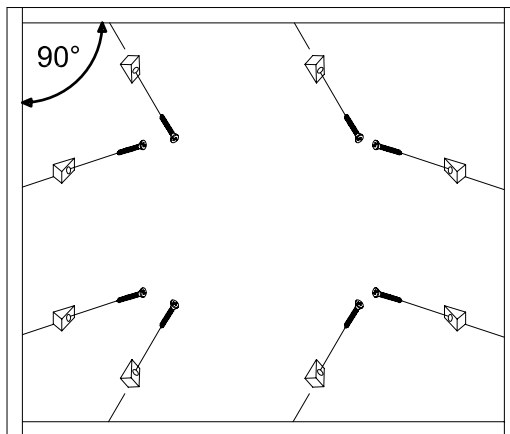
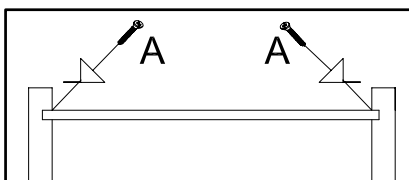

2



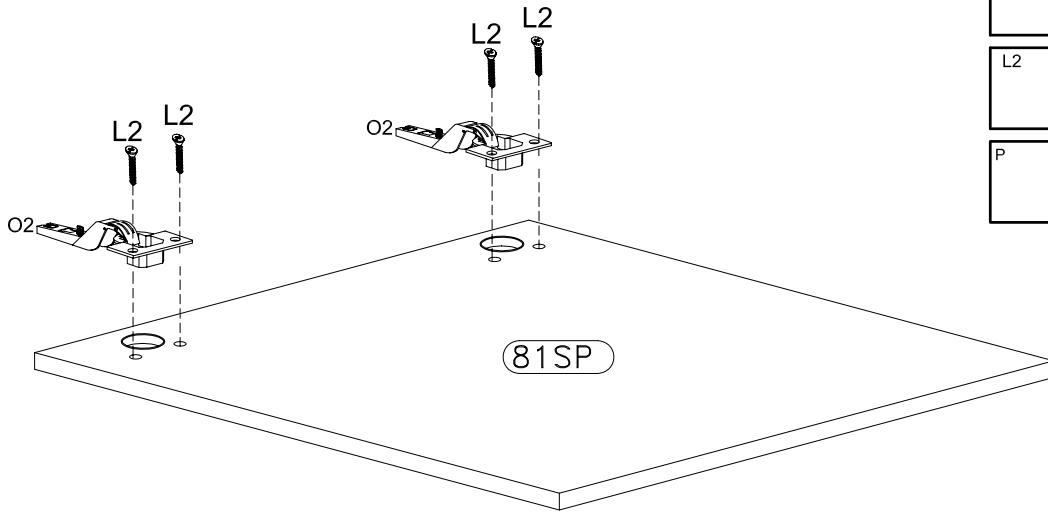

3

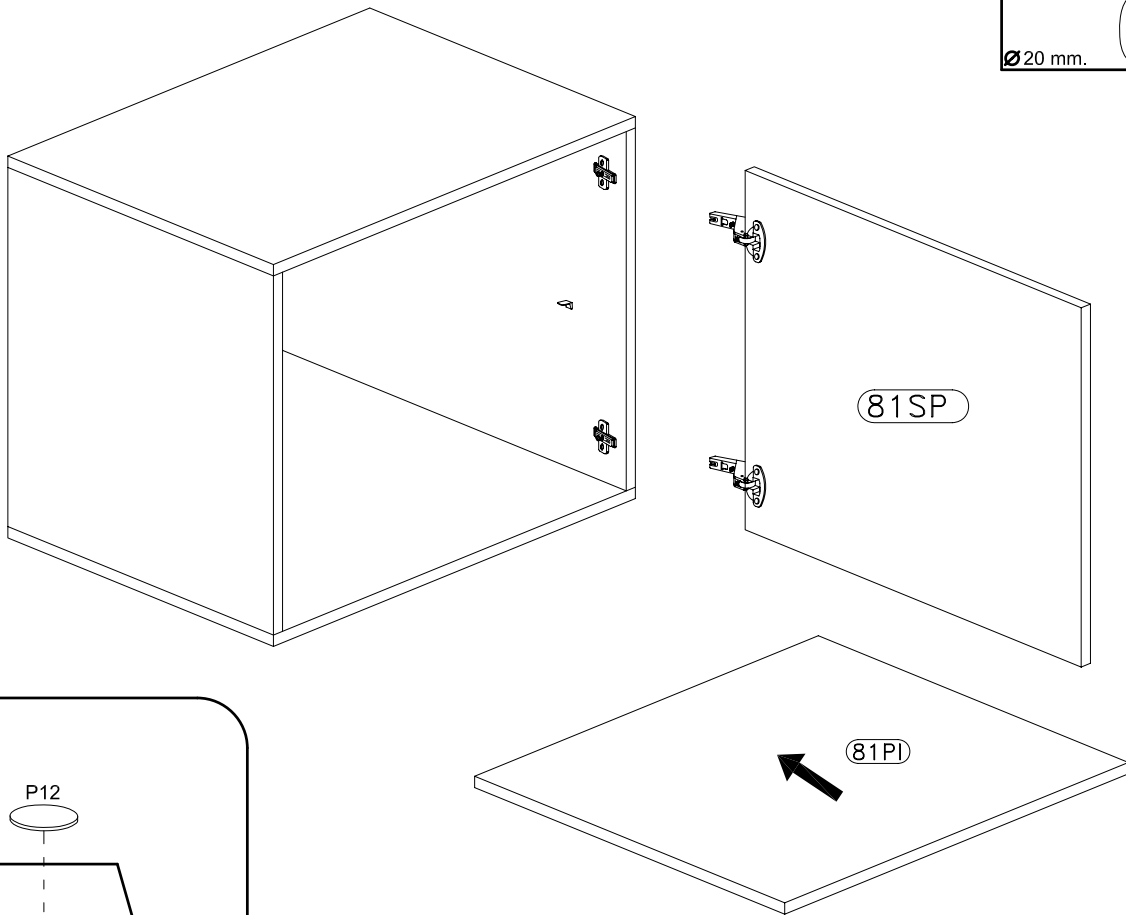

- O2  x2
- L2  4x16 mm. x4
- P  x2

4



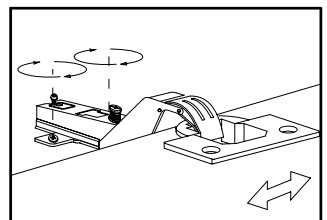
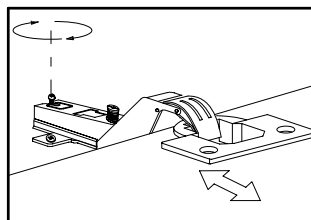
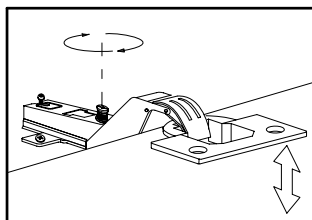
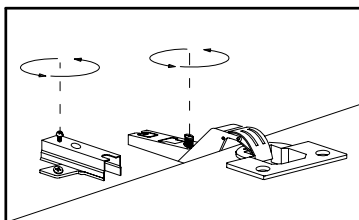
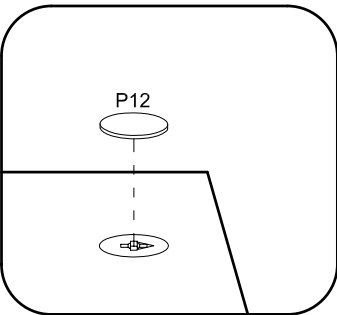

- P12   $\varnothing 20$  mm. x8

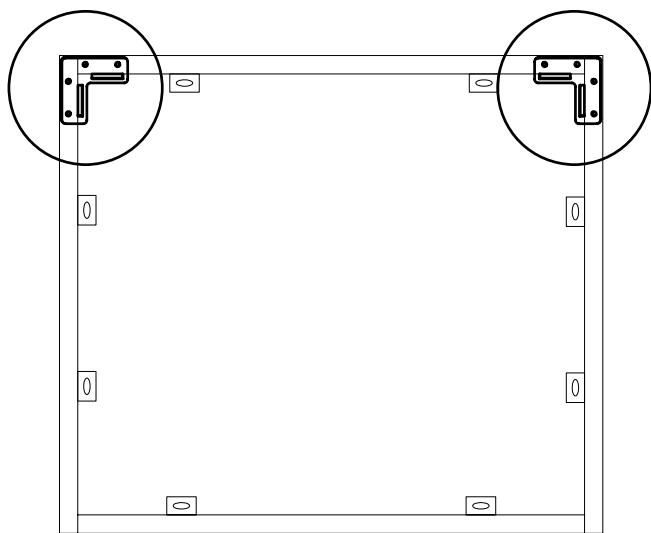

5

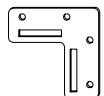

P52  x2

L18  3,5x20 mm. x8

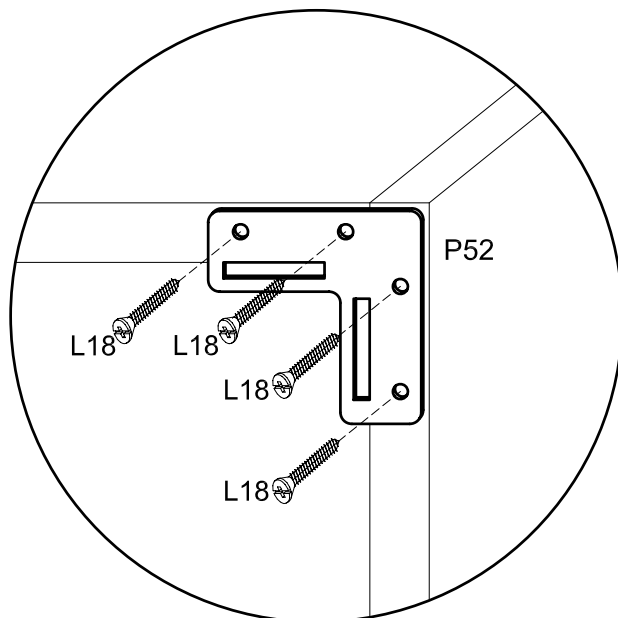

6

