

# MS25 Straight Desk

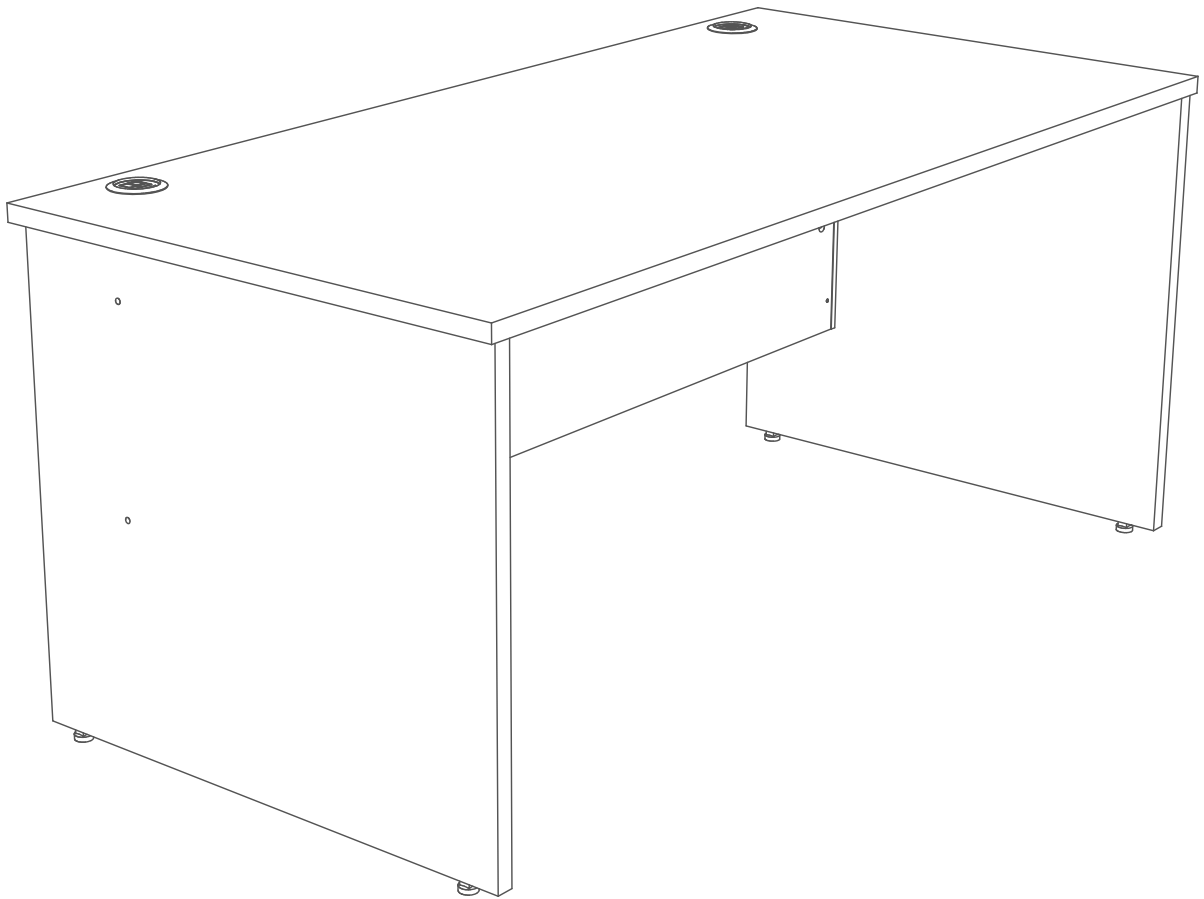

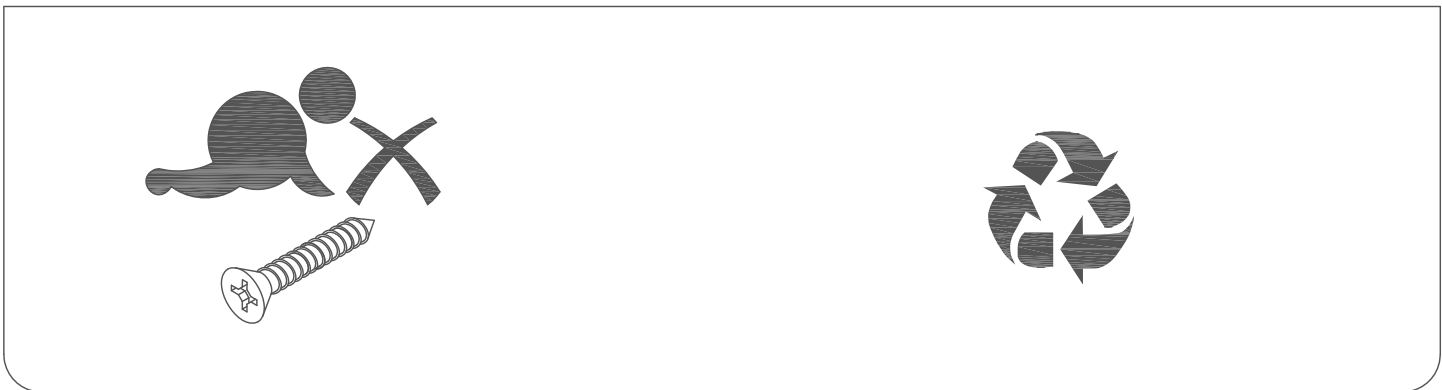

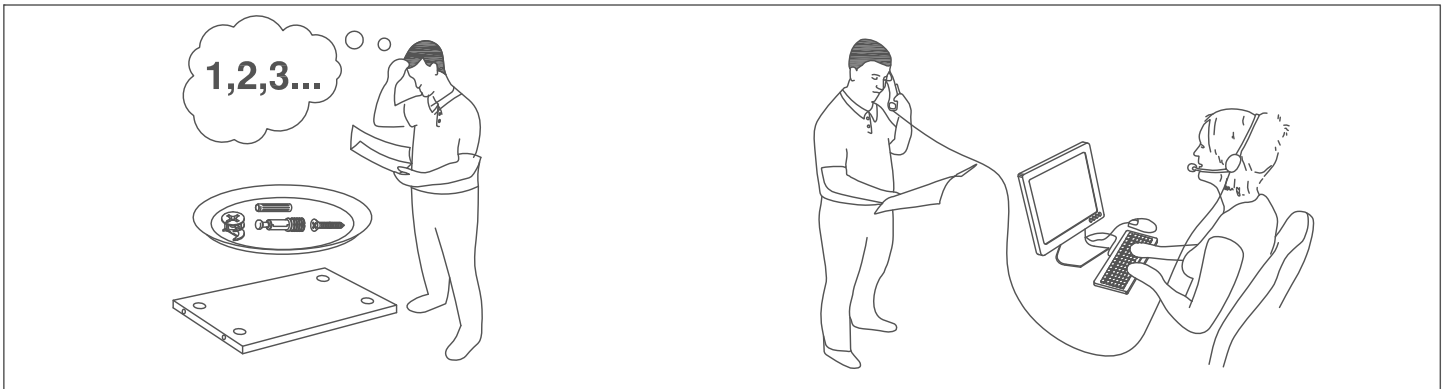
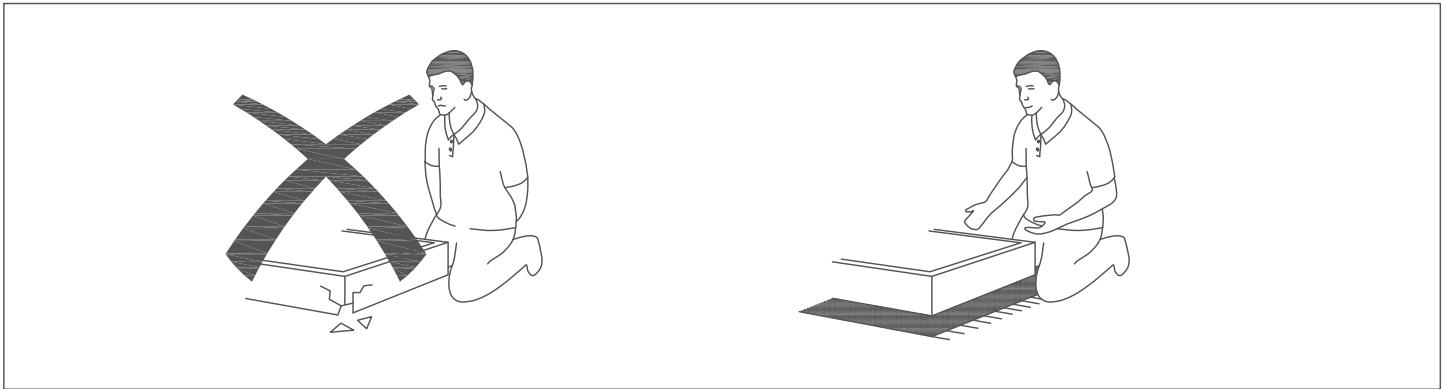
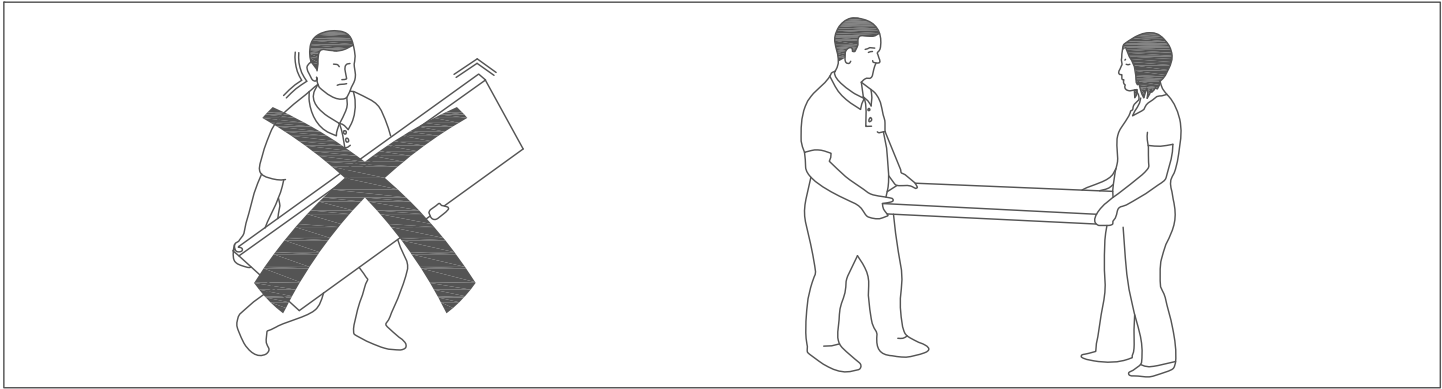
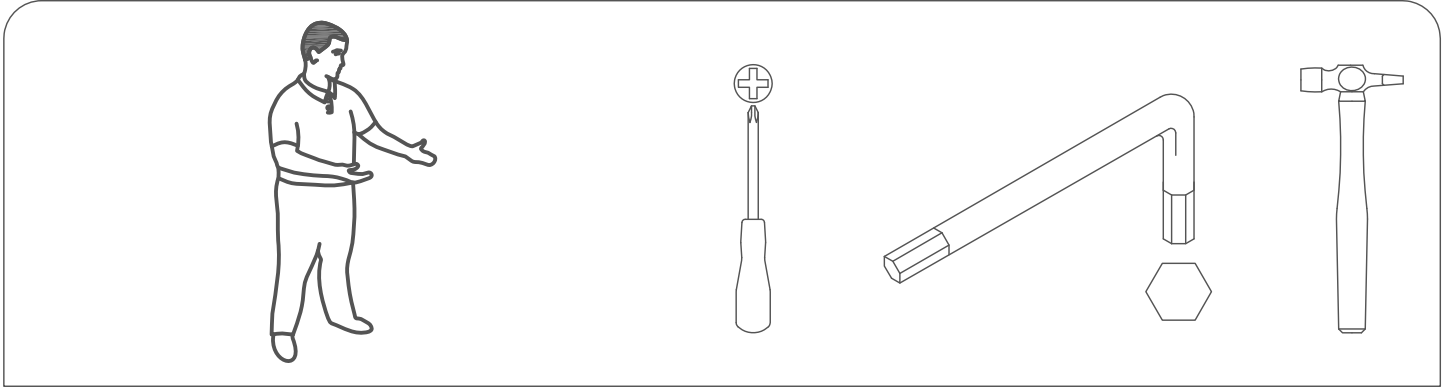

# Please check that you have all the fittings

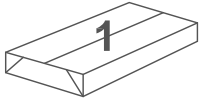

**MS25 LH**  
RM-LGP026

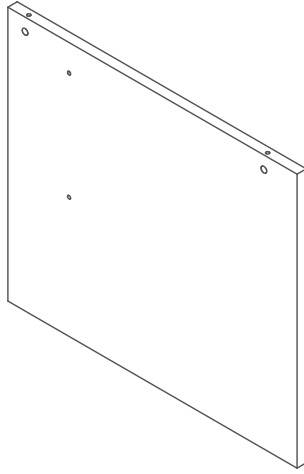
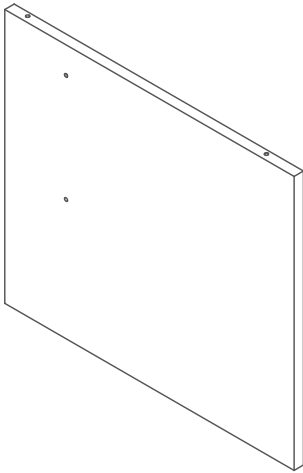

**MS25 RH**  
RM-LGP027



**MS25 BARS**  
RM-BARS28

**4** Confirmat screw 50mm (Black)  
RM-CFM01 

**4** Connect Bolt M6x35mm  
RM-BLT03 

**4** Mini fix bolt B34  
RM-BLT07 

**1** 4mm Allen key  
RM-ALK01 

**4** Gesipa M8 Blind Rivet Nut  
RM-NUT04 

**4** Adjustable Foot Dia 25mm  
RM-FRL19 

**4** Nylon M6x10 Socket  
RM-PAR05 

**4** Cam 15N  
RM-CAM03 

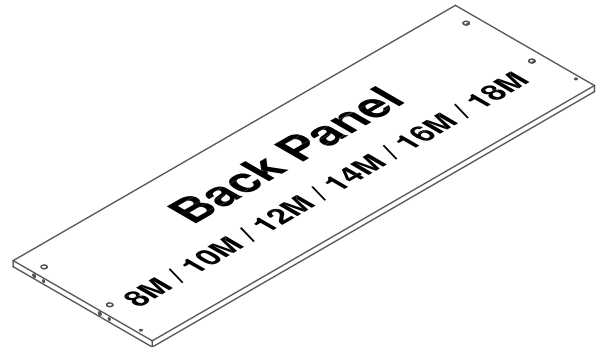
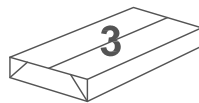
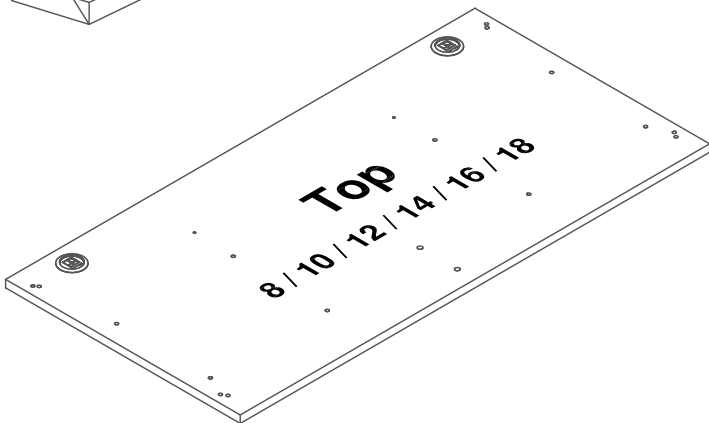
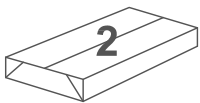

1

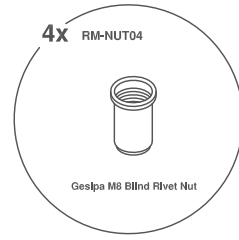
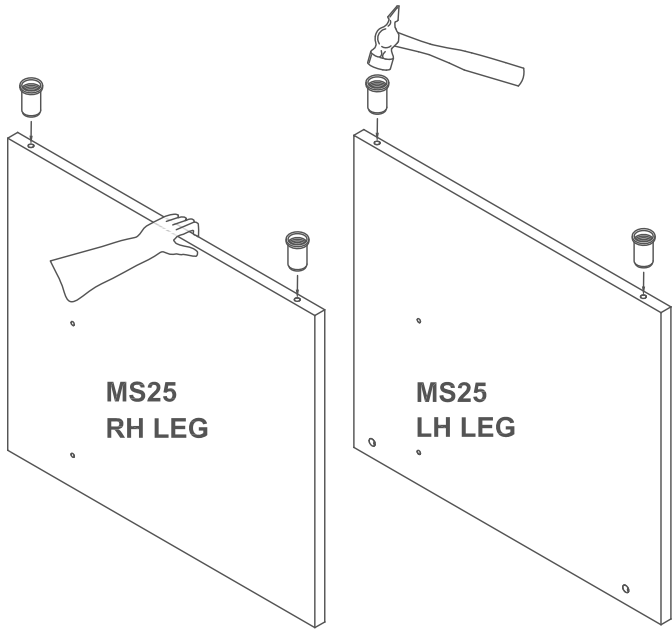

2

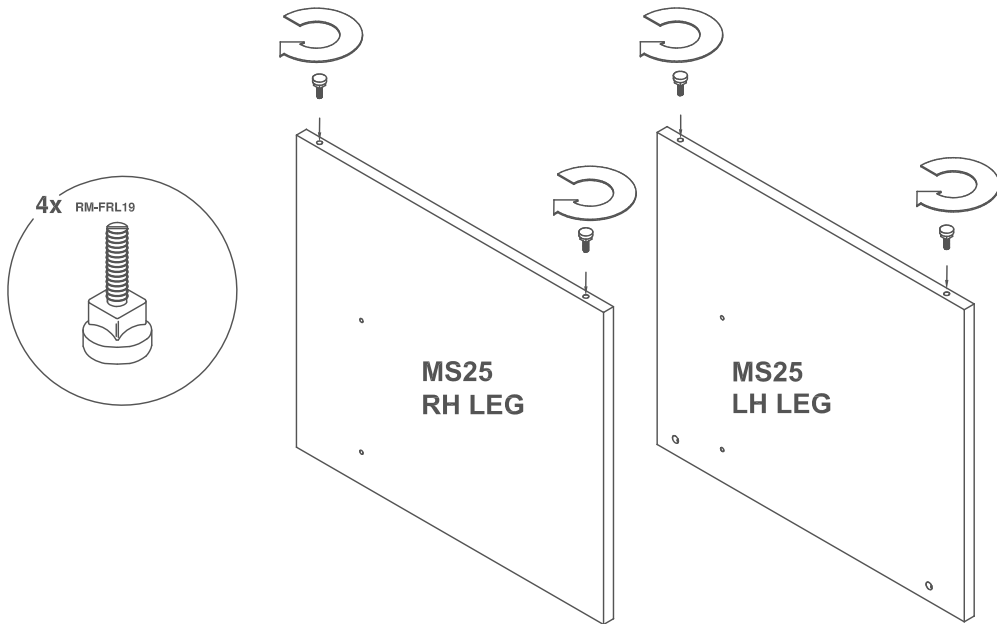

3

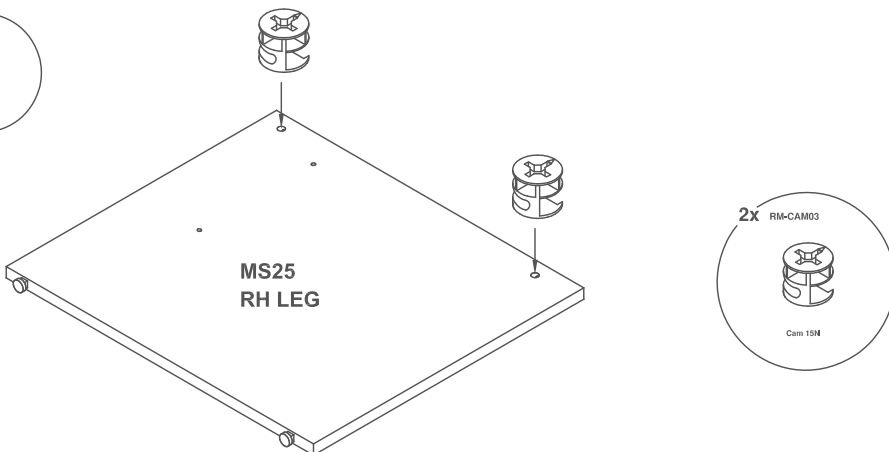

4

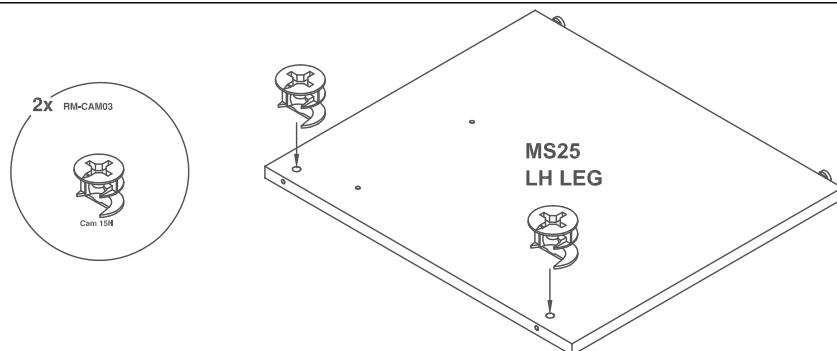

5

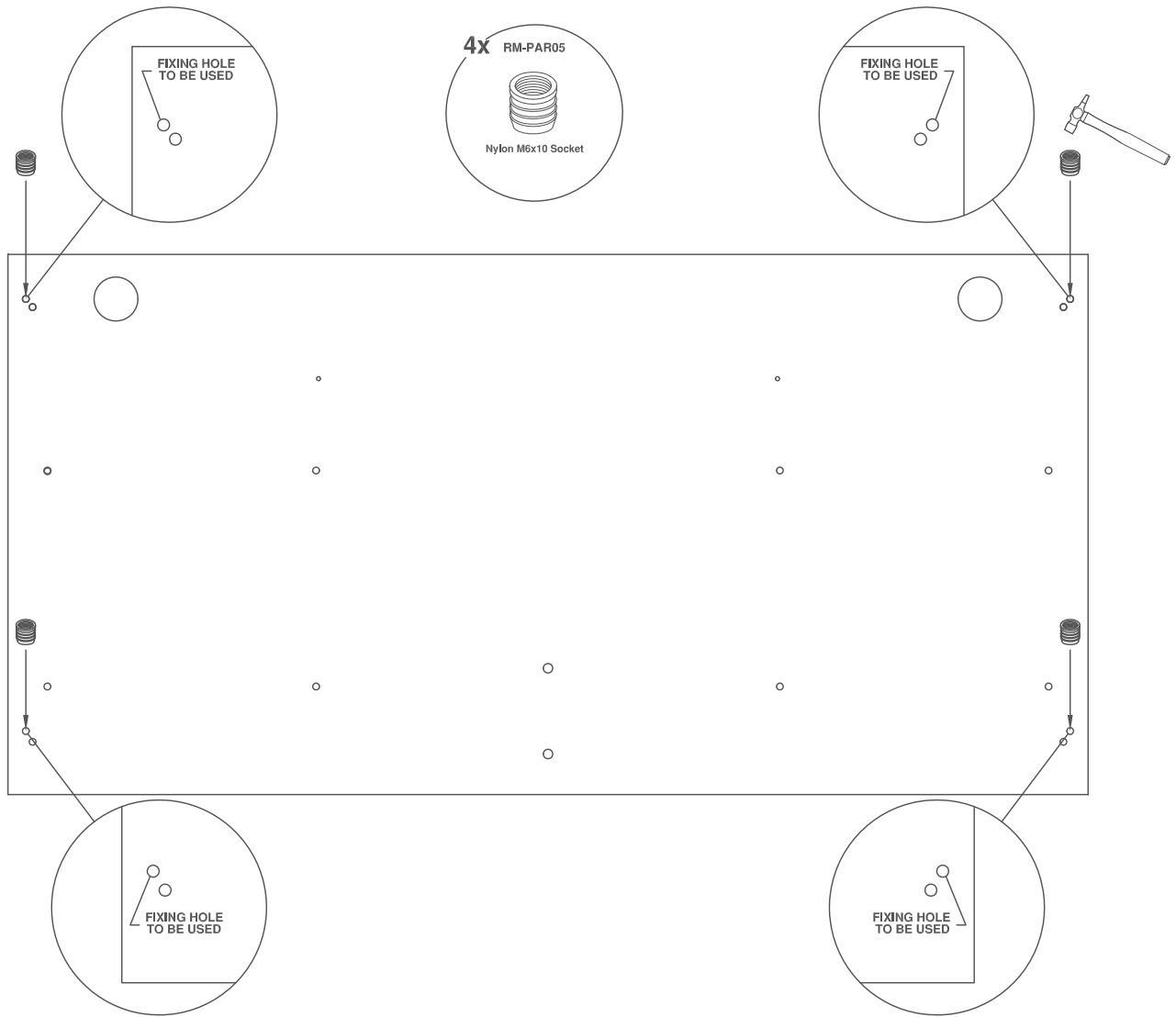

6

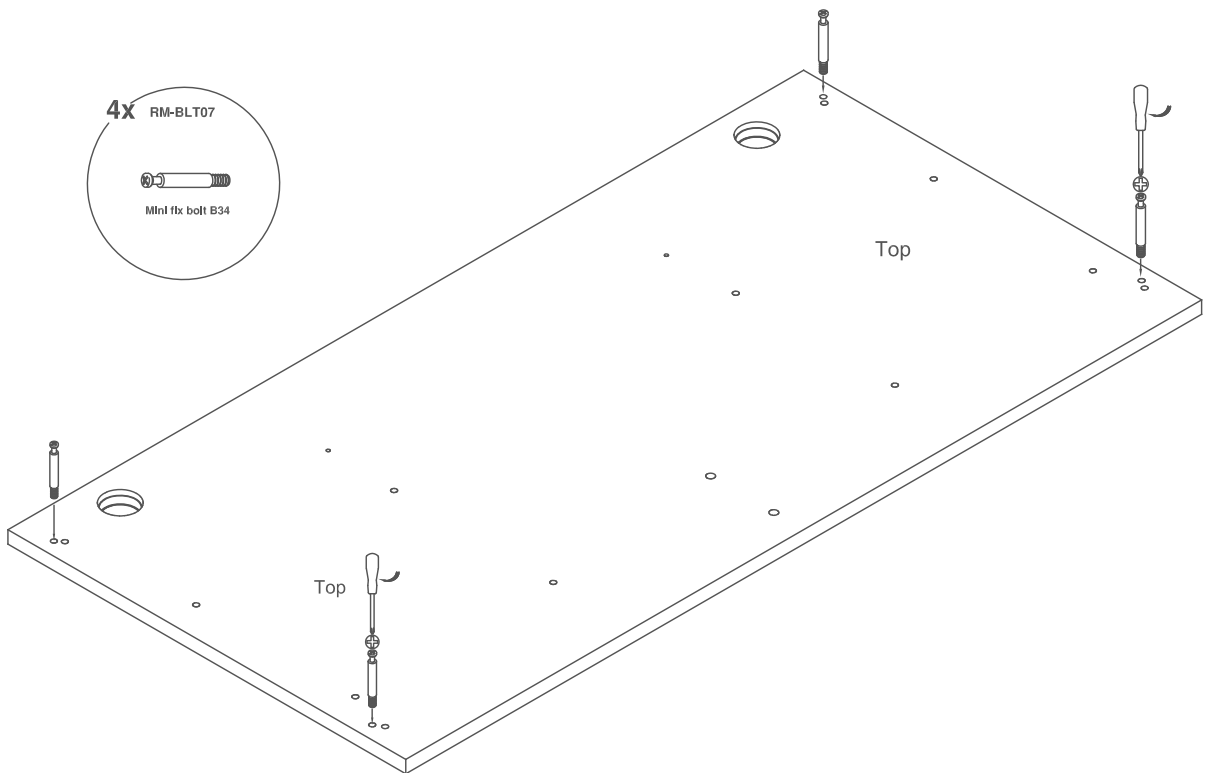

7

4x RM-CFM01



Conformat screw 50mm (Black)

MS25  
BAR

Back  
Panel

Side  
Elevation  
of  
Back  
Panel

Fixing  
Holes  
to be  
used

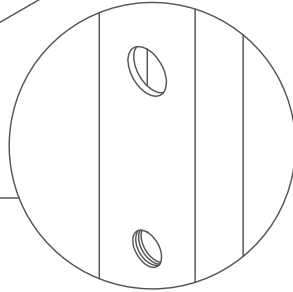
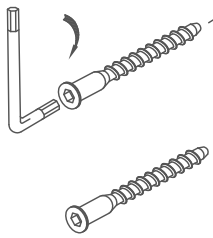

8

MS25  
RH LEG

2x

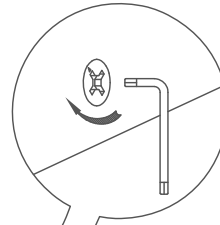

Make sure you turn the cams  
as far as they will easily go -  
more than half a turn.

Top

9

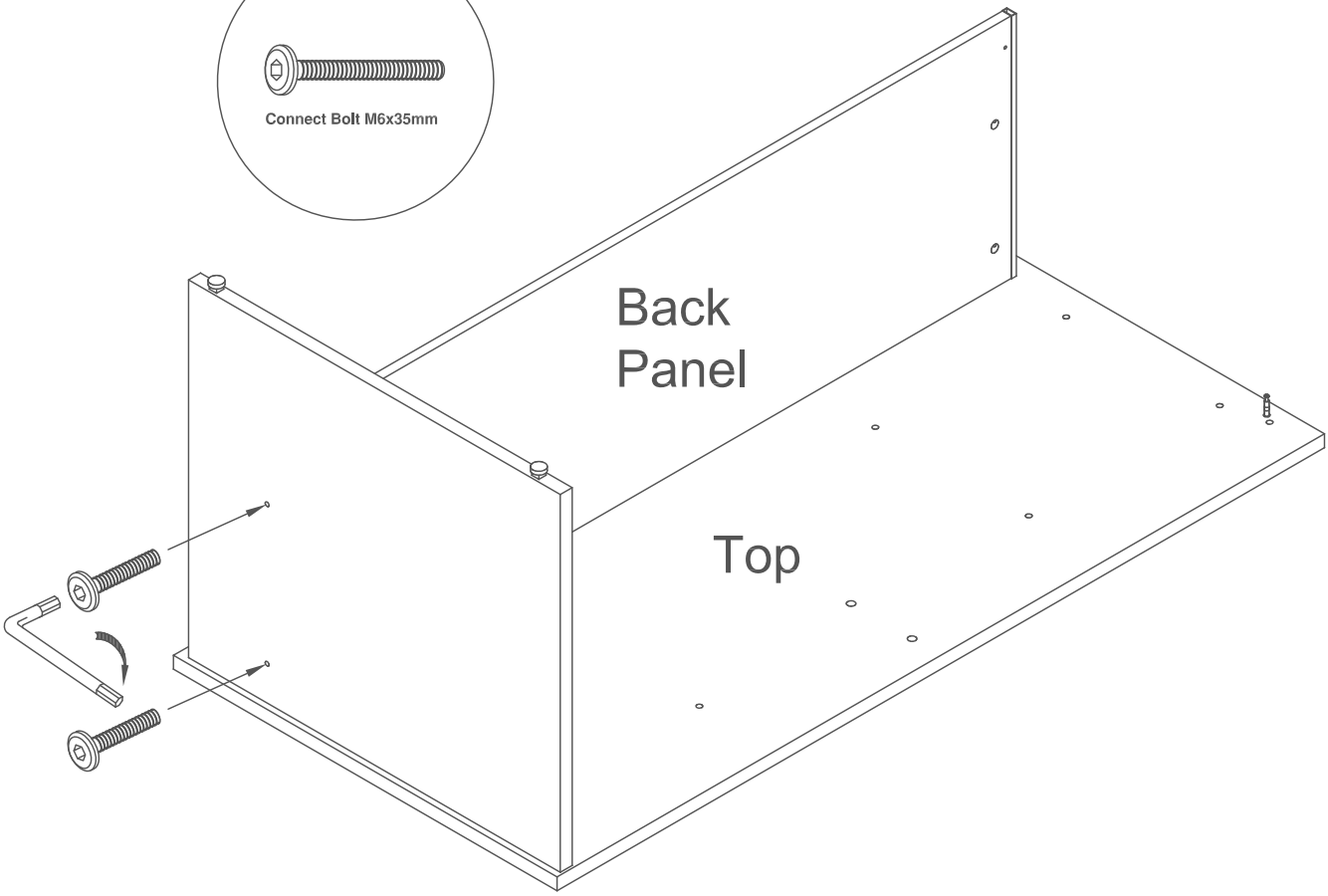
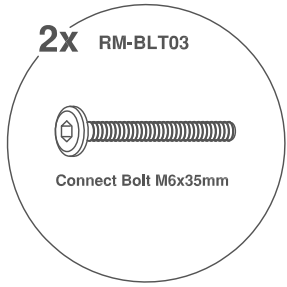

10

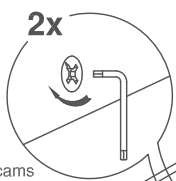

Make sure you turn the cams as far as they will easily go - more than half a turn.

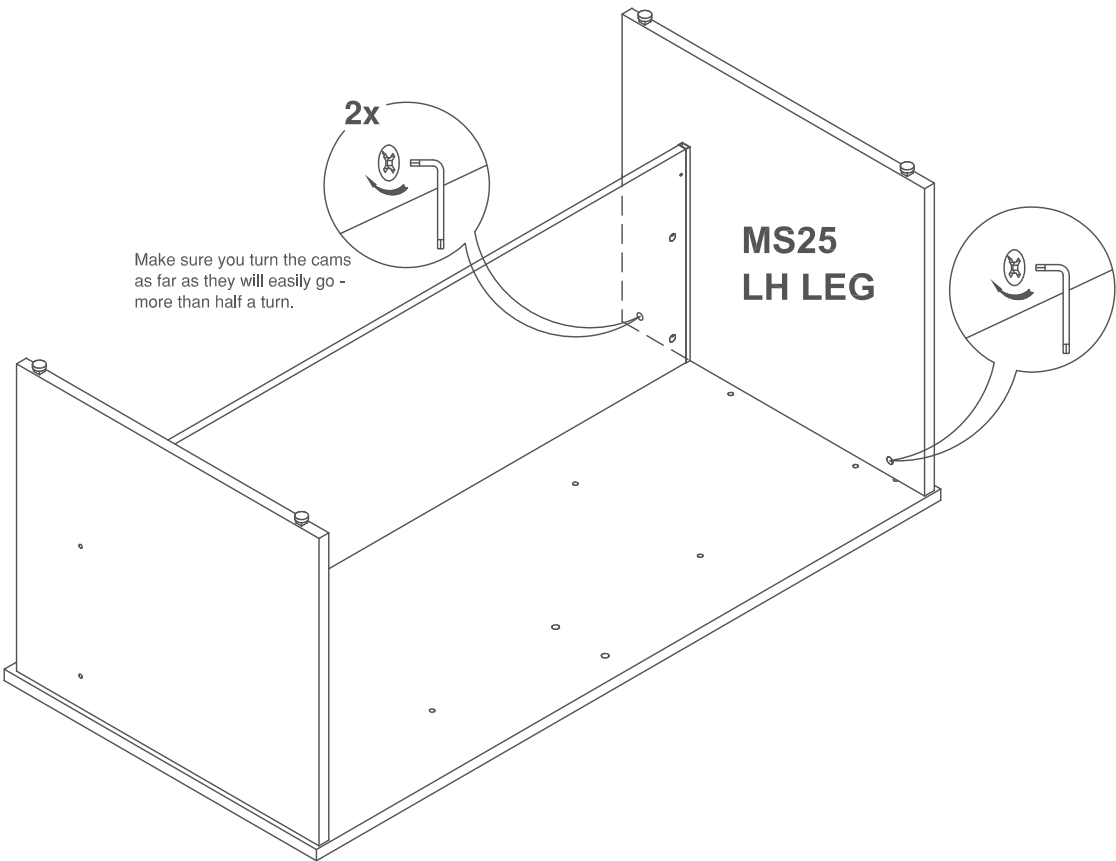

11

