

SECRET MAPLE & CHOCOLATE : ÉRABLE SECRET ET CHOCOLAT : ARCE SECRETO Y CHOCOLATE

BORDEAUX & GRAPHITE : BORDEAUX ET GRAPHITE : BURDEOS Y GRAFITO

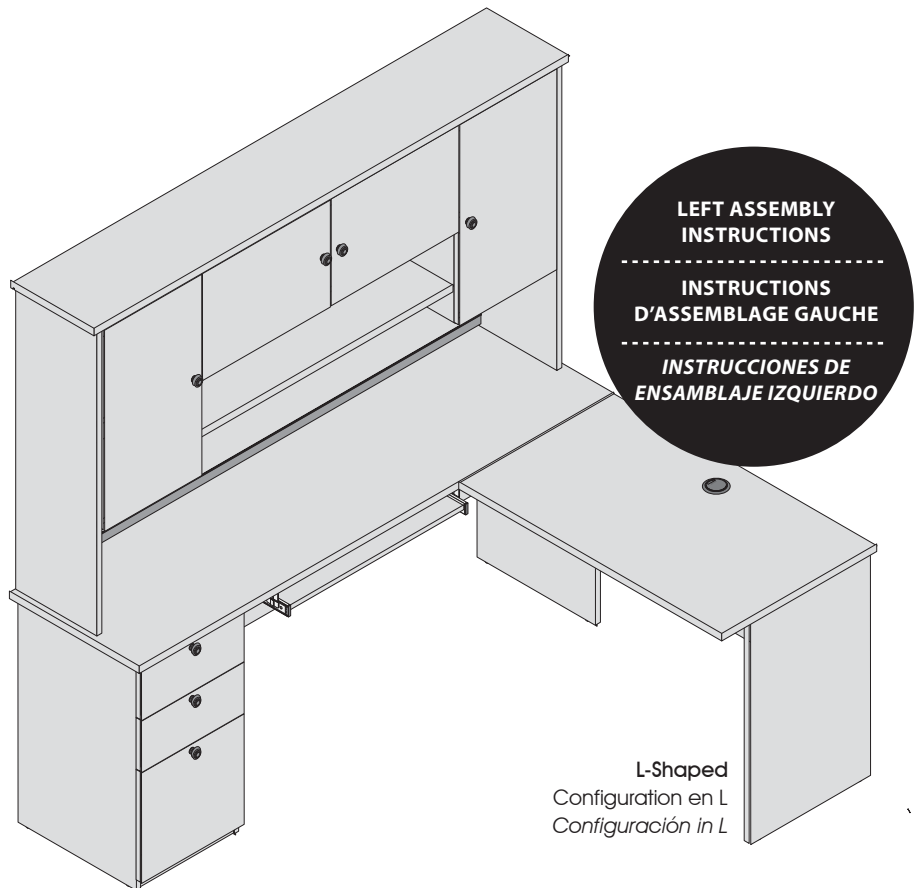





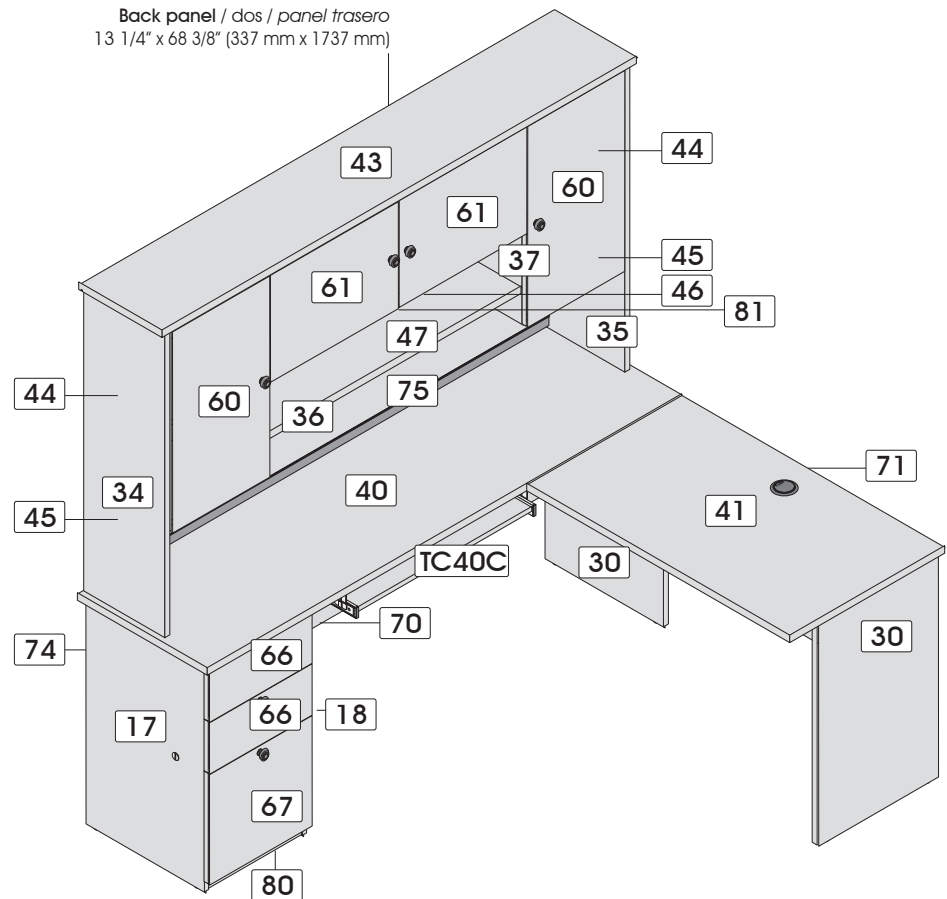











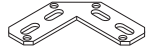
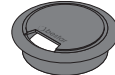



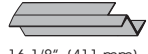
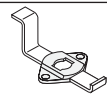

► PARTS / PIÈCES / PIEZAS



CODE / CÓDIGO	QTY / QTÉ / CANT.	CODE / CÓDIGO	QTY / QTÉ / CANT.	CODE / CÓDIGO	QTY / QTÉ / CANT.	CODE / CÓDIGO	QTY / QTÉ / CANT.
CA01A	4	34	1	45	2	71	1
CA05A	4	35	1	46	1	74	1
CA09A	2	36	1	47	1	75	1
CA13A	2	37	1	60	2	80	1
TC40C	1	40	1	61	2	81	1
17	1	41	1	66	2	Back panel / dos / panel trasero 13 1/4" x 68 3/8" (337 mm x 1737 mm)	1
18	1	43	1	67	1	Bottom / fond / fondo 12 7/16" x 15 3/8" (316 mm x 391 mm)	3
30	2	44	2	70	1		

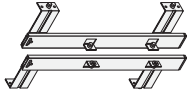
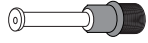

HARDWARES / QUINCAILLERIES / QUINCALLAS

CODE / CÓDIGO	QTY / QTÉ / CANT.	CODE / CÓDIGO	QTY / QTÉ / CANT.	CODE / CÓDIGO	QTY / QTÉ / CANT.	CODE / CÓDIGO	QTY / QTÉ / CANT.
AM-182  1/16" (2 mm)	4	CR-141 	2	PA-844 	8	VF-232  7/8" (22 mm)	7
CA-77 	6	EC-744 	6	PF-106 	1	VM-601  3/4" (20 mm)	6
CA-99 	35	EQ-143 	2	PF-108 	1	VR-207  1/2" (13 mm)	24
CH-840 	8	EX-681  11 7/8" (303 mm)	2	PO-777 	7	VR-212  1" (25 mm)	34
CL-140 	-	EX-702  16 1/8" (411 mm)	2	SE-686 	1		
CL-745 	1	EX-766 	1	TI-365 	4		
CO-249 runners 406 mm (16") coulisseaux 406 mm correderas 406 mm	3	H-03 	58	TI-552 	5		
CO-843 	1	H-36 	56	VE-244  3/8" (10 mm)	18		

REAL SIZE / GRANDEUR RÉELLE / TAMAÑO REAL

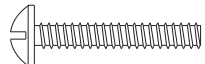
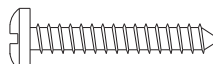
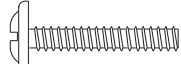
CODE / CÓDIGO	QTY / QTÉ / CANT.	CODE / CÓDIGO	QTY / QTÉ / CANT.
VE-244  3/8" (10 mm)	18	VR-207  1/2" (13 mm)	24
VF-232  7/8" (22 mm)	7	VR-212  1" (25 mm)	34
VM-601  3/4" (20 mm)	6		

PROBLEMS OR INFORMATION

POUR TOUT PROBLÈME OU INFORMATION
PROBLEMAS O INFORMACIÓN

▶ IMPORTANT NOTICE / NOTE IMPORTANTE / NOTA IMPORTANTE

Duly complete the self-adhesive sticker. / Assurez-vous de bien remplir l'auto-collant. / Asegúrese de completar correctamente la etiqueta.

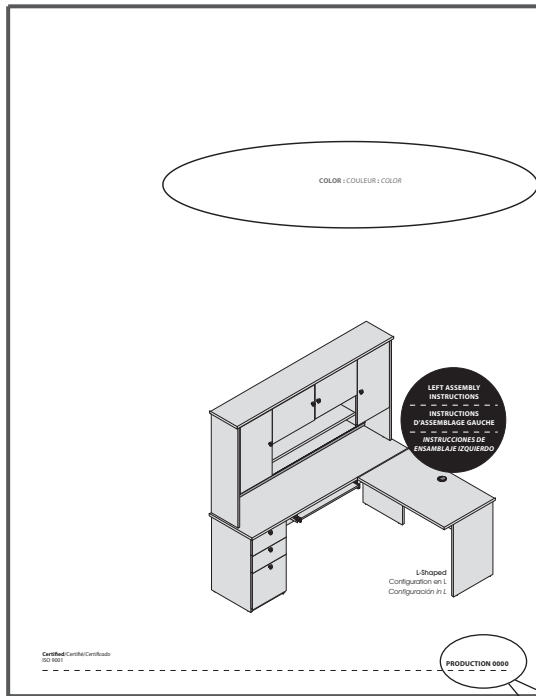

Model / Modèle: _____

Production Number
Numéro de production: _____

PRODUCTION 0000

Important/Importante

Please retain the self-adhesive sticker which you will install at page 25 of the instruction manual.

Conservez l'autocollant qui sera collé seulement à la page 25 du feuillet d'instructions.

Conserve la etiqueta que será pegada sólo en la página 25 de la hoja de instrucciones.

IMPORTANT NOTICE / NOTE IMPORTANTE / NOTA IMPORTANTE

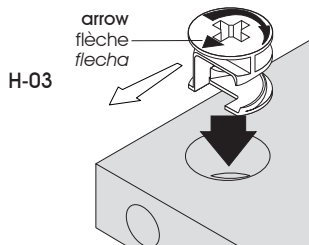

H-03

Insert the cam with the arrow pointing towards the hole in the edge.

Insérez la rondelle en pointant la flèche vers le trou de la bordure.

Inserte la arandela con la flecha apuntando hacia el orificio cercano al borde.

Main hardware system / Système de quincaillerie principal / Sistema principal de quincalla

1

insert
insérez
insertar

2

tools required
outils requis
herramientas necesarias

tighten
serrez
apretar

3

important
importante

How to remove a misplaced assembly bolt (H-36).
Comment retirer un boulon (H-36) mal situé.
Cómo retirar un perno (H-36) mal ubicado.

A

turn
tournez
haga girar

B

pull out
retirez

Credenza / Crédence / Credencia

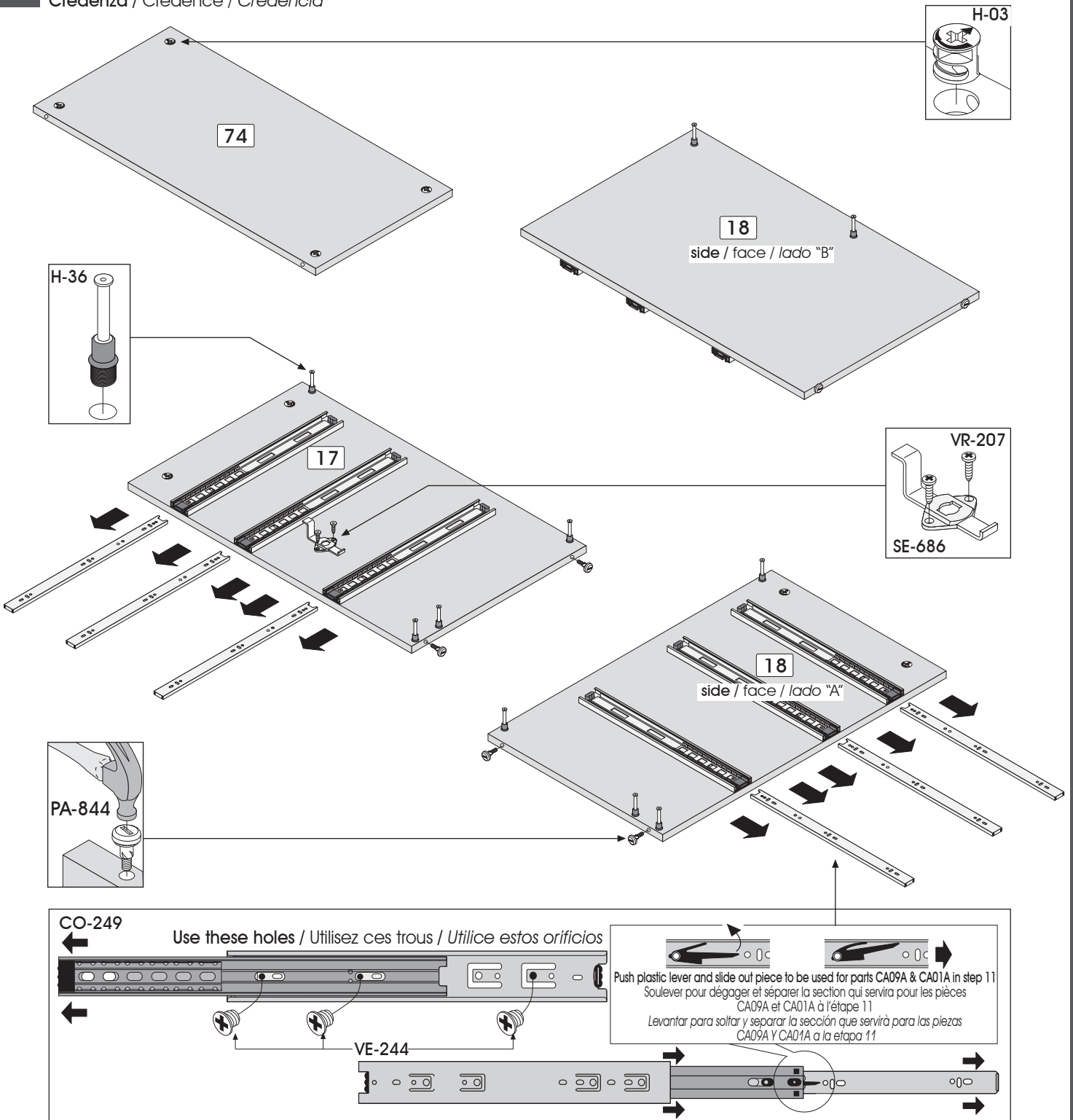

1							
Code / Código	CO-249	H-03	H-36	PA-844	SE-686	VR-207	VE-244
Qty / Qté / Cant.	x 3	x 8	x 10	x 4	x 1	x 2	x 18

2 HARDWARE INSTALLATION / INSTALLATION DES QUINCAILLERIES / INSTALACIÓN DE LAS QUINCALLAS

Credenza / Crédence / Credencia

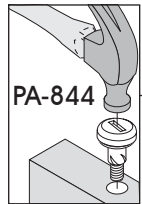
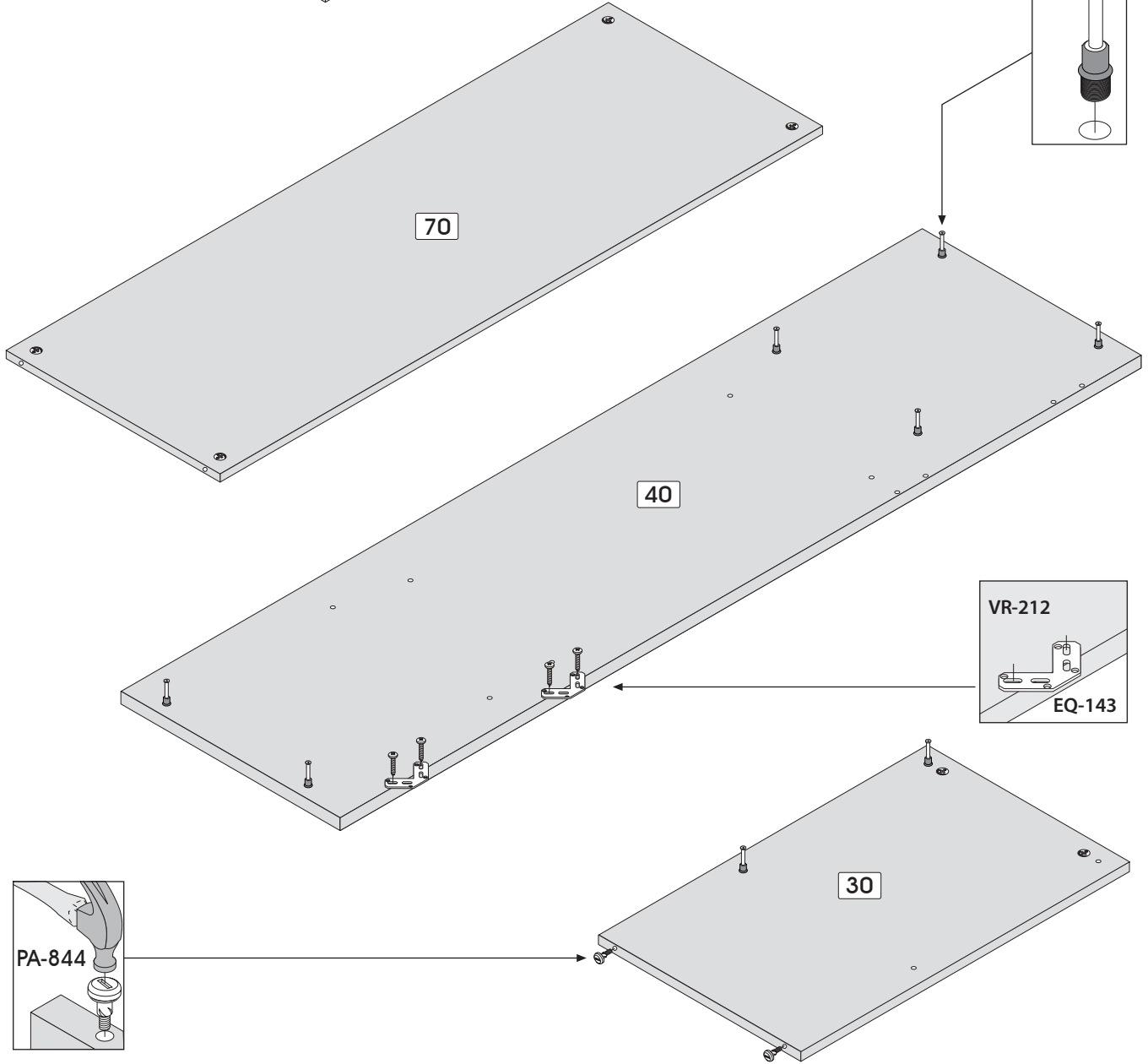
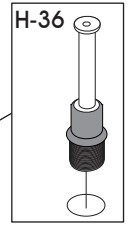
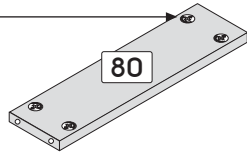
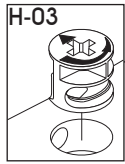

2



H-03

x 10

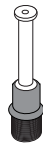

H-36

x 8



PA-844

x 2

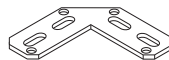

EQ-143

x 2



VR-212

x 4

Code / Código

Qty / Qté / Cant.

IMPORTANT NOTICE / NOTE IMPORTANTE / NOTA IMPORTANTE

▶ Main hardware system / Système de quincaillerie principal / Sistema principal de quincalla

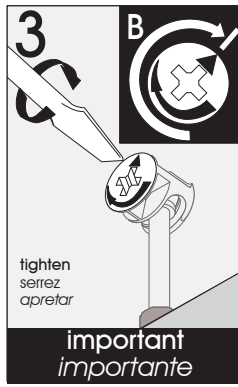
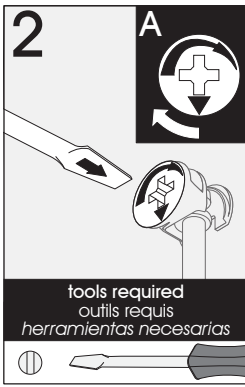
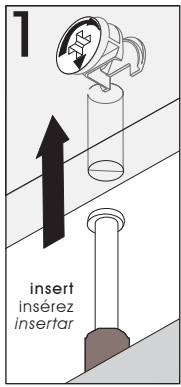

Make sure to properly tighten each cam to ensure furniture solidity. Otherwise, parts could be damaged or the user could be injured.

Assurez-vous de bien resserrer chaque rondelle pour assurer la solidité du meuble. Dans le cas contraire, des pièces pourraient être endommagées ou l'utilisateur pourrait se blesser.

Asegúrese de apretar bien cada arandela para garantizar la solidez del mueble. De lo contrario, podría provocarse daño a las piezas o las personas.

3 ASSEMBLY / ASSEMBLAGE / ENSAMBLAJE

Credenza / Crédence / Credencia

Assemble upside down

Assemblez en position renversée

Realice el ensamblaje en posición invertida

Assembling sequence

Séquence d'assemblage

Secuencia de ensamblaje

Parts / Pièces / Piezas:

17 74 80 18 70 30 40



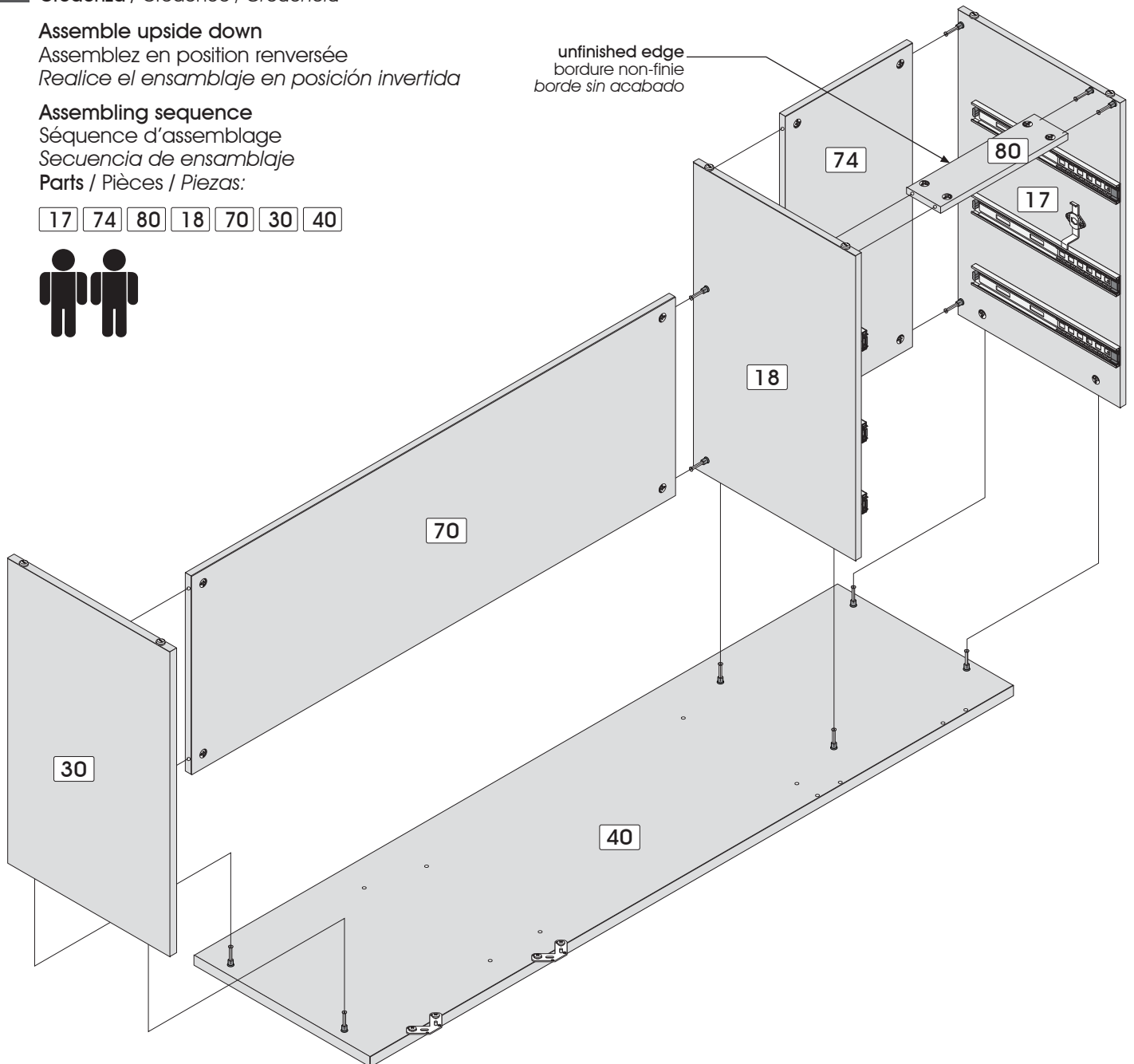

unfinished edge
bordure non-finie
borde sin acabado

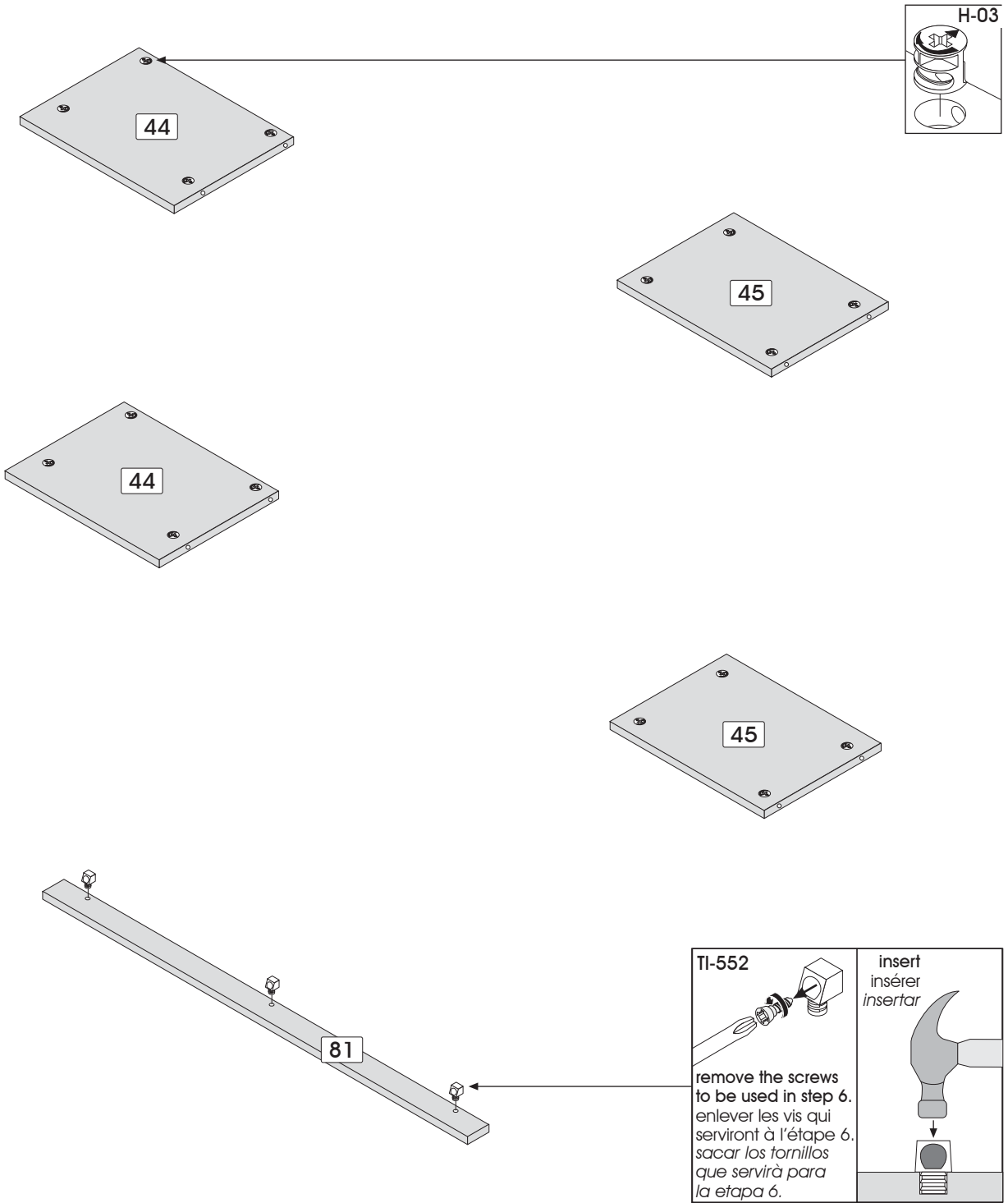

Hutch / Étagère / Estantería



4

Code / Código	 H-03	 TI-552
Qty / Qté / Cant.	x 16	x 3

Hutch / Étagère / Estantería

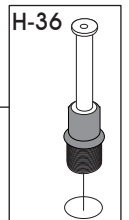
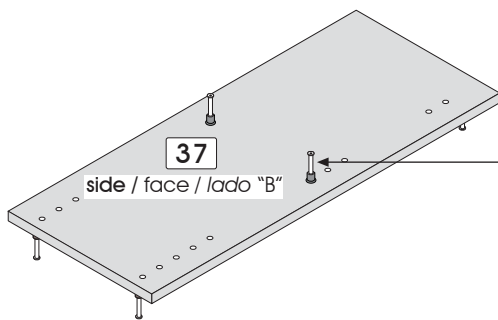
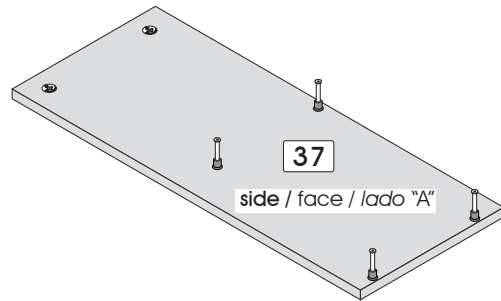
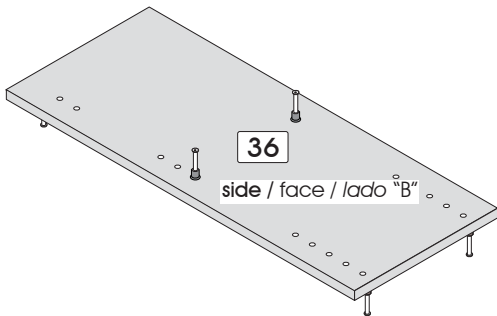
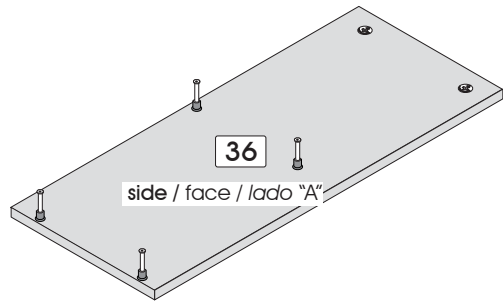
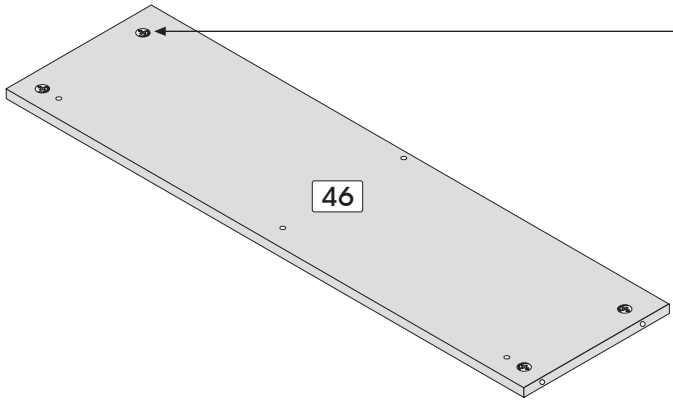
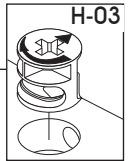

5



H-03

x 8

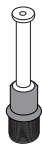

H-36

x 12

Code / Código

Qty / Qté / Cant.

Assemble on the front edge
 Assemblez sur la bordure avant
 Realice el ensamblaje sobre el borde delantero

Assembling sequence
 Séquence d'assemblage
 Secuencia de ensamblaje

Parts / Pièces / Piezas:

46 37 36 44 44 45 45 81

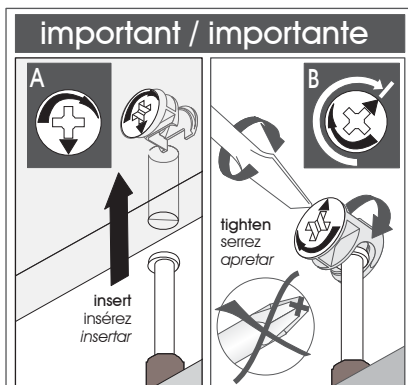
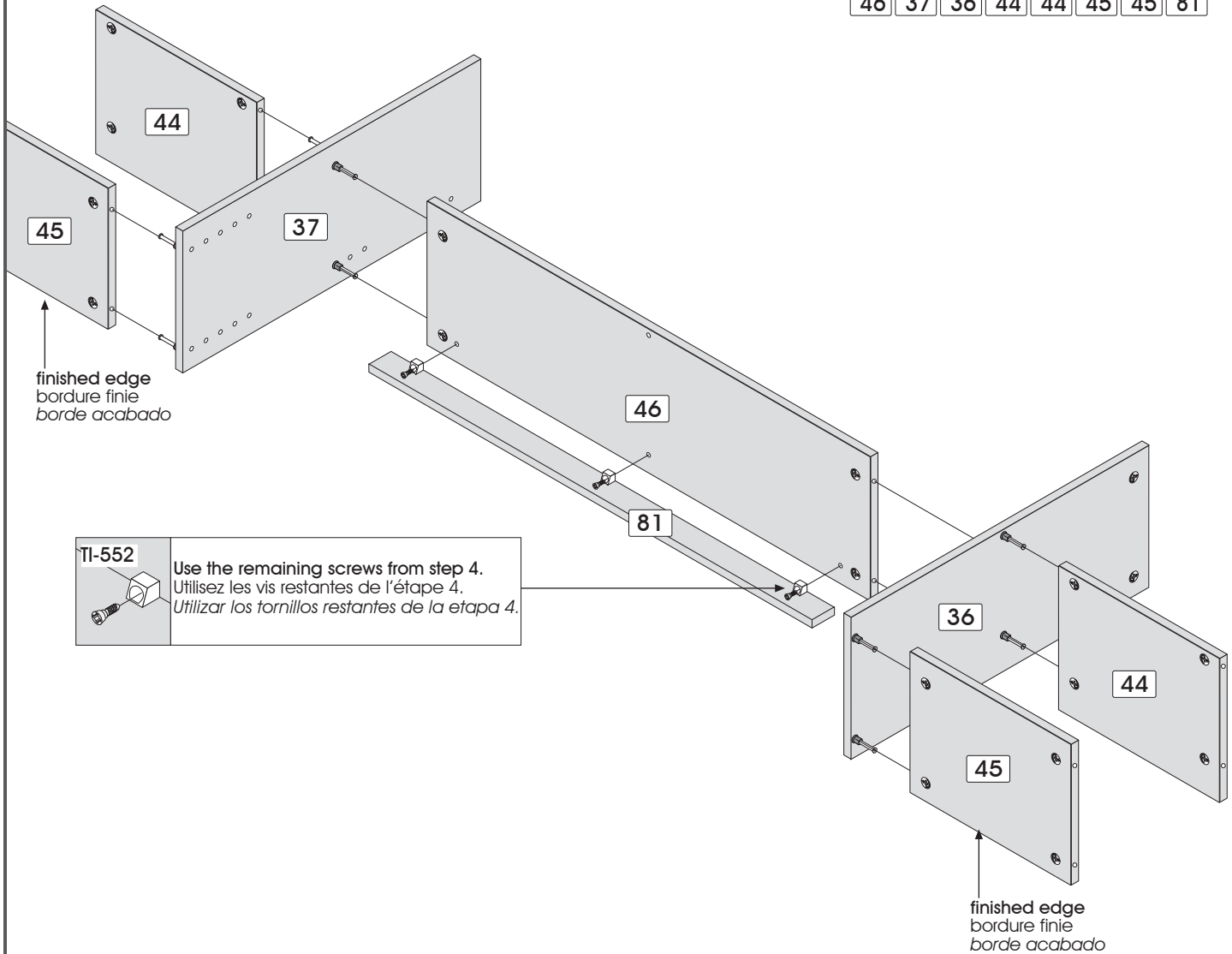

Hutch / Étagère / Estantería

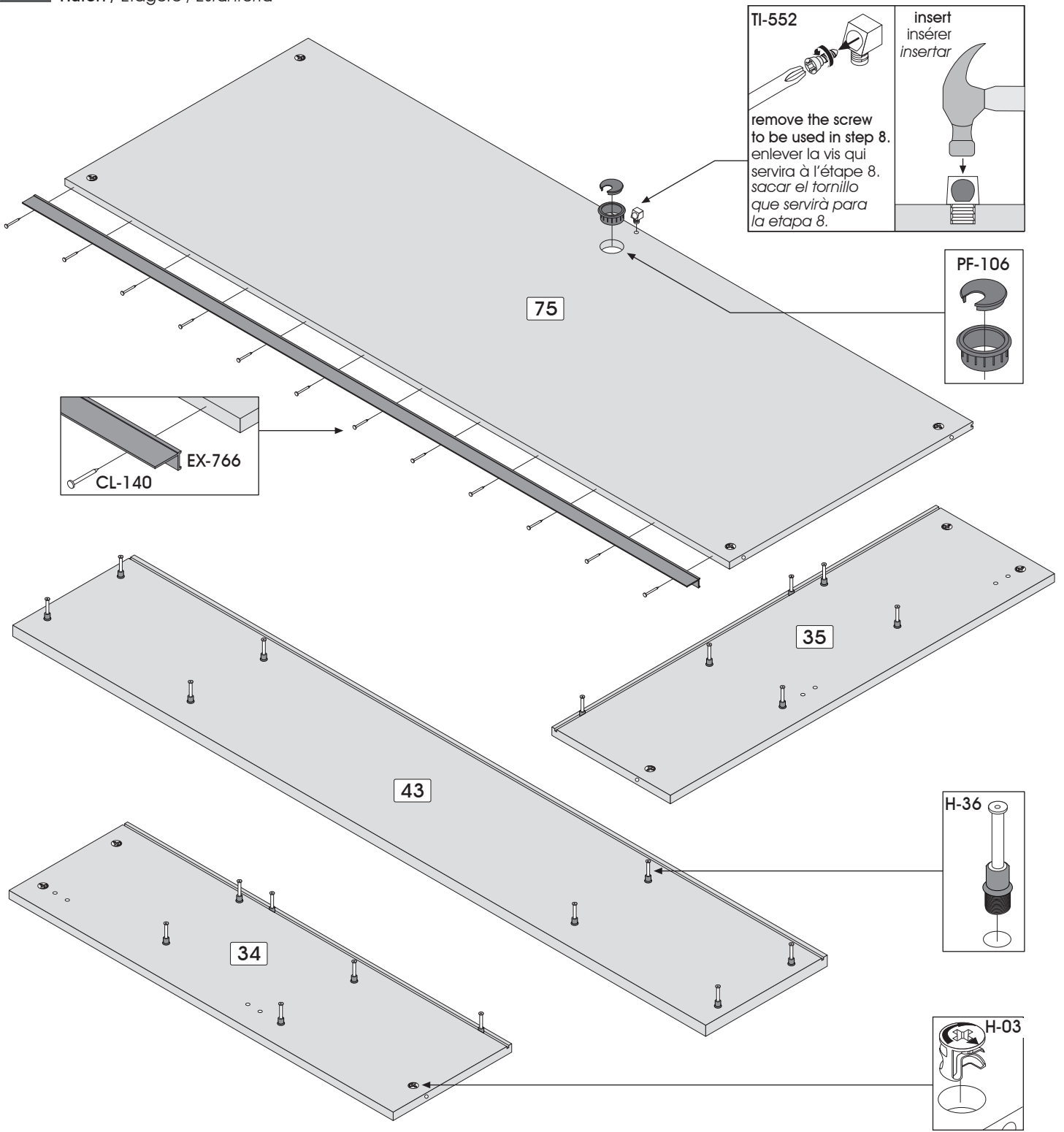

Code / Código	H-03	H-36	TI-552	PF-106	EX-766	CL-140
Qty / Qté / Cant.	x 10	x 20	x 1	x 1	x 1	-

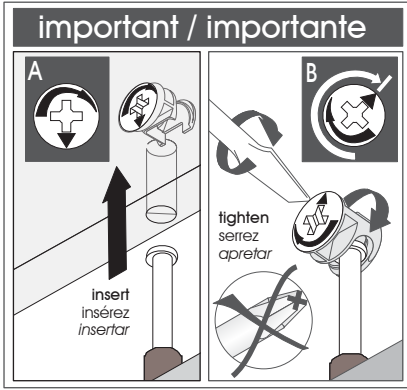

Assemble on the back edge
 Assemblez sur la bordure arrière
 Realice el ensamblaje sobre el borde trasero

Assembling sequence
 Séquence d'assemblage
 Secuencia de ensamblaje
 Parts / Pièces / Piezas:

75 34 + 44 45 36 37 45 44
 + 35 + back panel / dos / panel trasero + 43

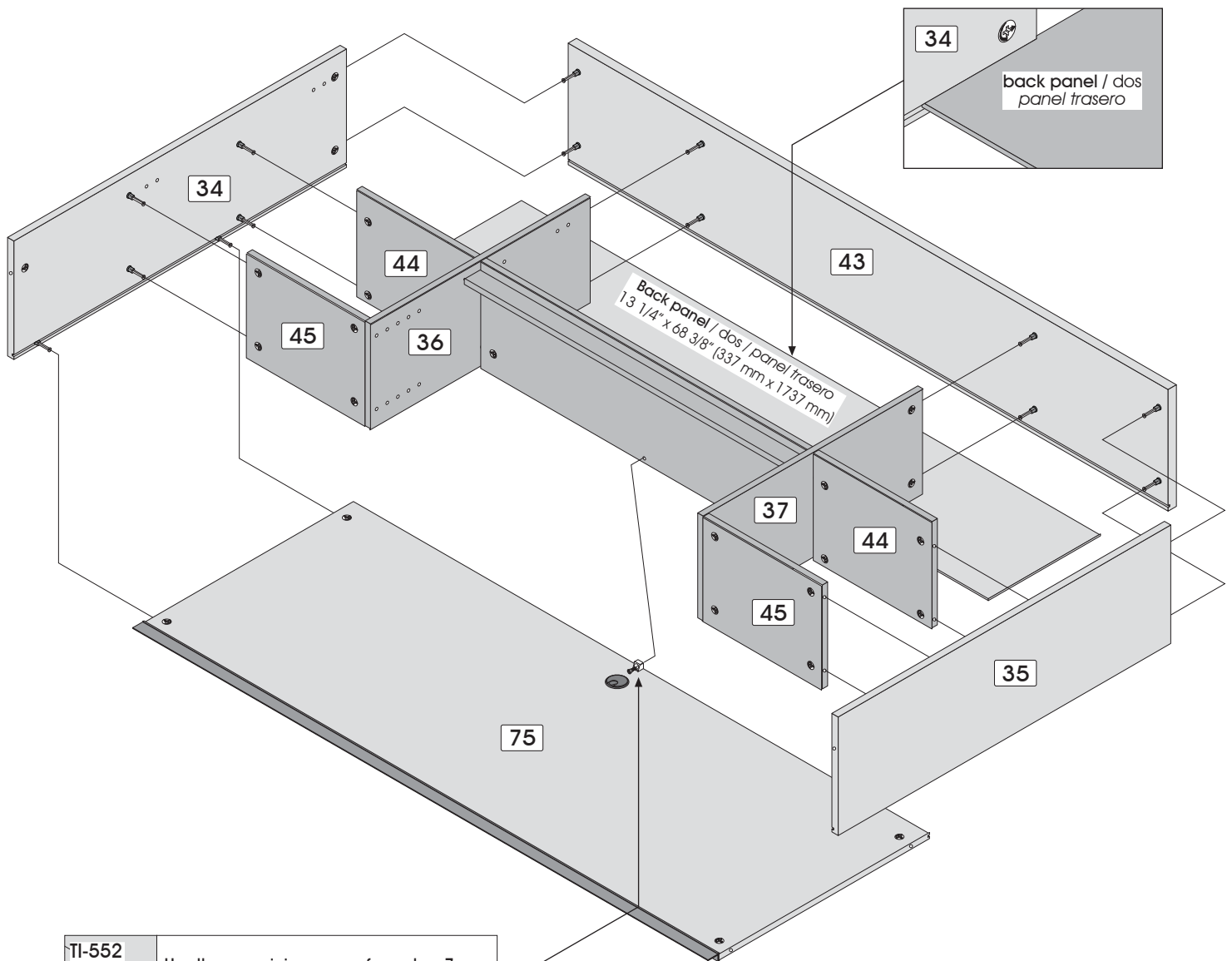

TI-552



Use the remaining screw from step 7.
 Utilisez la vis restante de l'étape 7.
 Utilizar el tornillo restante de la etapa 7.

Hutch / Étagère / Estantería

Assembling sequence
 Séquence d'assemblage
 Secuencia de ensamblaje
 Parts / Pièces / Piezas:

40 + 34 35

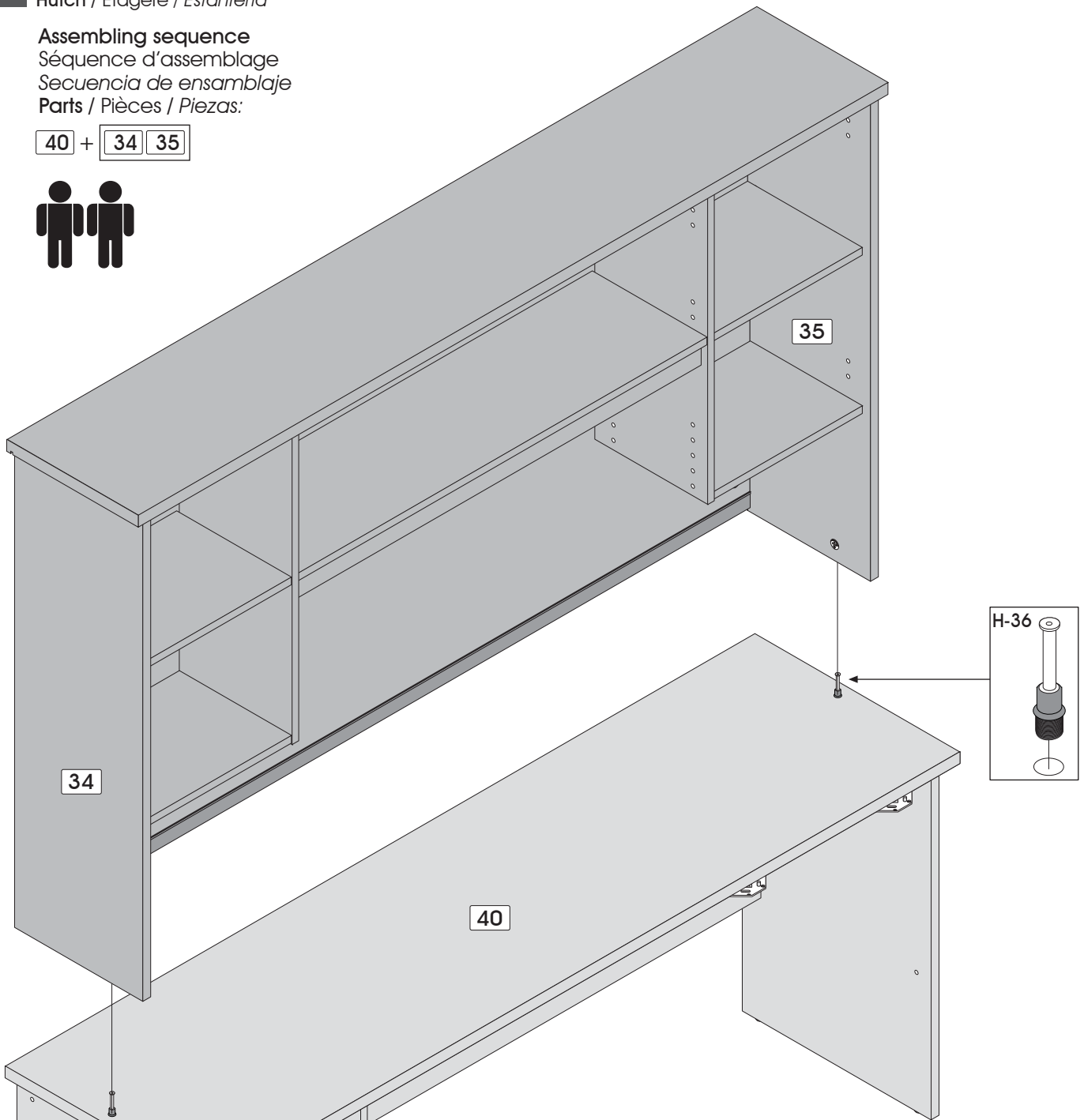

important / importante

A

↑
insert
insérez
insertar

B

tighten
serrez
apretar

9

Code / Código
 Qty / Qté / Cant. x 2

10 HARDWARE INSTALLATION / INSTALLATION DES QUINCAILLERIES / INSTALACIÓN DE LAS QUINCALLAS

Doors & Drawers / Portes et tiroirs / Puertas y cajones

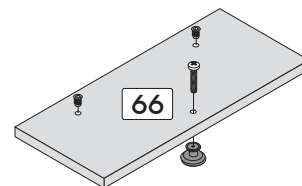
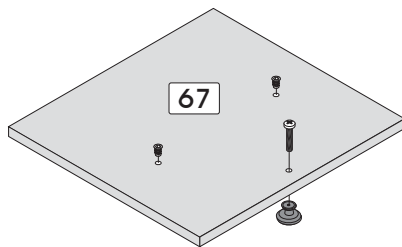
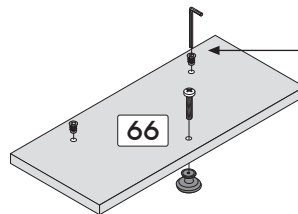
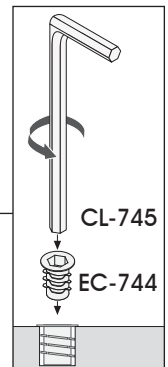
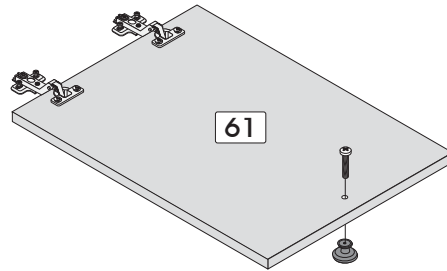
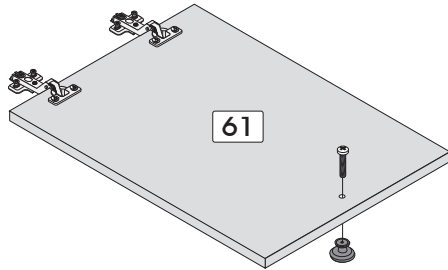
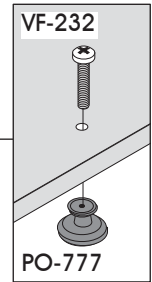
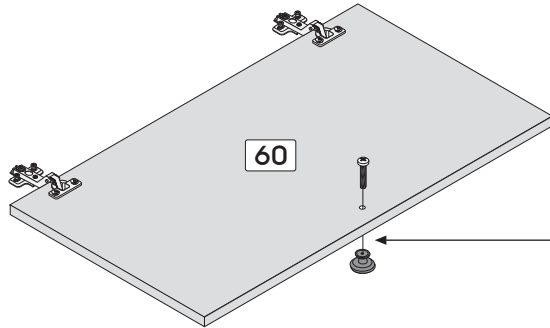
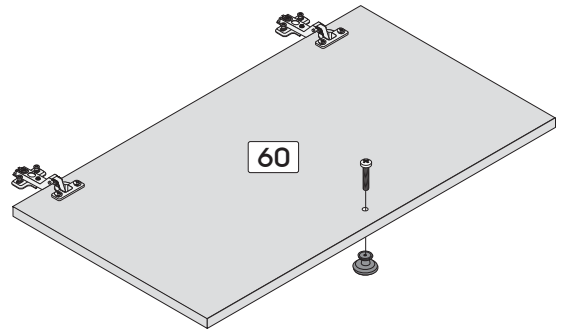
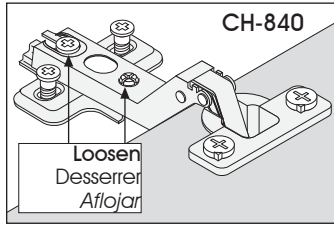

10

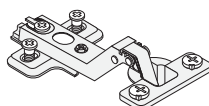

Code / Código
Qty / Qté / Cant.

CH-840
x 8

PO-777
x 7

CL-745
x 1

EC-744
x 6

VF-232
7/16" (22 mm)
x 7

Drawers & Keyboard Shelf / Tiroirs et tablette à clavier / Cajónes y estante para teclado

important / importante

Drive the screw all the way in to install CO-843.
 Vissez à fond avant d'installer la CO-843.
 Atornille a fondo antes de instalar el CO-843.

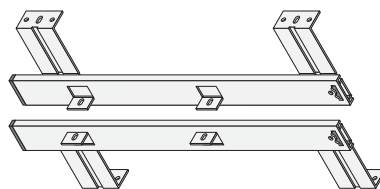
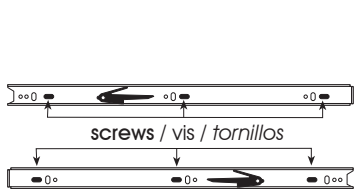
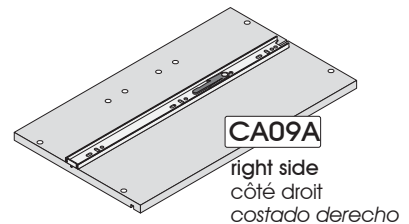
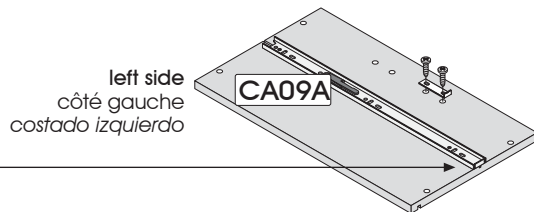
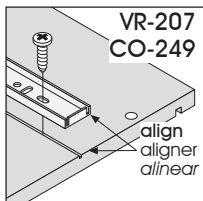
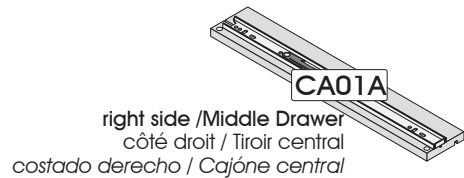
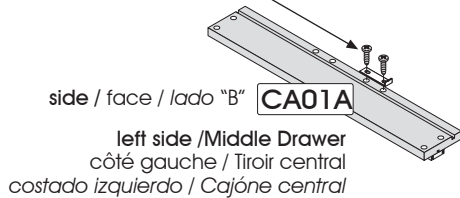
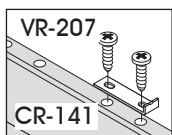
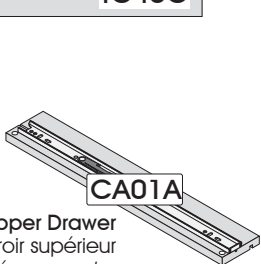
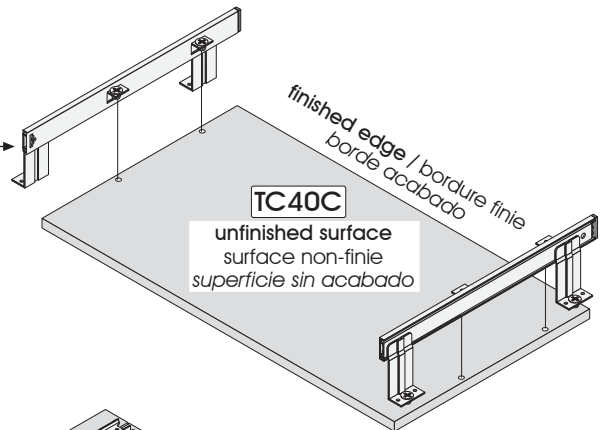
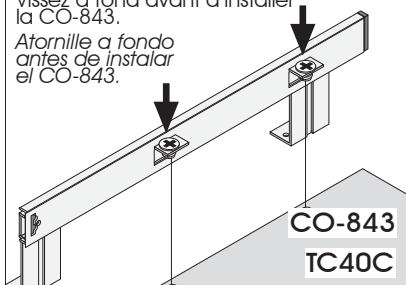

Code / Código
 Qty / Qté / Cant.

CO-249
 x 3

CO-843
 x 1

CR-141
 x 2

VR-207
 x 22

12 ASSEMBLY / ASSEMBLAGE / ENSAMBLAJE

MIDDLE Drawer / Tiroir CENTRAL / Cajón CENTRAL

Assembling sequence
 Séquence d'assemblage
 Secuencia de ensamblaje
 Parts / Pièces / Piezas:

CA05A CA01A CA01A + bottom / fond / fondo + CA05A 66

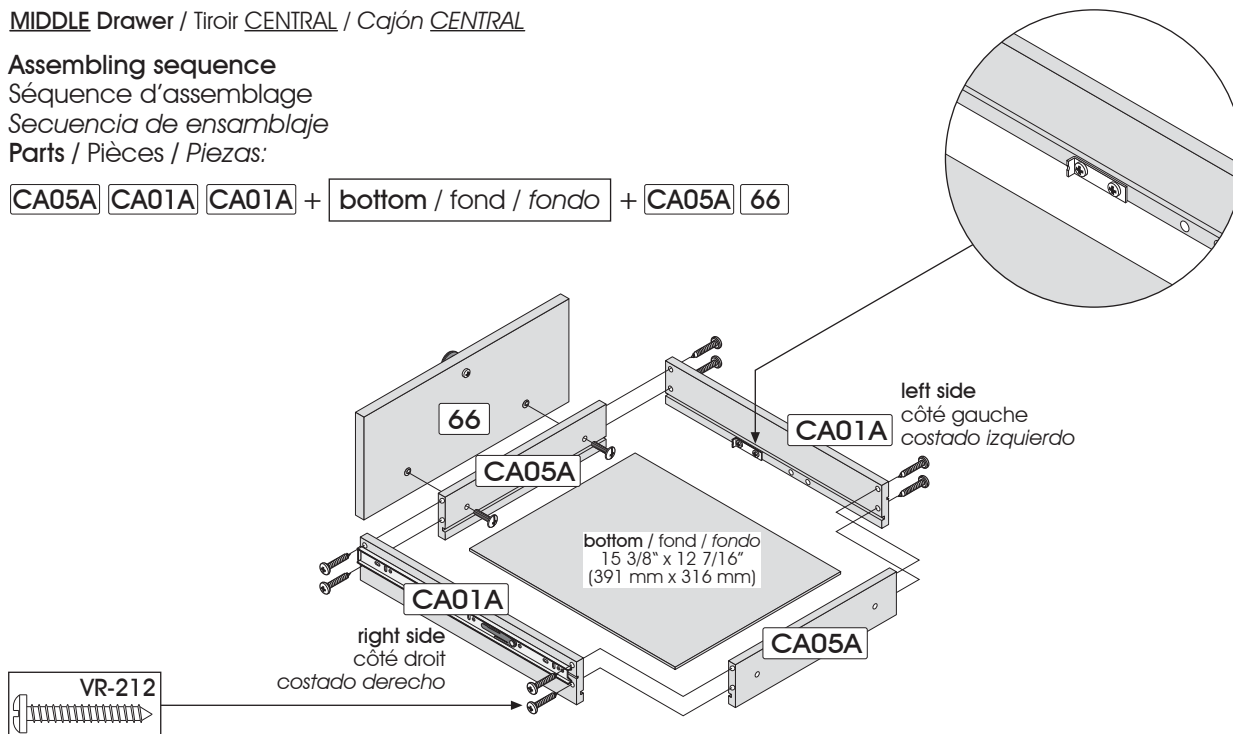

UPPER Drawer / Tiroir SUPÉRIEUR / Cajón SUPERIOR

Assembling sequence
 Séquence d'assemblage
 Secuencia de ensamblaje
 Parts / Pièces / Piezas:

CA05A CA01A CA01A +
 bottom / fond / fondo + CA05A 66

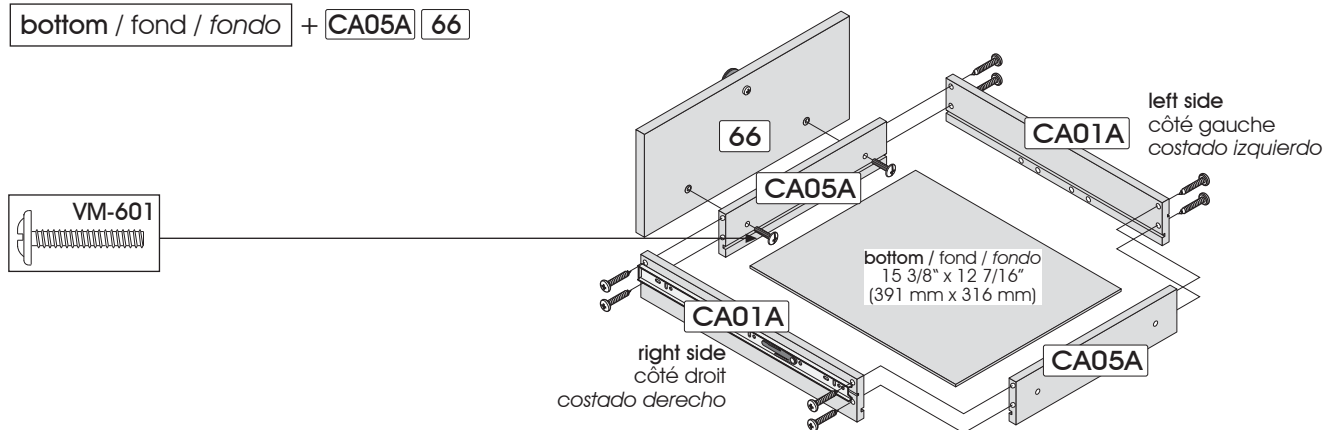

12



Code / Código VM-601

Qty / Qté / Cant. x 4



Code / Código VR-212

Qty / Qté / Cant. x 16

Assembling sequence
 Séquence d'assemblage
 Secuencia de ensamblaje
 Parts / Pièces / Piezas:

CA13A EX-681 + CA09A EX-702 + CA09A EX-702 +
 bottom / fond / fondo + CA13A EX-681 + 67

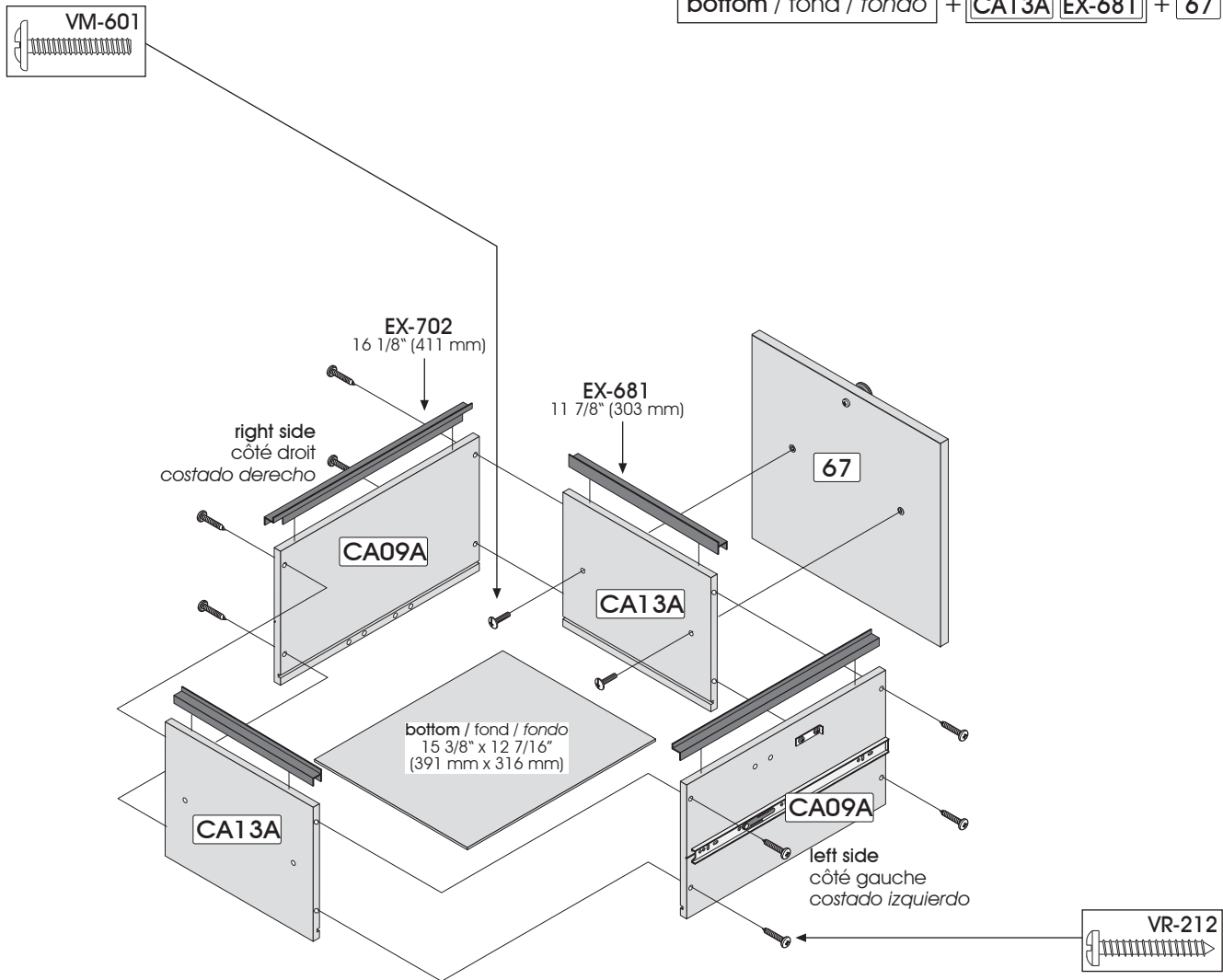

Code / Código	EX-681	EX-702	VR-212	VM-601
Qty / Qté / Cant.	x 2	x 2	x 8	x 2

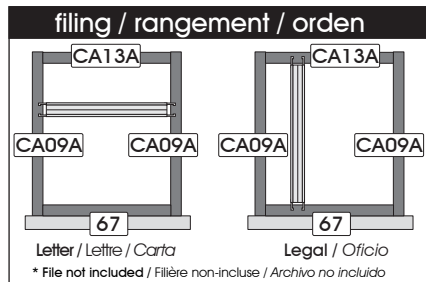

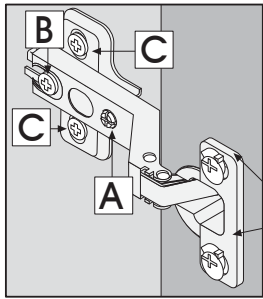

Use screw A for horizontal adjustment, screw B for depth adjustment and screws C for vertical adjustment.

Utilisez la vis A pour l'ajustement horizontal, les vis B pour l'ajustement en profondeur et les vis C pour l'ajustement vertical.

Utilice el tornillo A para realizar el ajuste horizontal, los tornillos B para el ajuste de profundidad y los tornillos C para el ajuste vertical.

To remove hinges (CH-840), start by loosening these two screws to free the locking system.

Pour enlever les pentures (CH-840), desserrez ces deux vis d'abord pour libérer le système de verrouillage.

Para retirar las bisagras (CH-840), afloje primero estos dos tornillos para liberar el sistema de fijación.

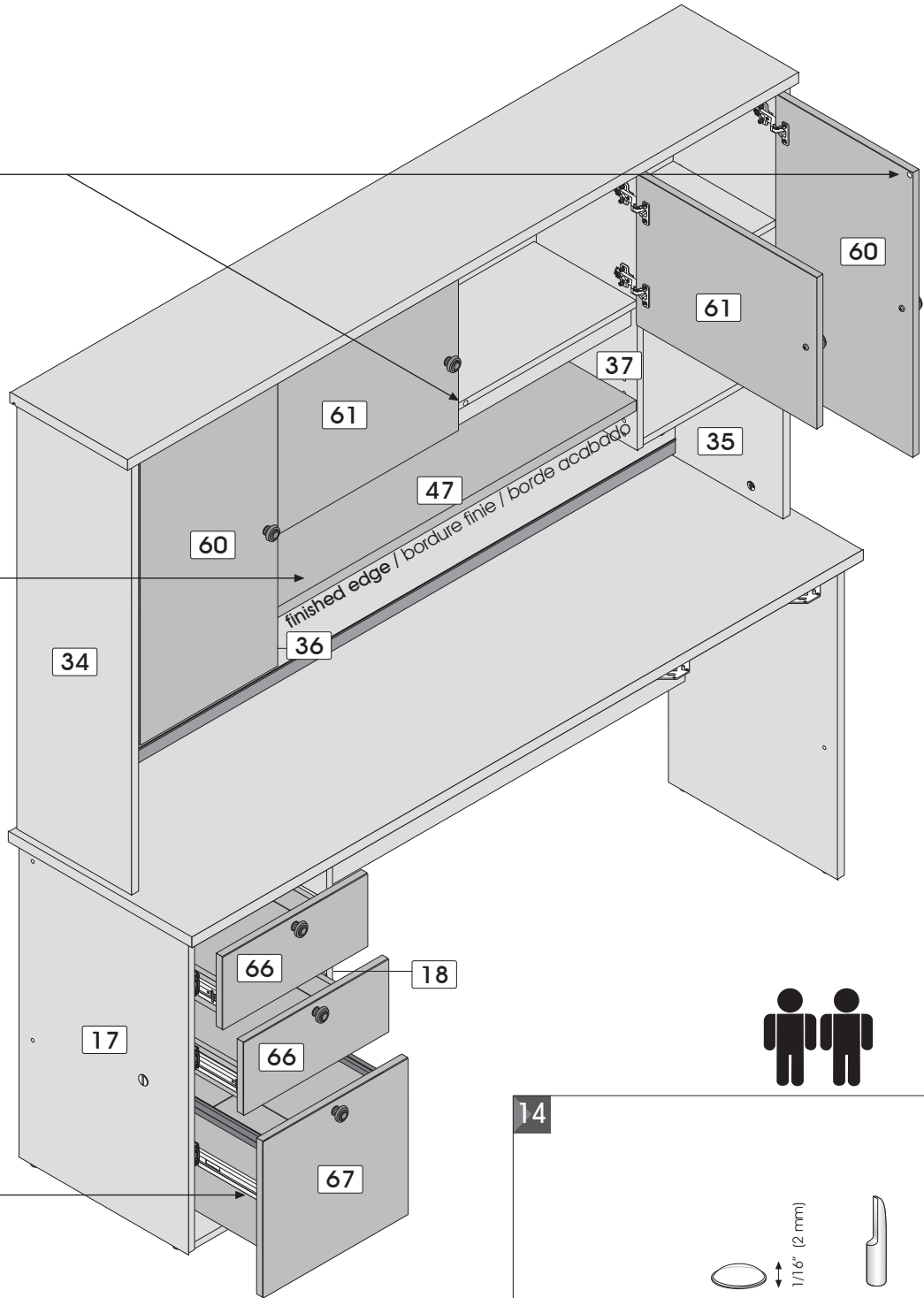
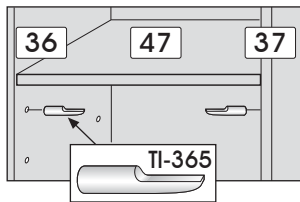

important
importante

Ball bearings must be on front part of slider when installing drawers.
Les roulements à billes doivent être sur la partie avant du coulisseau lors de l'installation des tiroirs.
Los cojinetes de bolas deben ubicarse sobre la parte delantera de guía en el momento de instalar los cajones.



14		
Code / Código	AM-182	TI-365
Qty / Qté / Cant.	x 4	x 4

Important/Importante

3 possibilities for left assembly / 3 possibilités pour l'assemblage gauche / 3 posibilidades para el ensamblaje izquierdo

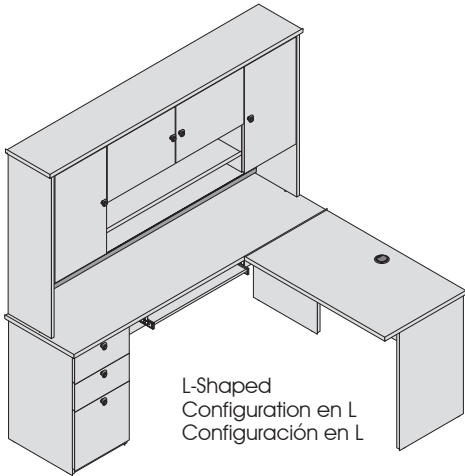

For L-Shaped configuration, please refer to page 21
 Pour la configuration en L, référez-vous à la page 21
 Para la configuration en L, vea a la página 21

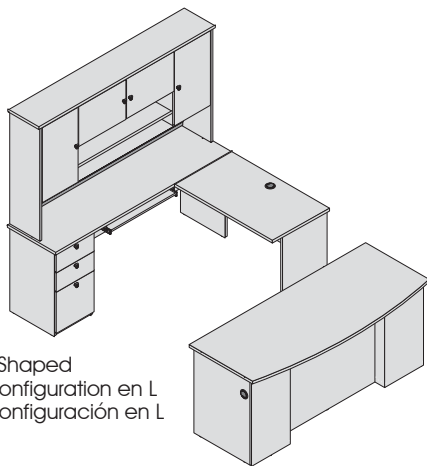

For L-Shaped configuration, please refer to the page 21
 and to the instructions manual.

Pour la configuration en L, référez-vous à la page 21
 et au feuillet d'instructions.

Para la configuration en L,
 vea página 21 y el manual instrucciones.

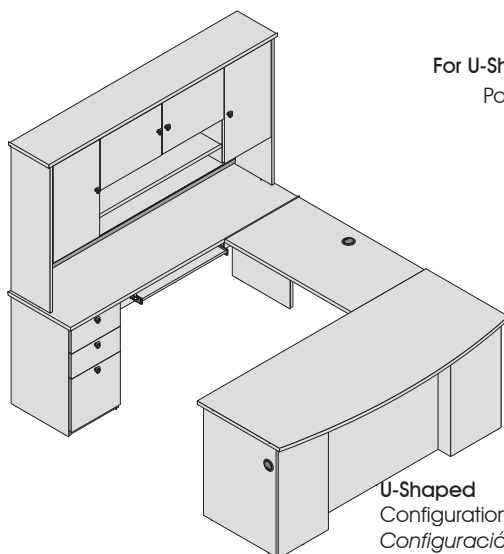

For U-Shaped configuration, please refer to the instructions manual

Pour la configuration en U, référez-vous au feuillet d'instructions

Para la configuration en U, vea el manual instrucciones

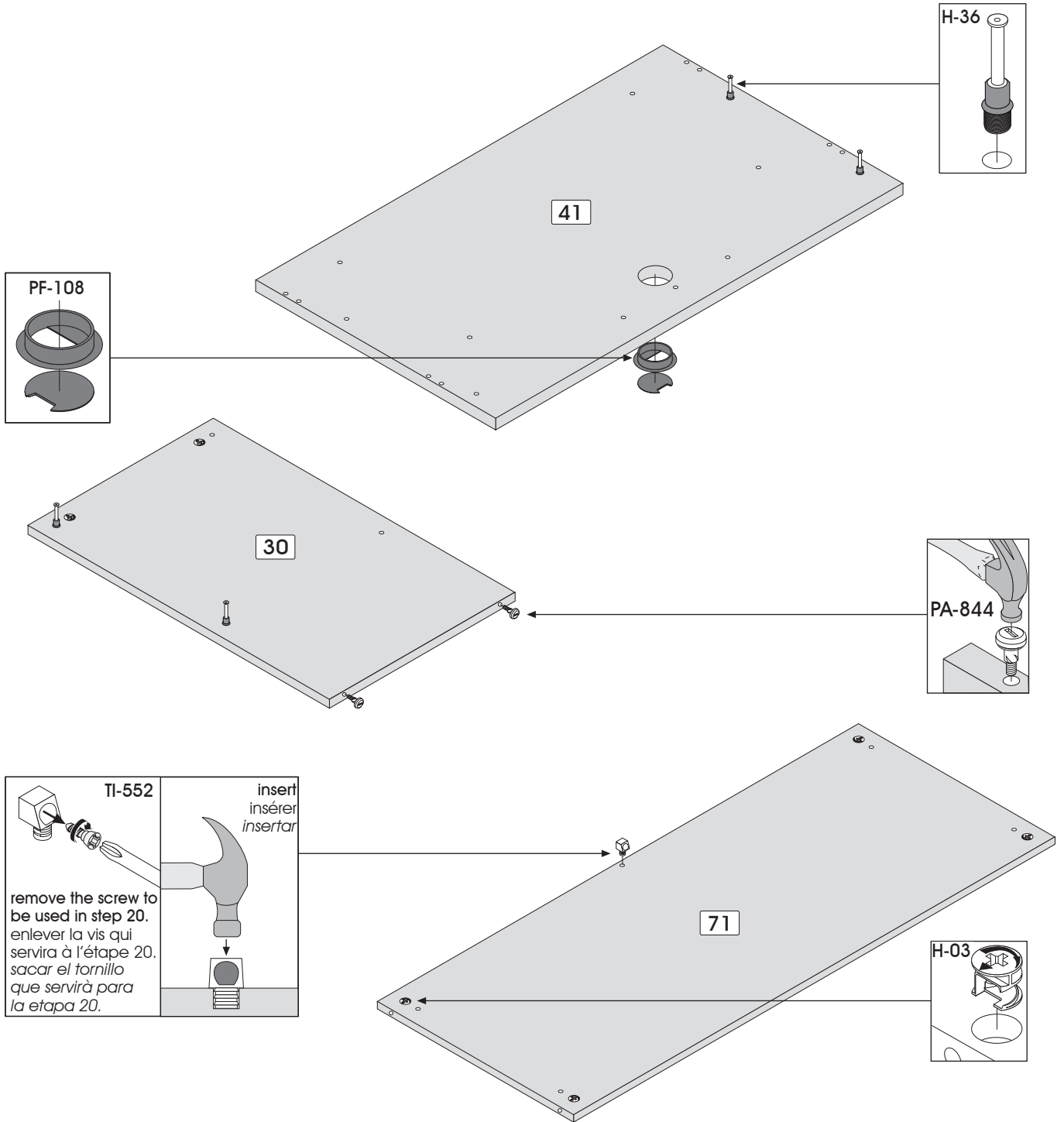

TI-552

remove the screw to be used in step 20.
 enlever la vis qui servira à l'étape 20.
 sacar el tornillo que servirá para la etapa 20.

insert
 insérer
 insertar

Code / Código	H-03	H-36	PA-844	PF-108	TI-552
Qty / Qté / Cant.	x 6	x 4	x 2	x 1	x 1

Assemble upside down
 Assemblez en position renversée
 Realice el ensamblaje en posición invertida

Assembling sequence
 Séquence d'assemblage
 Secuencia de ensamblaje
 Parts / Pièces / Piezas:

41 30 71

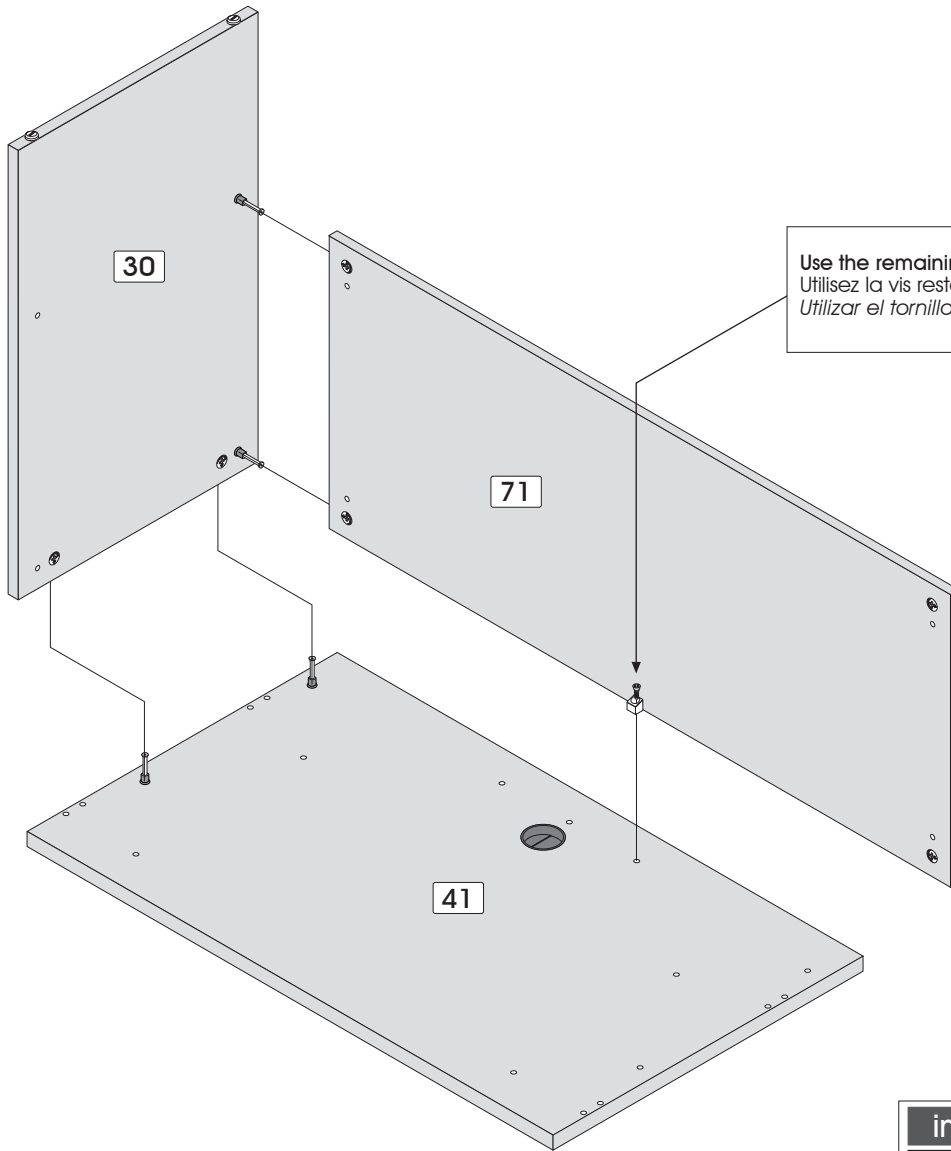

Use the remaining screw from step 16.
 Utilisez la vis restante de l'étape 16.
 Utilizar el tornillo restante de la etapa 16.

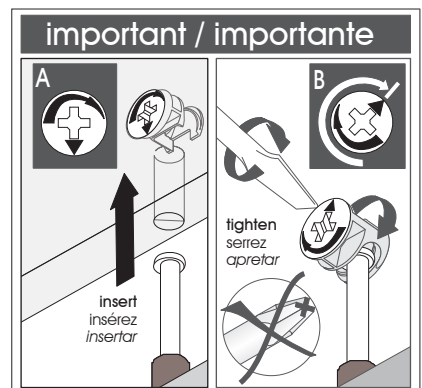
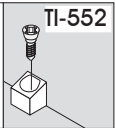

Assembling sequence
 Séquence d'assemblage
 Secuencia de ensamblaje
 Parts / Pièces / Piezas:

30 40 + EQ-143 + 41 71

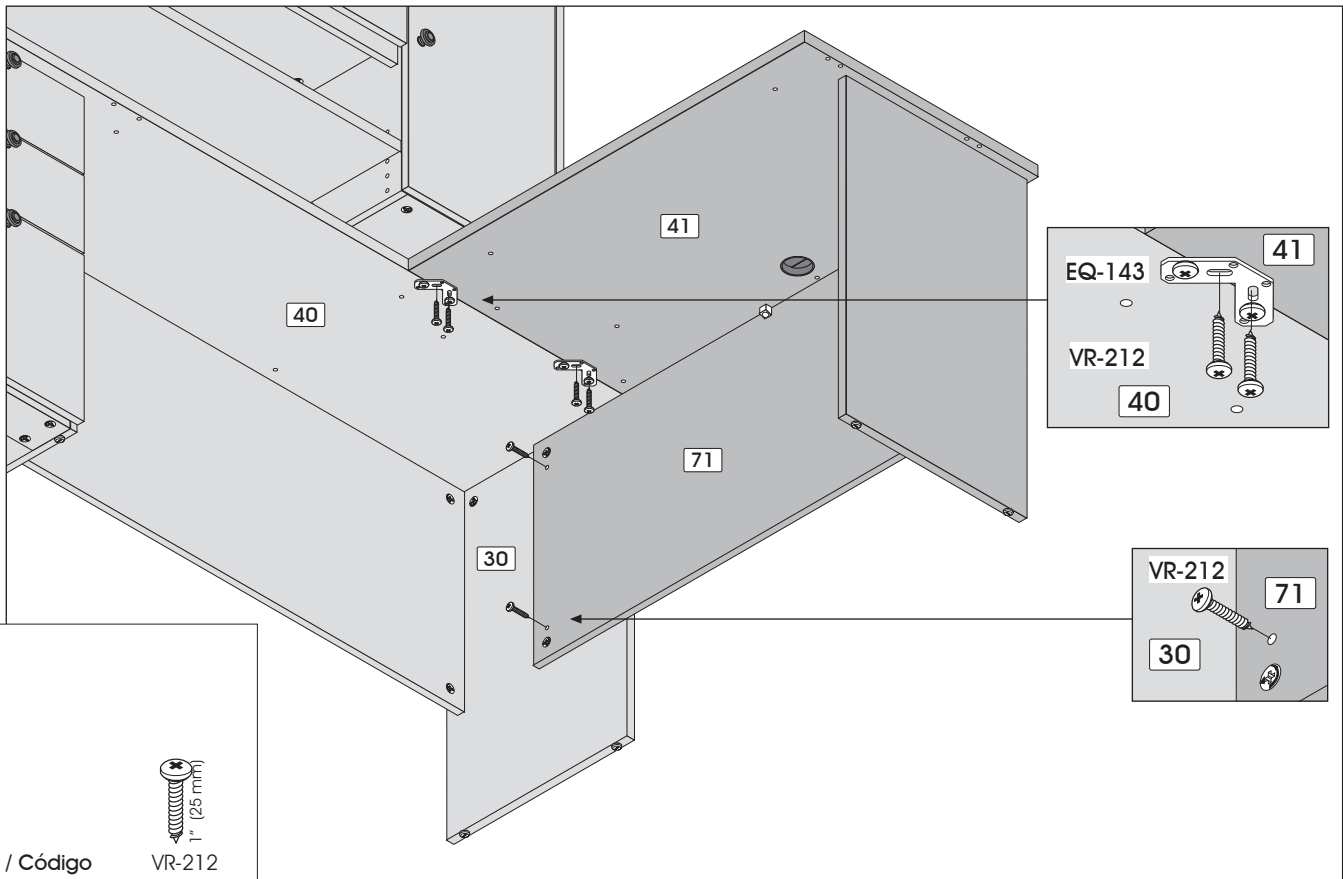
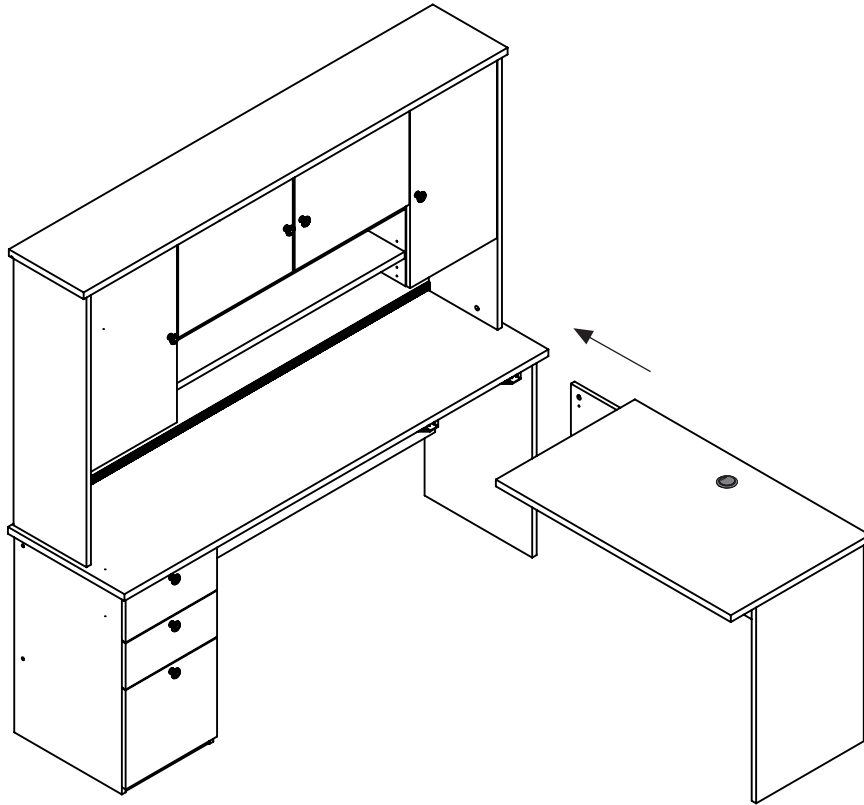

Code / Código VR-212
 Qty / Qté / Cant. x 6

19 INSTALLATION / INSTALLATION / INSTALACIÓN

Keyboard Shelf / Tablette à clavier / Estante para teclado

important / importante

2 possibilities / 2 possibilités / 2 posibilidades

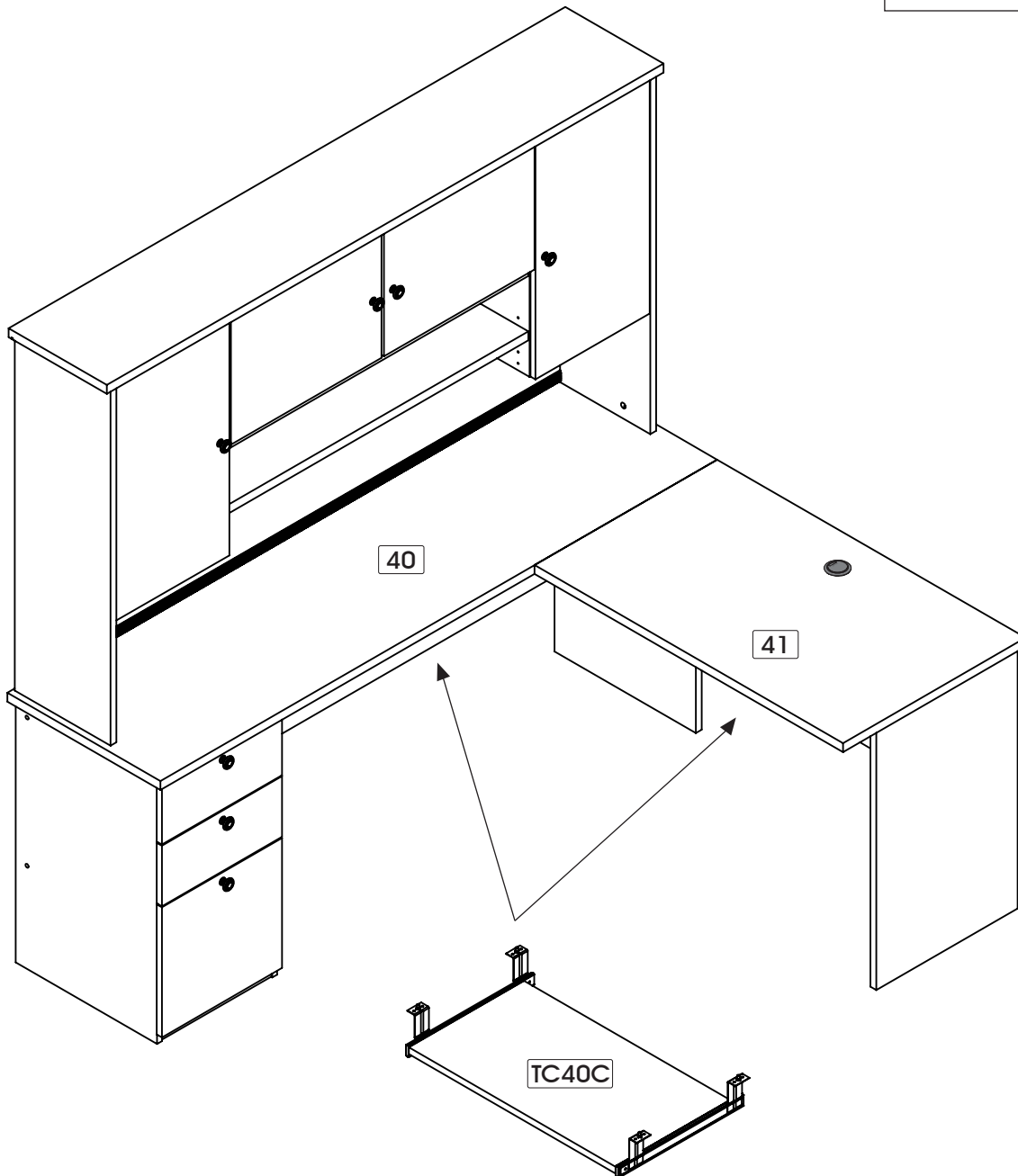
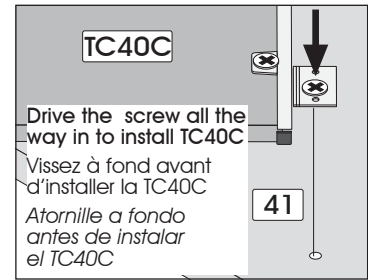

Important/Importante

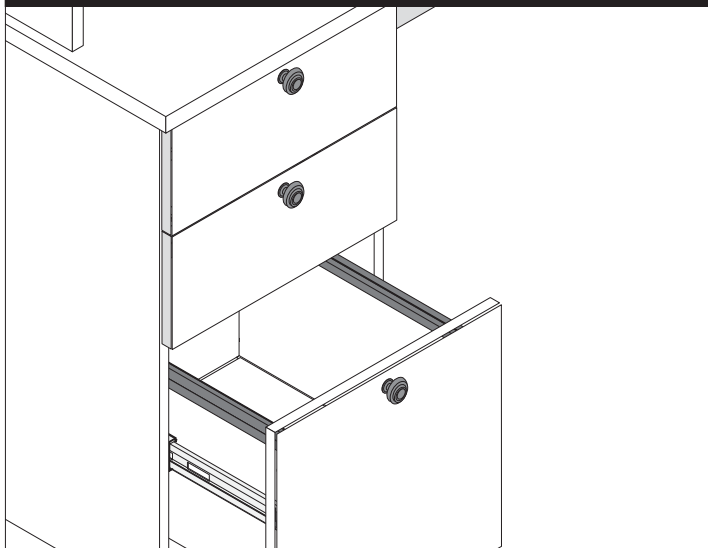

For future reference and to better serve you, please apply the self-adhesive sticker in an accessible space such as inside a drawer.

Pour mieux vous servir en cas de besoin, veuillez apposer l'autocollant dans un endroit facilement accessible tel que l'intérieur d'un tiroir.

Para futura referencia y mejor servicio por favor pegue la etiqueta en un lugar accesible, por ejemplo al interior de un cajón.

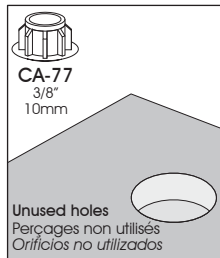
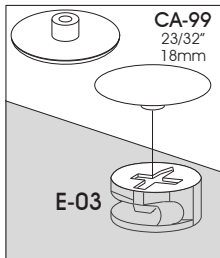

When you have completed the assembly of your new furniture, install plastic caps.

Lorsque vous avez complété l'assemblage de votre meuble, installez les capuchons de plastique.

Una vez que haya ensamblado el mueble, coloque los capuchones de plástico.

PRODUCT CARE / ENTRETIEN DU PRODUIT / MANTENIMIENTO DEL PRODUCTO

Avoid placing the furniture in the sunlight or near a source of heat. Use a soft dry cloth for dusting. To clean heavy dirt, use a cloth dipped in a solution of mild detergent and water. Avoid leaving wet objects on the surface or using commercial chemical cleaning products.

Évitez d'exposer le meuble au soleil ou près de toute source de chaleur. Pour le nettoyage, utilisez un chiffon doux et sec. Pour la grosse saleté, utilisez un chiffon humidifié avec un peu de détergent dilué dans l'eau. Évitez de laisser des objets mouillés sur la surface de votre meuble ou d'utiliser des nettoyeurs chimiques.

Evite exponer el mueble al sol o las fuentes de calor. Para limpiarlo, utilice un paño suave y seco. Para limpiar las manchas rebeldes, utilice un trapo húmedo con un poco de detergente diluido en agua. No deje objetos mojados encima del mueble ni utilice limpiadores que contengan productos químicos.

CONGRATULATIONS! YOU ARE NOW THE OWNER OF A QUALITY PRODUCT
FÉLICITATIONS! VOUS AVEZ MAINTENANT EN VOTRE POSSESSION UN PRODUIT DE QUALITÉ
FELICITACIONES! AHORA ES USTED DUEÑO DE UN PRODUCTO DE CALIDAD.



For more information or to discover our new products

Pour toute information ou pour découvrir nos nouveaux produits

Para más información o descubrir nuestros nuevos productos



FOR LONG TIME
POUR LONGTEMPS
POR MUCHO TIEMPO