

UPHOLSTERY PLATFORM BED

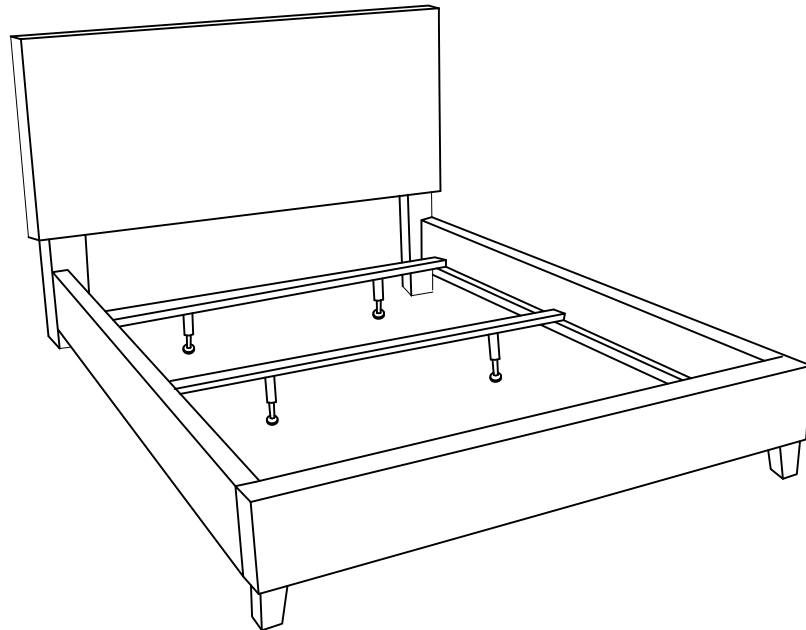

CAUTION

PLEASE DO NOT RETURN THIS ITEM TO STORE WHERE IT WAS PURCHASED

We appreciate your selection of our product. You can have confidence in this product that incorporates quality components.

Upholstered furniture care instructions

- Vacuum your upholstered furniture regularly. Small dust particles are very abrasive and can wear furniture prematurely.
- Blot spills immediately to prevent staining. If necessary, gently wipe away the spill using a soft, clean cloth dampened with lukewarm water. Allow to dry and brush lightly.
- Never use harsh chemicals or solvents on your upholstered furniture as this may damage the fabric.
- Never use water to clean your furniture as it may cause damage to the finish.
- If you choose to use a professional product, pretest the fabric in an inconspicuous area for any signs of discoloration or shrinking.
- Marks and stains from pens, crayons and ink markers are difficult to remove. In the event that your furniture becomes permanently stained, we recommend that you consult a professional.





Quality statement

It is appreciated your selection of this product, we know you had many other choices.

Please pay attention that proper care and cleaning at home will extend the life of your purchase. Following these important and helpful tips will enhance your furniture as it ages.

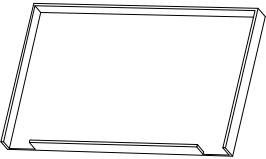
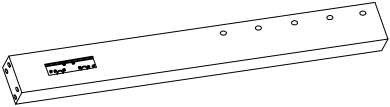
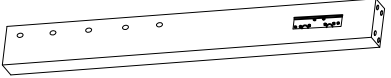
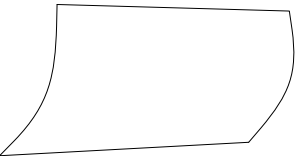
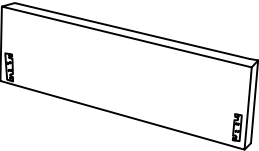

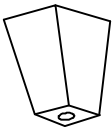

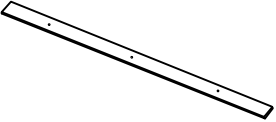
PART LIST

PLEASE ALWAYS CHECK EVERY PART BEFORE YOUR ASSEMBLY

A	1 PC	L	1 PC	R	1 PC
Headboard Panel		Left Leg		Right Leg	
					
D	1 PC	E	1 PC	F	2 PCS
Back Cover		Footboard		Side Rail(in other box)	
					
G	2 PCS	H	6 PCS	I	3 PCS
Wood Feet		Support Feet		Wooden Slat(in other box)	
					

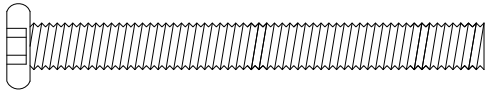
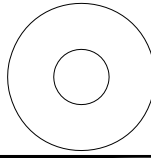
Hardware List

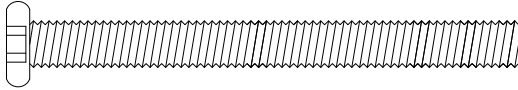
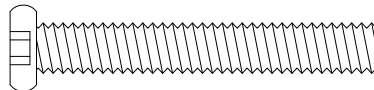
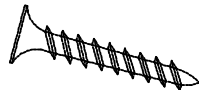
PLEASE ALWAYS CHECK EVERY PART BEFORE YOUR ASSEMBLY
NOTE: HARDWARE NOT SHOWN TO ACTUAL SIZE IN THE FIGURES BELOW

①	4 PCS	②	12 PCS	③	12 PCS
Ø1/4" x 65mmL Allen Bolts		Flat Washers		Spring Washers	
					
④	2 PCS	⑤	6 PCS	⑥	12 PCS
Ø1/4" x 75mmL Allen Bolts		Ø1/4" x 50mmL Allen Bolts		Wood Screw	
					
⑦	1 PC				
Allen Wrench					
					

This Page lists all the contents included in the box. Please take the time to identify the hardware as well as the individual components to this product. As you unpack and prepare for assembly, place the contents on a carpeted or padded area to protect them from damage.

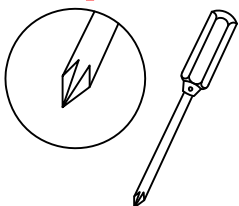

Phillips head screwdriver(not include)are necessary for assembly
Use the phillips head screwdriver to tighten the wood screw

IMPORTANT!!

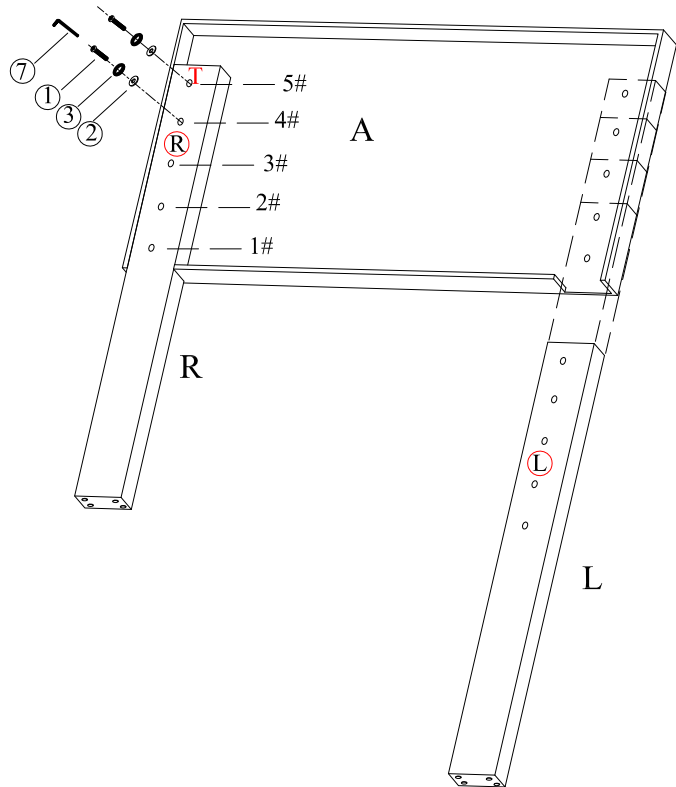

**For making the entire unit assemble straightly, do not roll screws too tight when first secure the screw 80% is fine, after finish all screws, secure them completely and tightly.

**Please also check your thickness of mattress and box spring before your assemble.

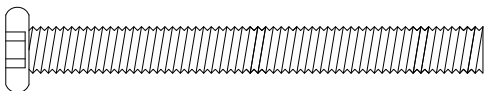
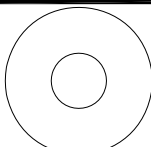

IMPORTANT!
Please check your box spring
and / or mattress thickness
before your assembly.

Box Spring + Mattress	Adjustable Headboard Height
Under 14"	T match 5#
14"~18"	T match 4#
18"~22"	T match 3#
22"~26"	T match 2#
26"~UP	T match 1#

①	4 PCS	②	4 PCS
Ø1/4" x 65 mmL Allen Bolts		Flat Washers	
			
③	4 PCS	⑦	1 PC
Spring Washers		Allen Wrench	
			



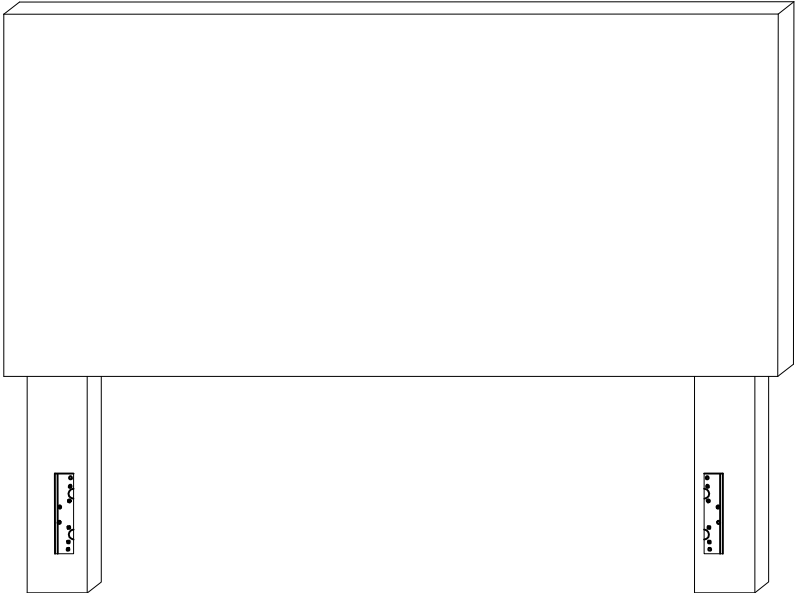
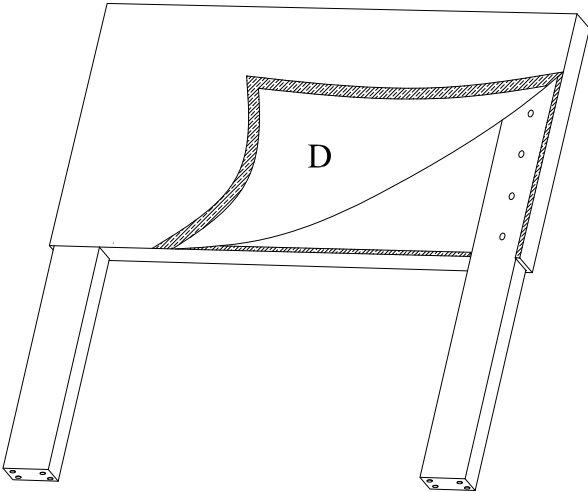

Cover the fabric lining behind the headboard.

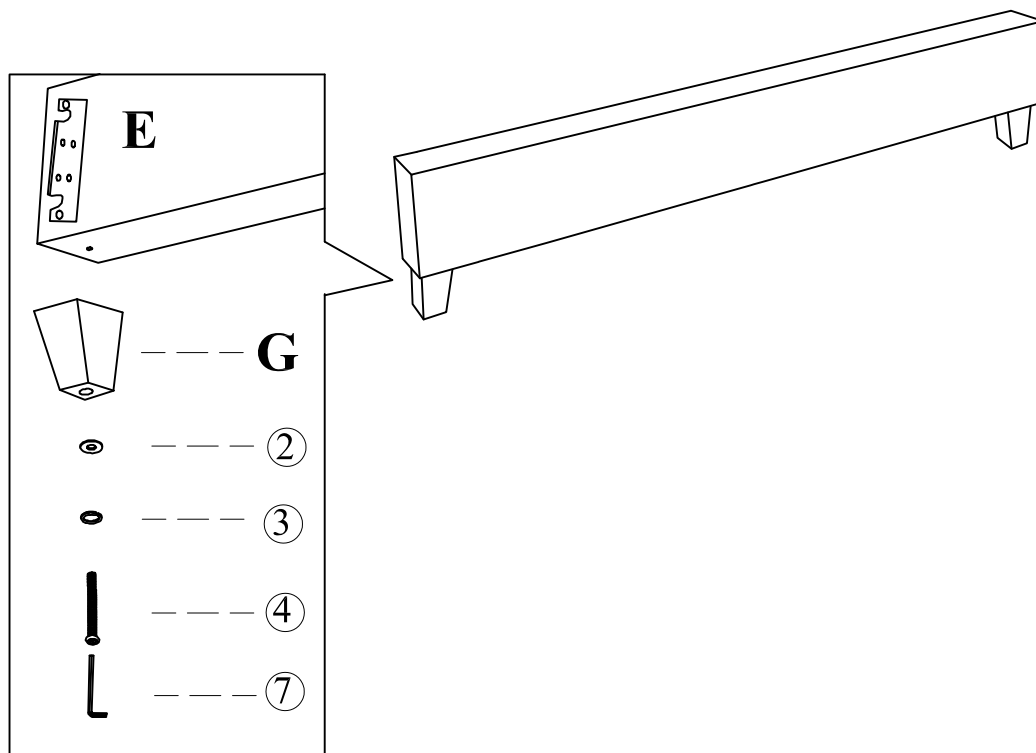

Stand the unit upright, adjust the legs on one level, then tighten all bolts.

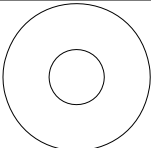
Step 1: Fasten the Footboard(E) & Wood Feet(G)

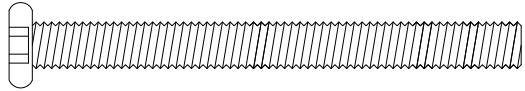

②	2 PCS	③	2 PCS
Flat Washers		Spring Washers	
			
④	2 PCS	⑦	1 PC
Ø1/4" x 75 mmL Allen Bolts		Allen Wrench	
			

Step 2:

Attached Side Rail(F) to the Headboard and Footboard(E).

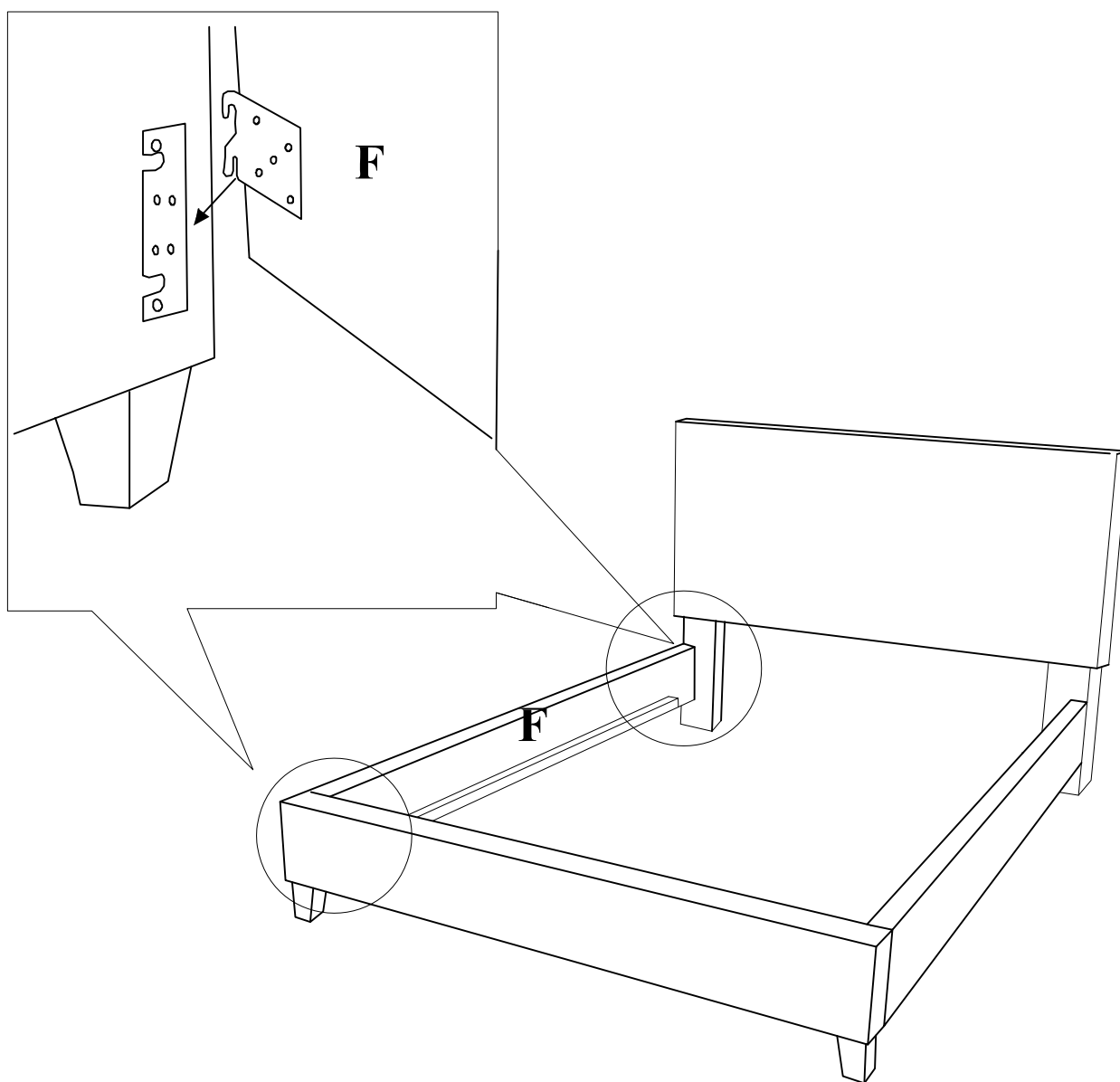

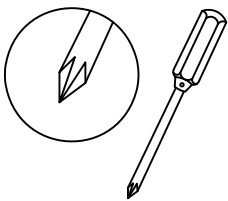
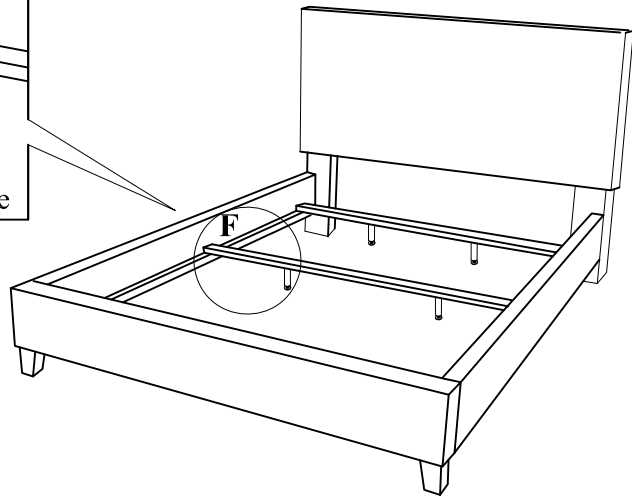
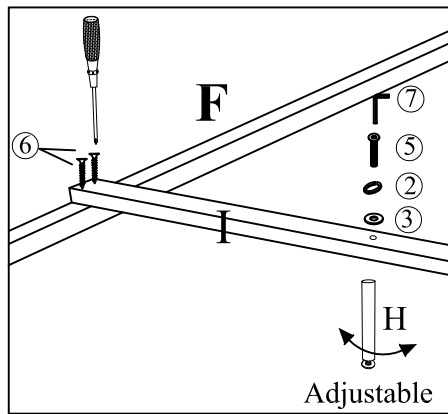

For making the entire unit assemble straightly, do not roll screws too tight when first secure the screw 80% is fine, after finish all screws, secure them completely and tightly.

Step 3: Assembly Wooden Slats(I) and Support Leg (H)

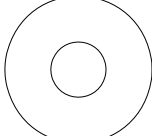

Phillips head screwdriver(not include)
are necessary for assembly
Use the phillips head screwdriver to
tighten the wood screw

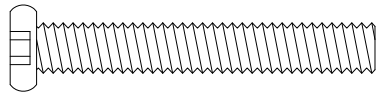
②	6 PCS	③	6 PCS	⑤	6 PCS
Flat Washers		Spring Washers		Ø1/4" x 50 mmL Allen Bolts	
					
⑥	12 PCS	⑦	1 PC		
Wood Screw		Allen Wrench			
