

## Assembly Instructions

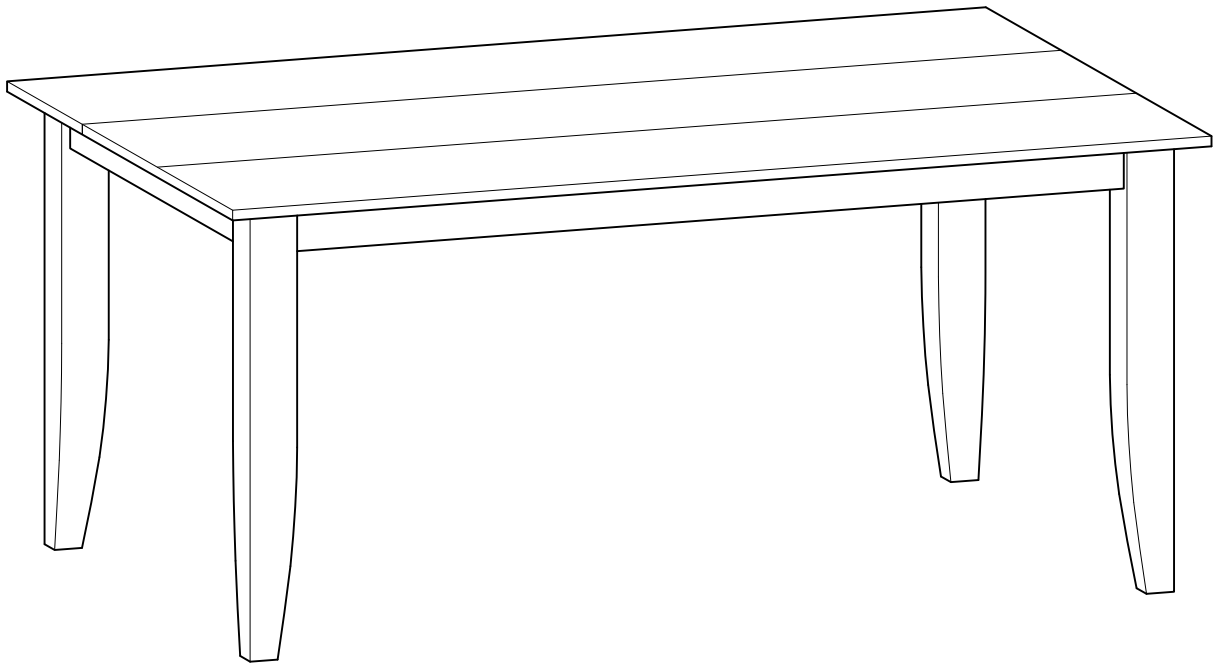

# General Assembly Guidelines

- I. Ensure that all parts and hardware are available before beginning assembly.
- II. Follow each step carefully to ensure the proper assembly of this product.
- III. Two people are recommended for ease in the assembly of this product.
- IV. The three main types of hardware used to assemble this product are: wood dowels, screws and bolts.
- V. The provided glue is to secure wood dowels in place. When first inserting dowels, locate the appropriate hole for the dowel, place a small amount of glue in the hole and insert the dowel. Wipe away excess glue immediately.

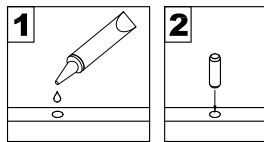

In future assembly steps when dowels are necessary to attach assembly parts together, place a small amount of glue on the end of the dowel before attaching parts together. Wipe away excess glue immediately.

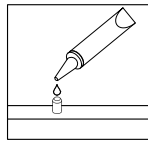

- VI. A Phillips head screwdriver is required for the assembly of this product.

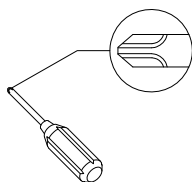

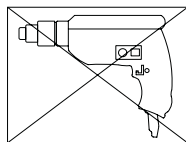

- VII. Power tools should not be used to assemble this product.

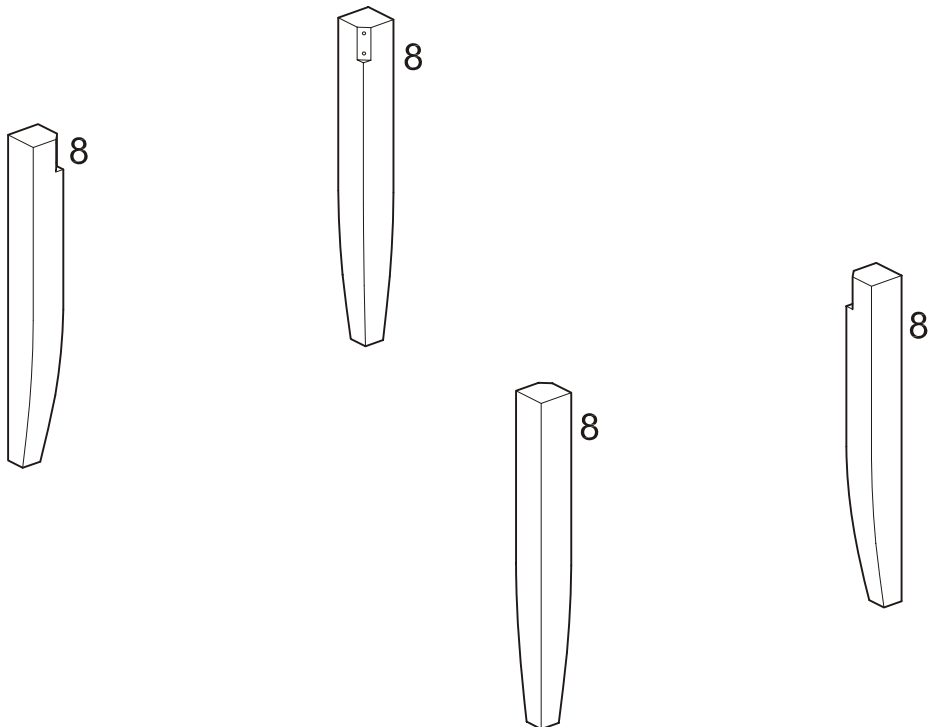
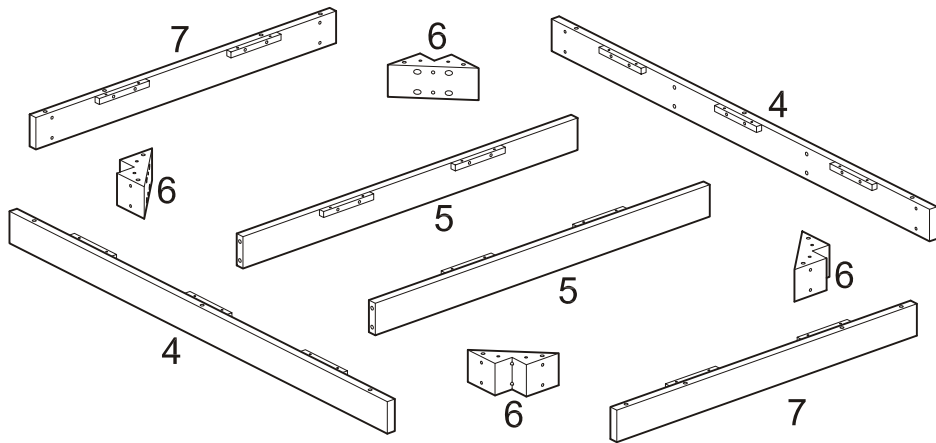
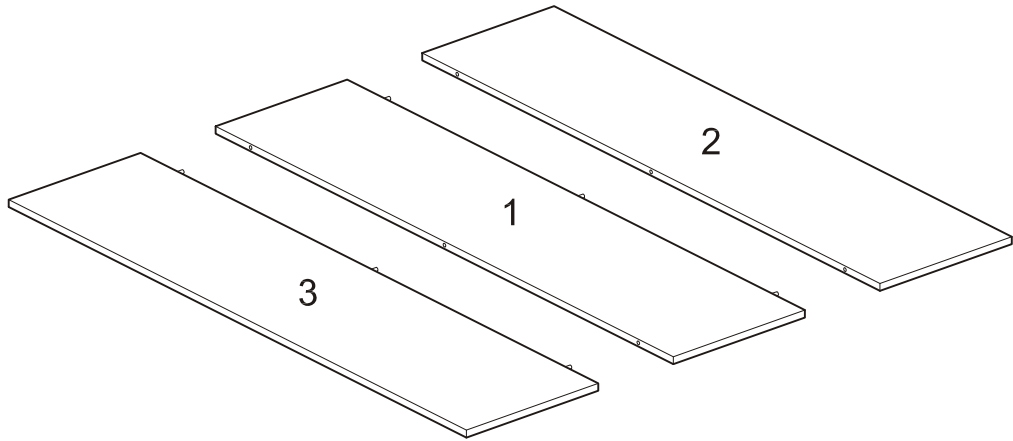

# Parts List

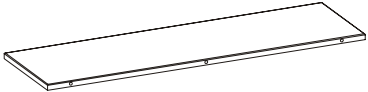
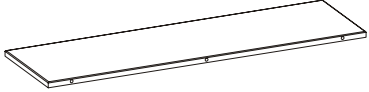
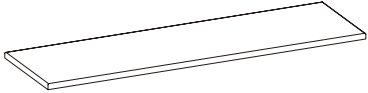
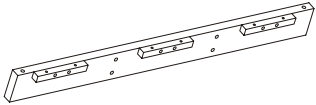
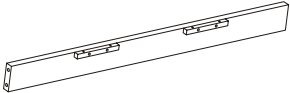

# Component List

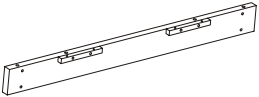
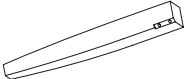
1		Middle panel	1 pc
2		Side panel	1 pc
3		Side panel	1 pc
4		Long apron	2 pcs
5		Inner apron	2 pcs
6		Corner block	4 pcs
7		Short apron	2 pcs
8		Table leg	4 pcs

# Hardware List

A		M5	Wrench	1 pc
B		M10x30(mm)	Wood dowel	30 pcs
C		M4x32(mm)	Screw	52 pcs
D		M8x70(mm)	Large bolt	8 pcs
E		Ø5/16"	Spring washer	8 pcs
F		Ø5/16"	Washer	8 pcs
G			Glue tube	2 pcs

*The hardware quantities listed above are required for proper assembly. Some extra hardware may also have been included.*

# Step 1

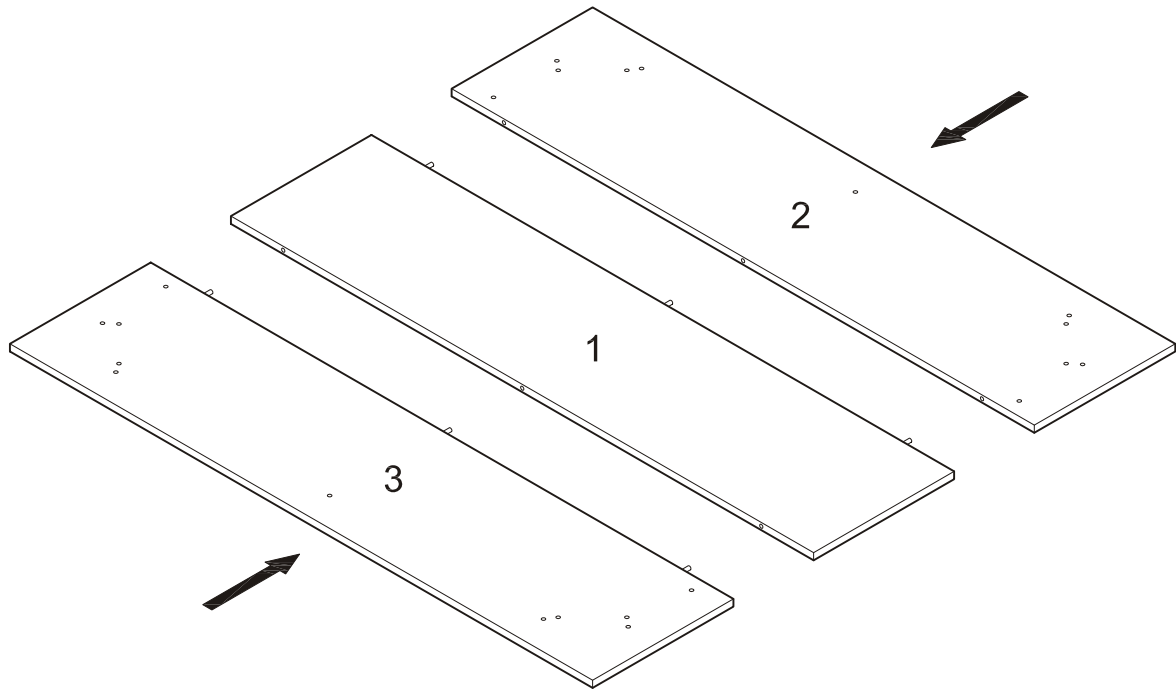

Attach panels (1,2,3) together. *Ensure that panels (1,2,3) connect firmly.*

# Step 2

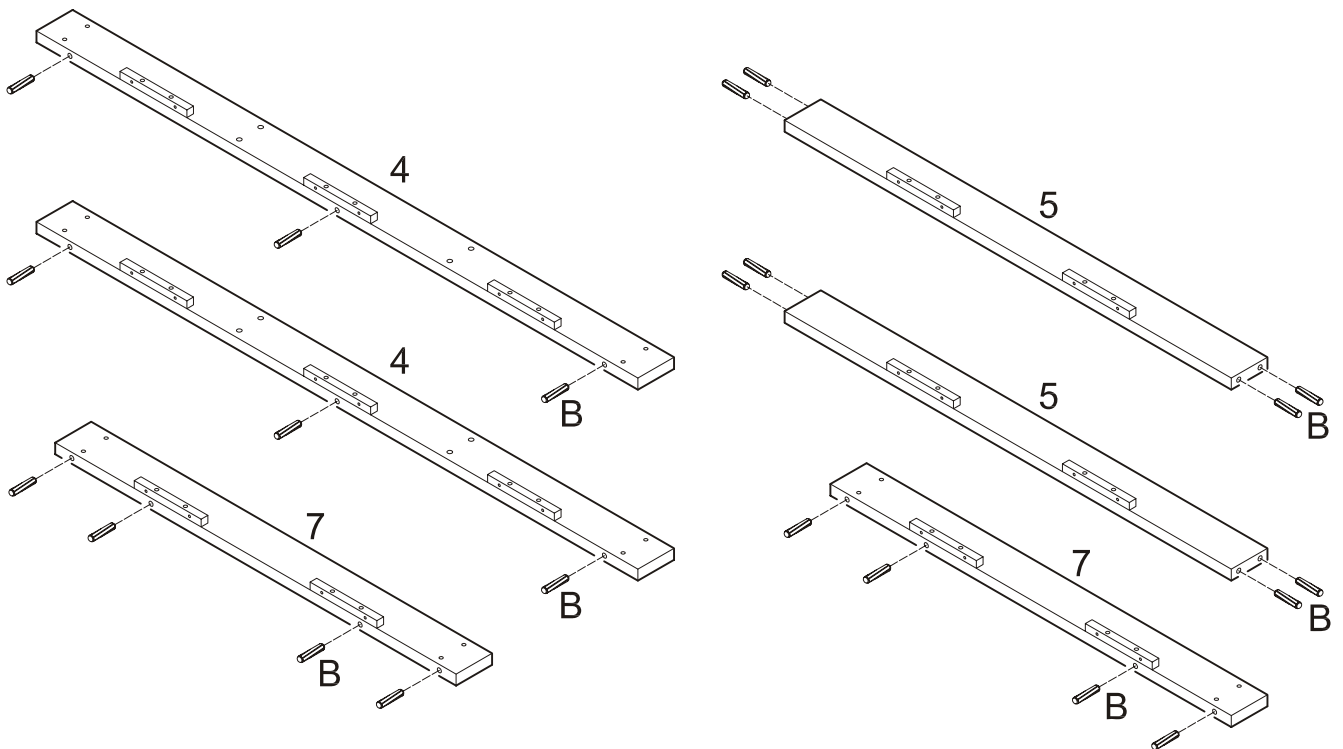

Insert dowels (B) into aprons (4,5,7).

## Step 3

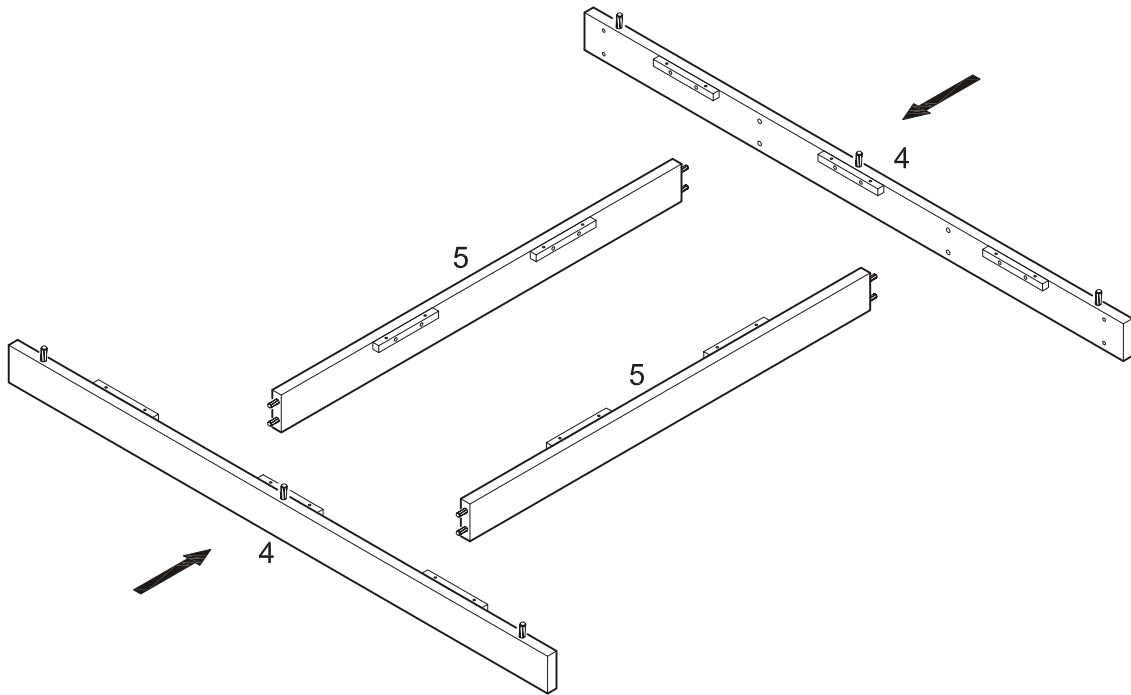

Attach inner aprons (5) to long aprons (4) using dowels as guides.

## Step 4

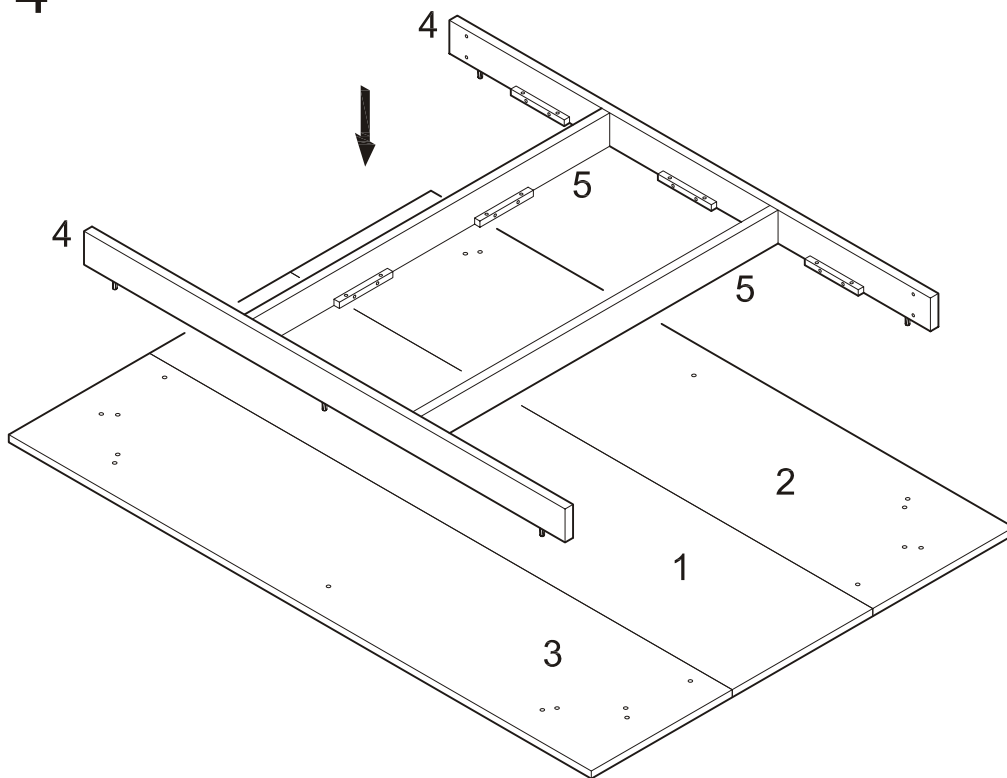

Attach the apron assembly from the previous step to the table top using dowels as guides.

## Step 5

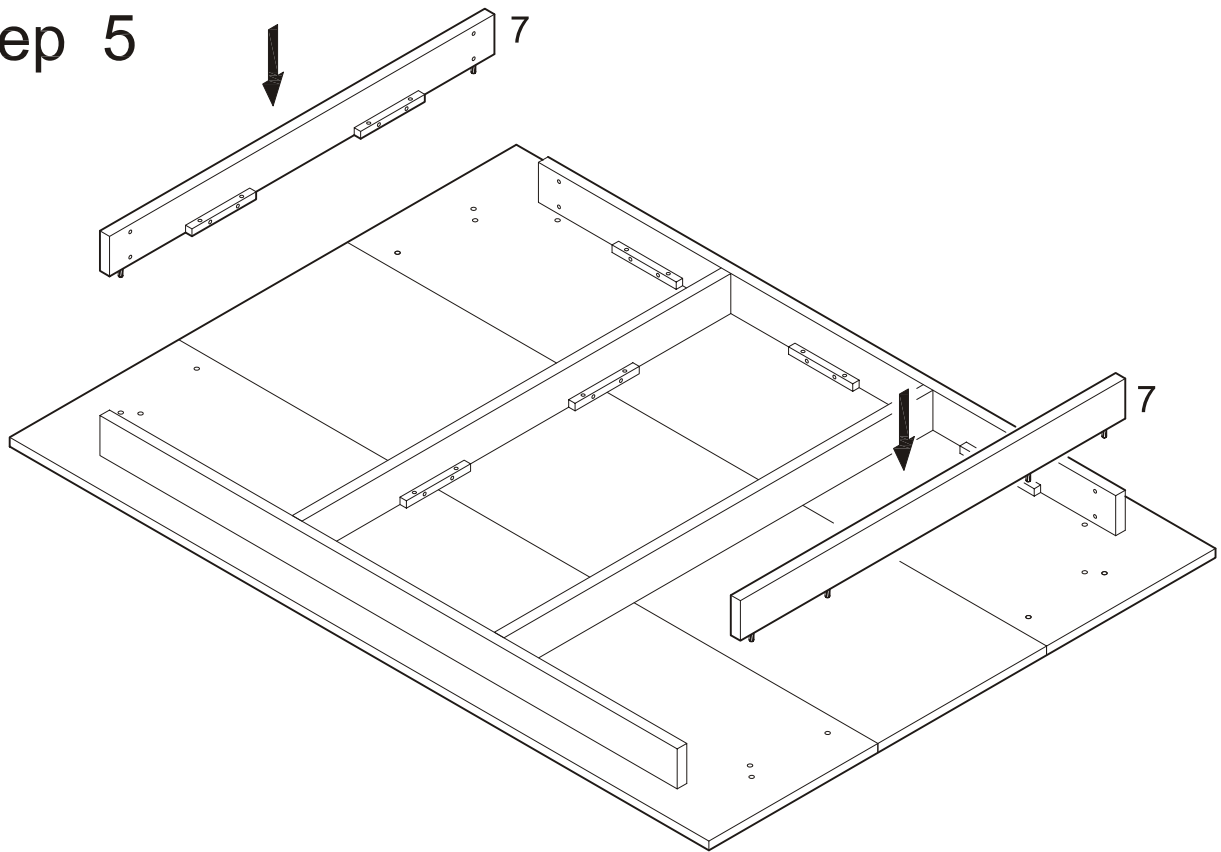

Attach short aprons (7) to the table top using dowels as guides.

## Step 6

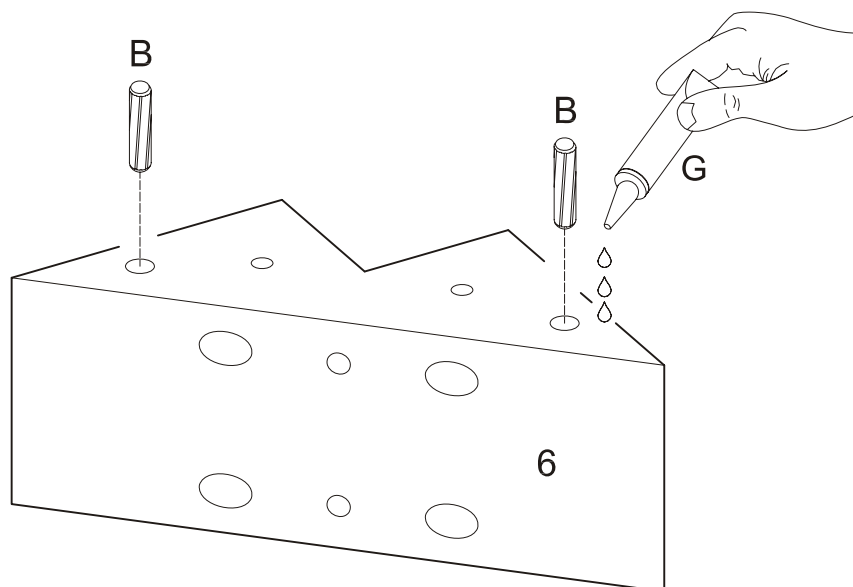

Insert dowels (B) into corner block (6). Apply glue (G) to the surface of corner block (6). Repeat this step for all corner blocks (6).



## Step 7

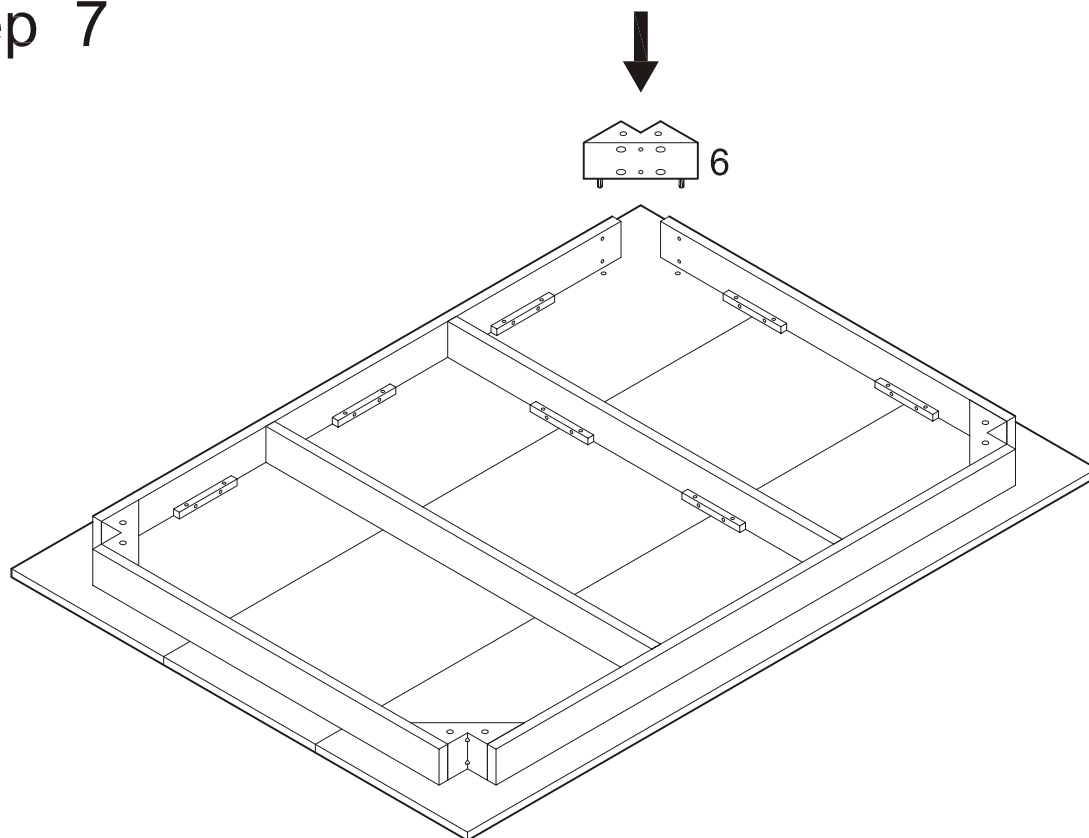

Attach corner blocks (6) to the table top using dowels as guides. *Note that the glued surface of each corner block (6) will rest against the table top.*

## Step 8

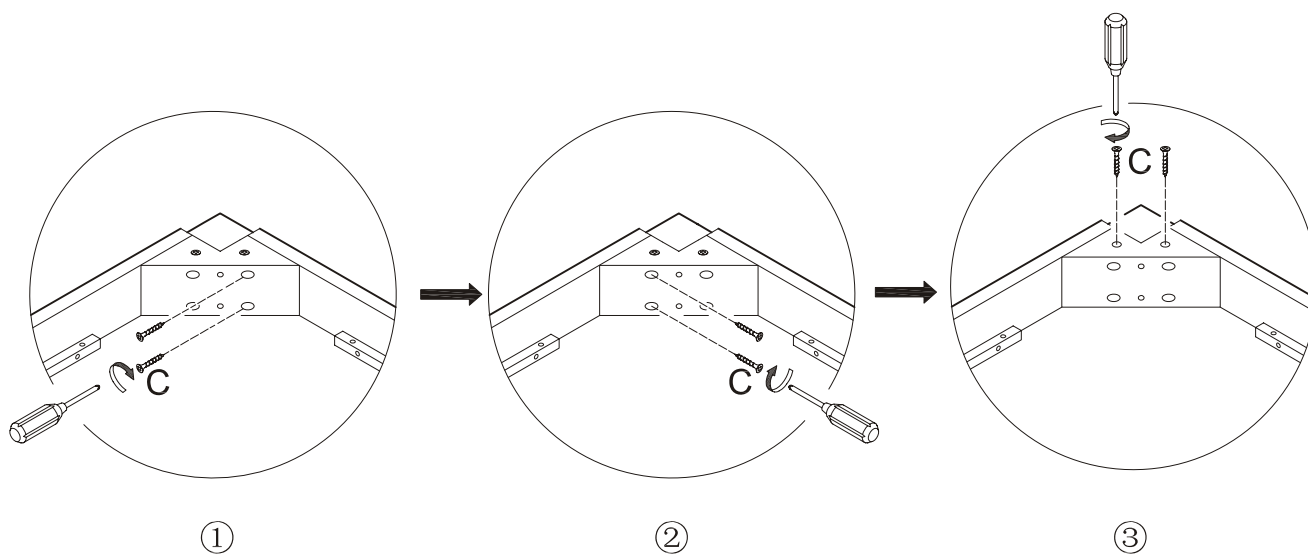

Secure corner blocks (6) to the table top assembly using screws (C). Apply pressure from the outside of the apron pieces while tightening screws (C) with a screwdriver.

## Step 9

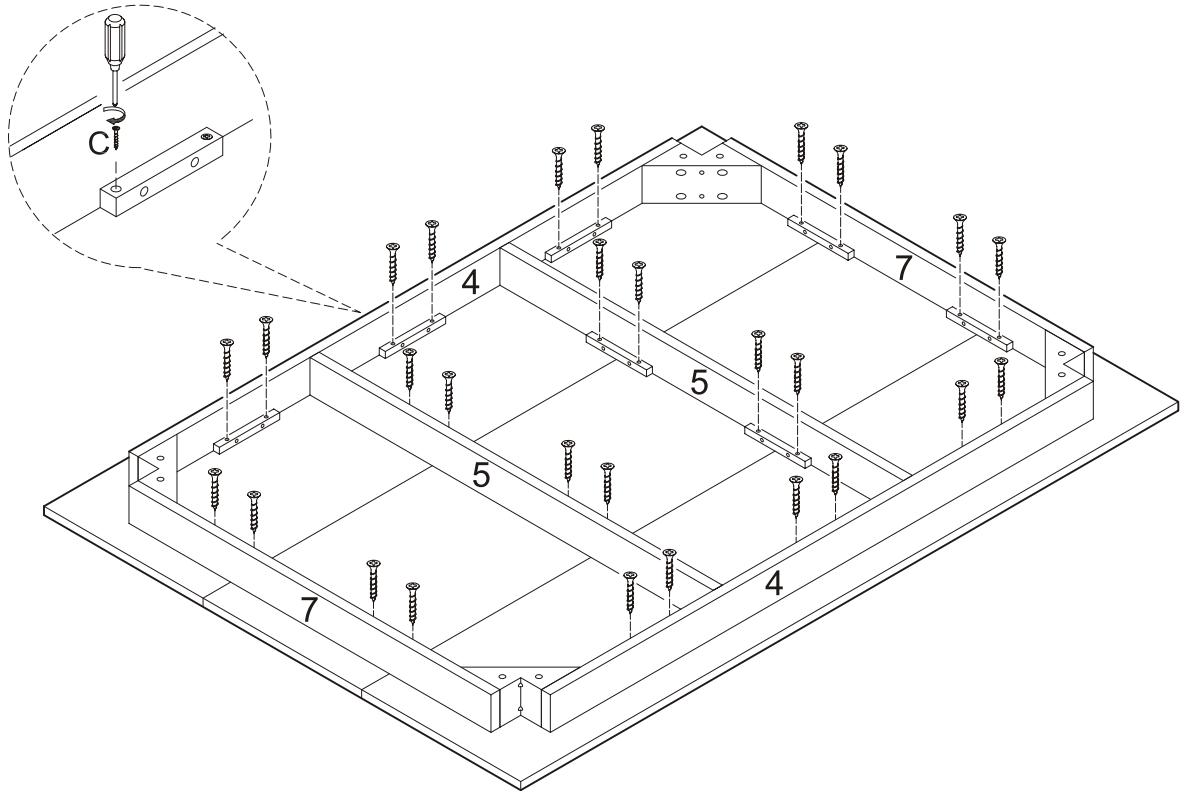

Secure aprons (4,5,7) to the table top using screws (C). Tighten screws (C) with a screwdriver.

## Step 10

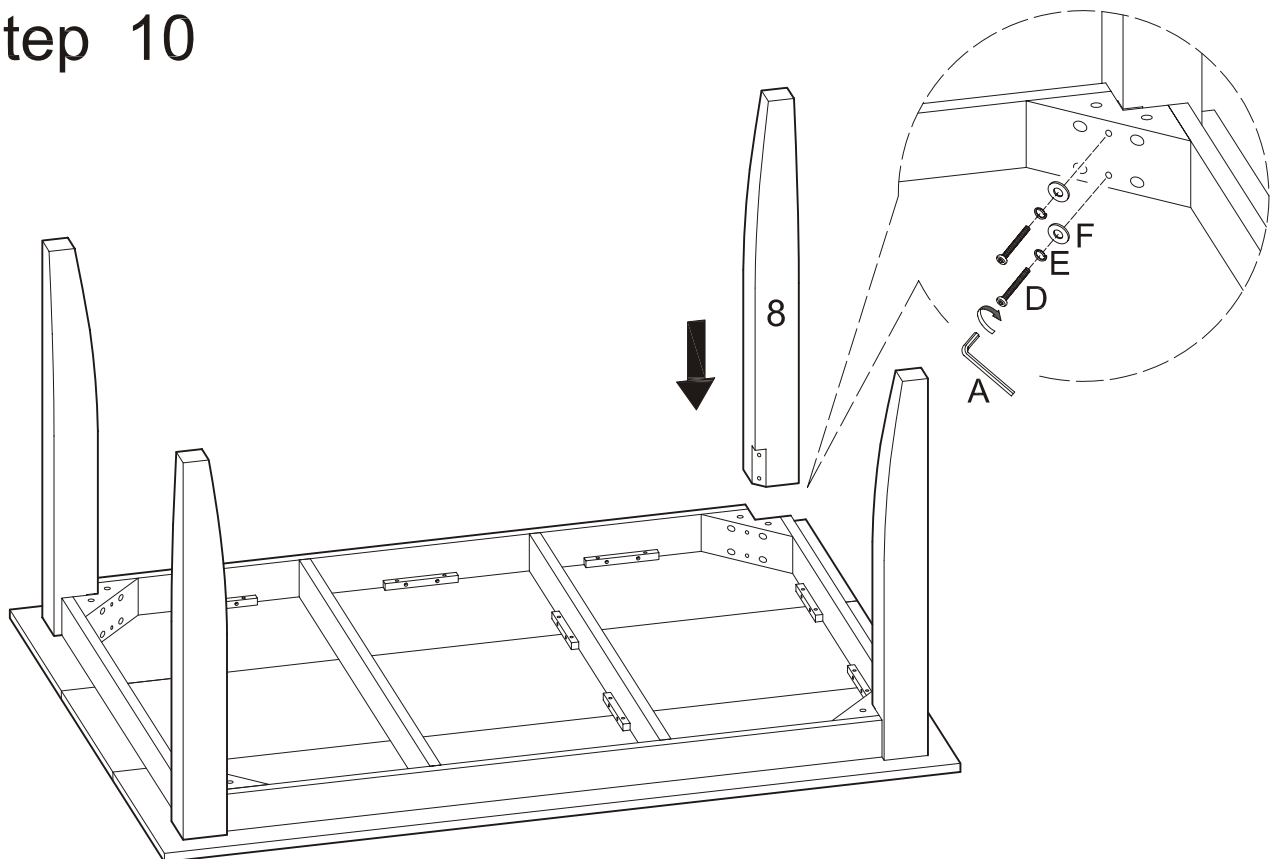

Attach table legs (8) to the table top assembly using bolts (D) and washers (E,F). Tighten bolts with wrench (A).

# Step 11

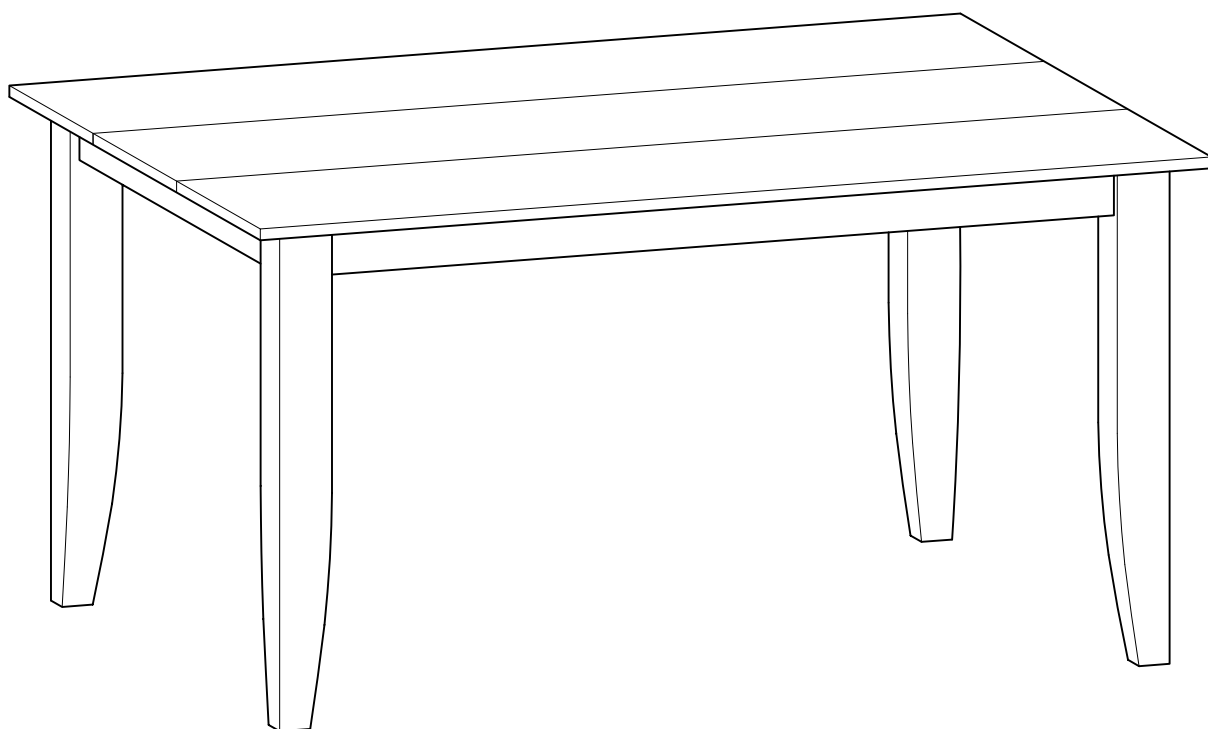

**Final Assembly**