

# ASSEMBLY INSTRUCTION & PARTS IDENTIFICATION COUNTER TABLE

HARDWARE KIT		
No.	Qty	Description
A	x 1	Allen Key M4 X 110mm
B	x 18	JCBC Bolt M6 X 50mm
C	x 5	JCBC Bolt M6 X 25mm
D	x 18	Spring Washer 1/4"
E	x 12	Lag Bolt
F	x 12	Lag Bolt Lock
G	x 4	Shelf Pin
H	x 3	Screw Cap

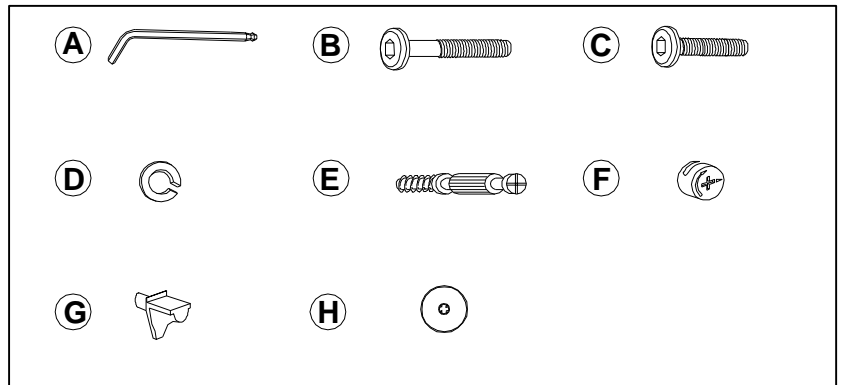

PART KEY		
No.	Qty	Description
1	1 pc	Table Top
2	2 pcs	Table Apron
3	1 pc	Left Leg Assembly
4	1 pc	Right Leg Assembly-Shelf Side
5	1 pc	Stretcher
6	1 pc	Storage Box Right Side
7	1 pc	Storage Box Left Side
8	1 pc	Storage Box Top
9	1 pc	Storage Box Bottom
10	1 pc	Fixed Shelf
11	1 pc	Adjustable Shelf
12	1 pc	Storage Box Back

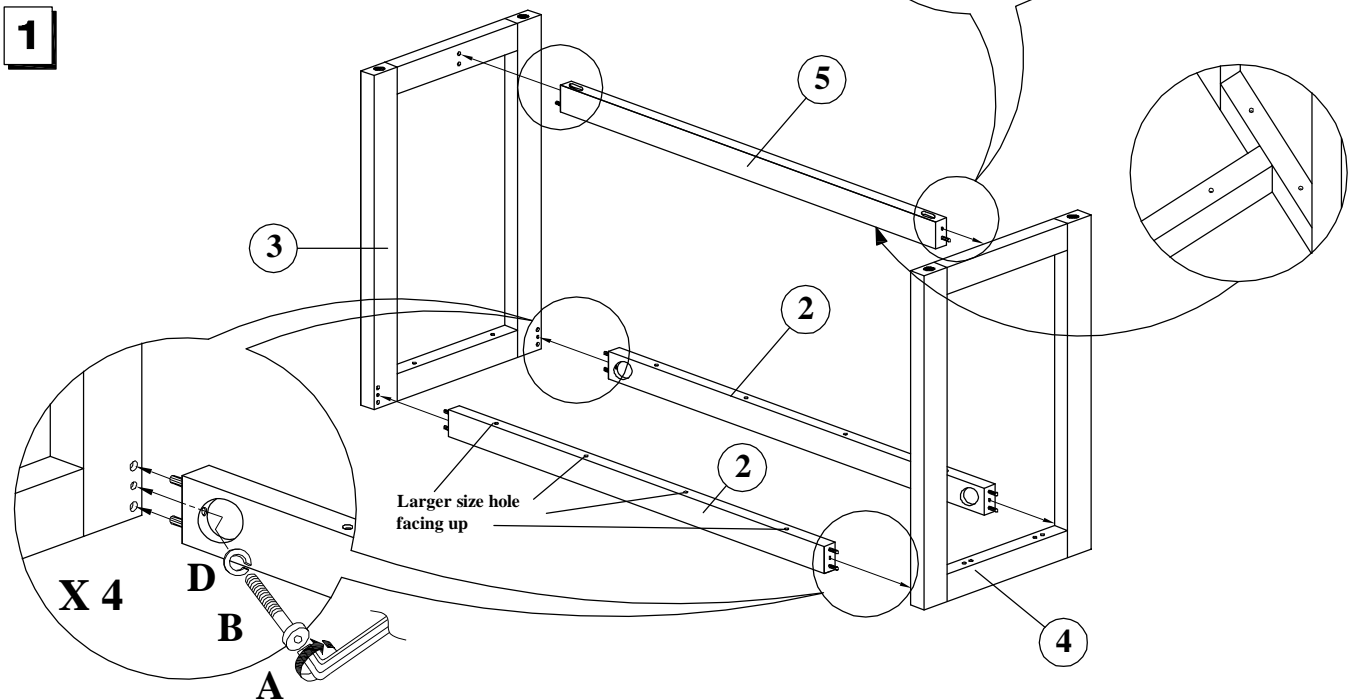
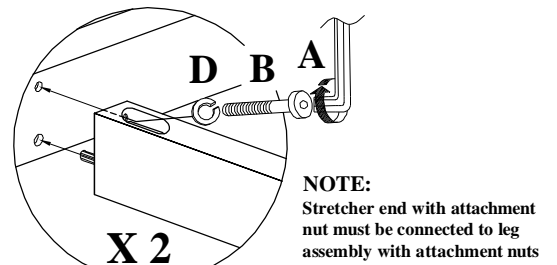

**2**

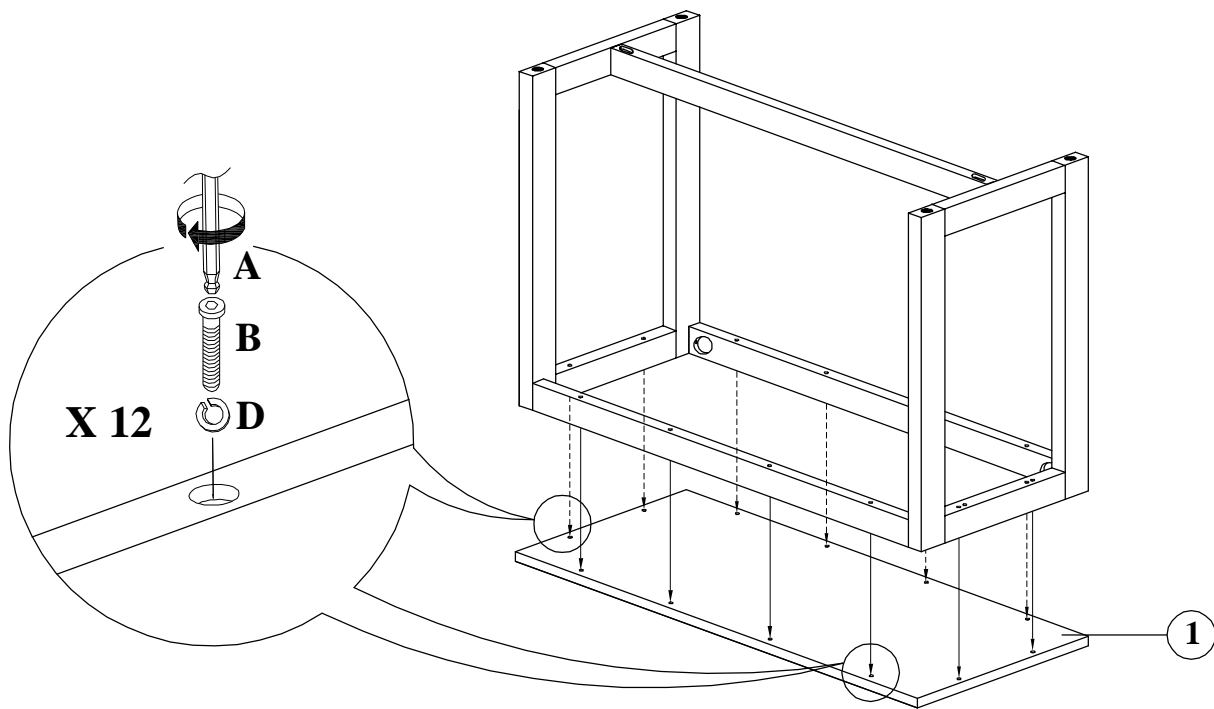

**3**

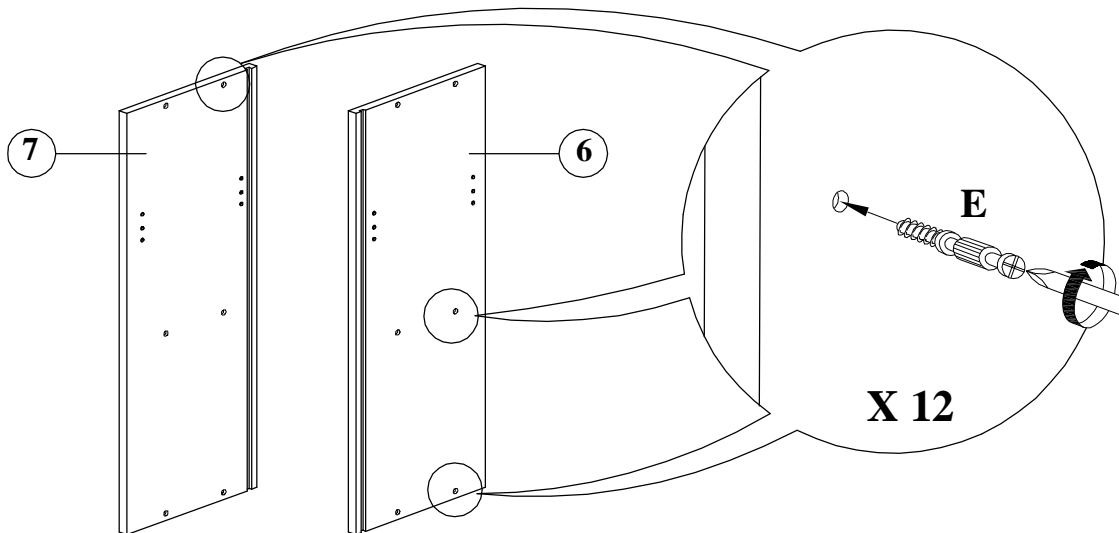

**4**

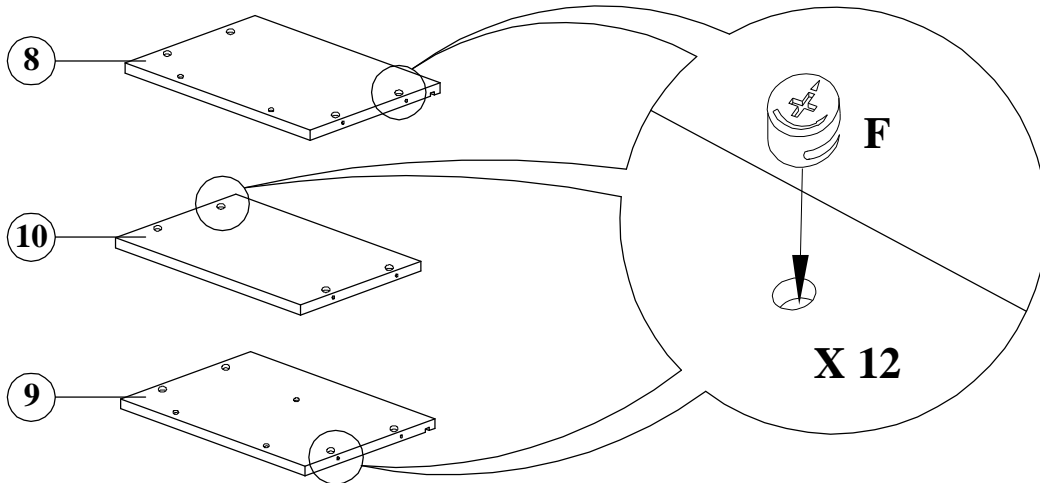

**5**

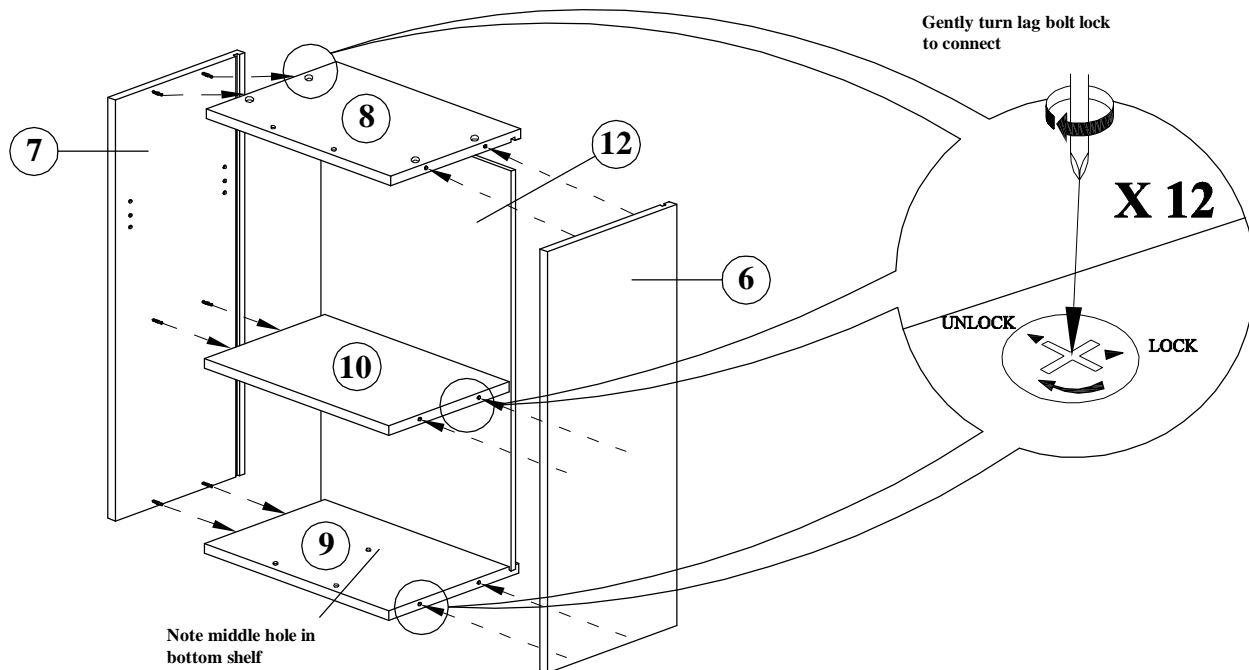

**6**

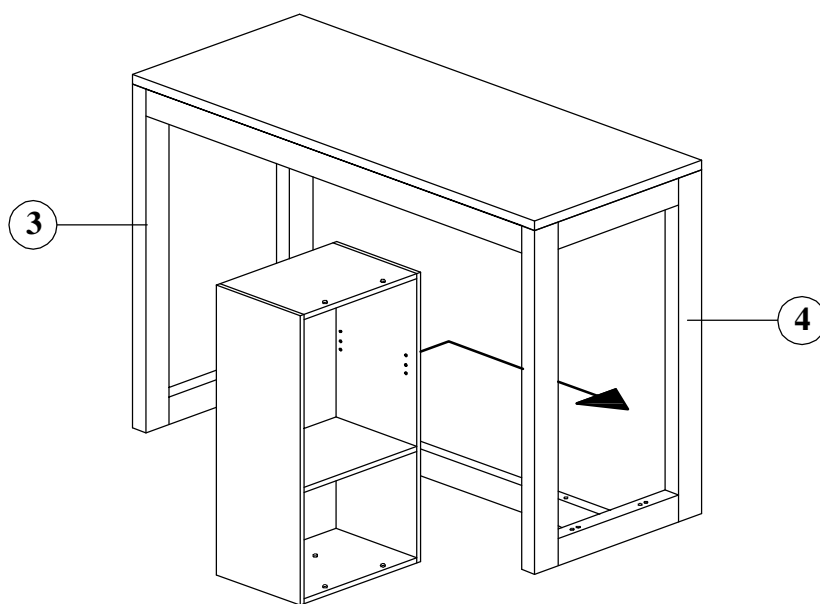

**7**

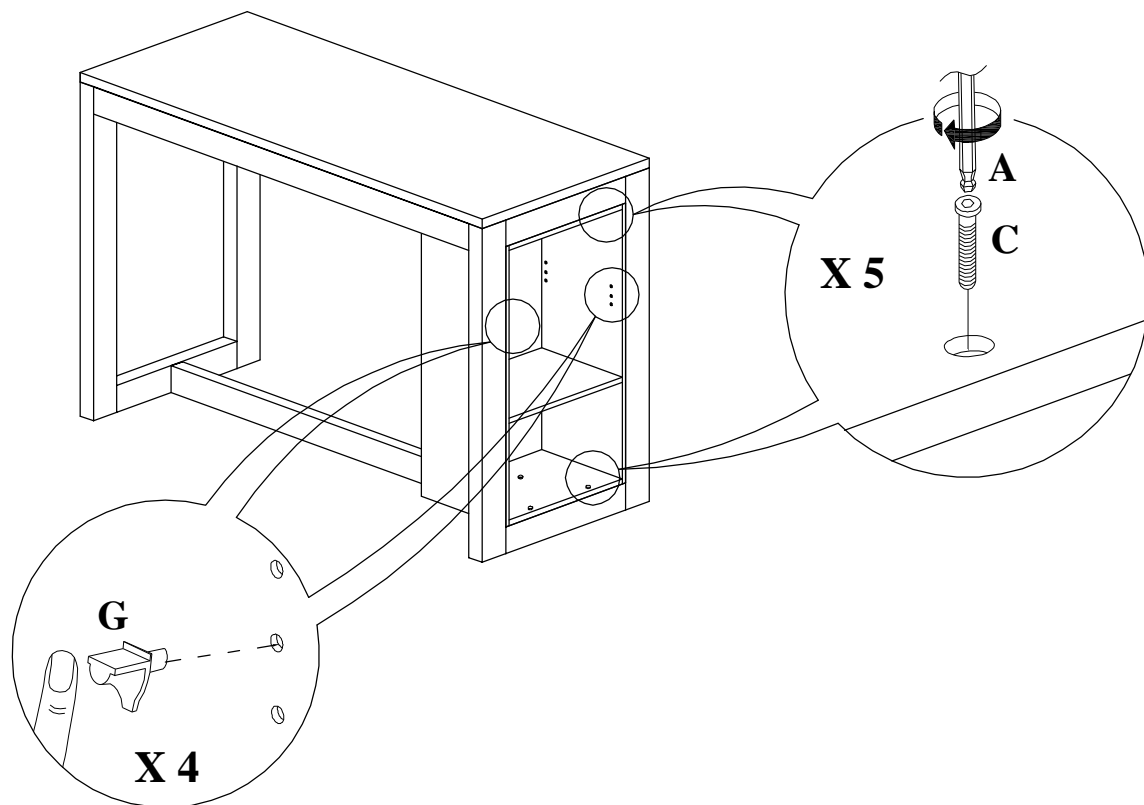

**8**

