

**essentialhome**<sup>TM</sup>

---

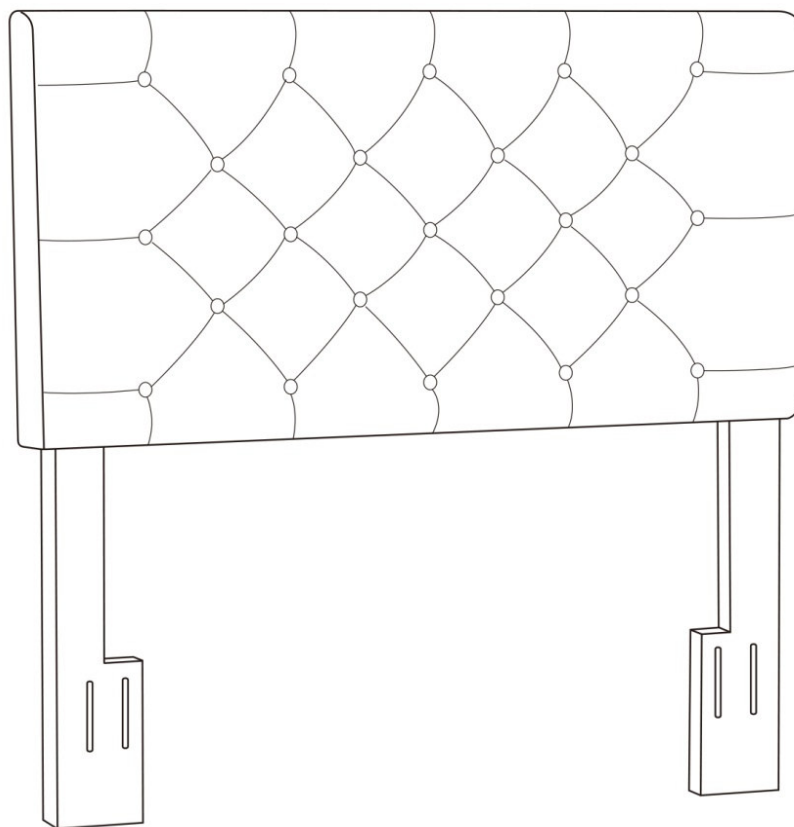

---

# OWNER'S MANUAL

## BUTTON TUFTED UPHOLSTERED HEADBOARD

Caution : This instruction booklet contains important safety information.

Please read and keep for future reference.

Product code: 0-07951984-9

UPC code: 0-65857-16891-4

Date of purchase: \_\_\_/\_\_\_/\_\_\_

## CUSTOMER SERVICE

If you are missing parts or have any questions about this product, contact our customer service representative first!



**CALL 1-800-295-1980**

You can also order parts by writing to the address listed below. Please include the product model number, color and a detailed description of the part.

**Customer Service Department No. 413**  
**12345 Albert-Hudon Boulevard, Suite 100**  
**Montreal, Quebec**  
**Canada H1G 3L1**  
**E-MAIL: [das@dorel.com](mailto:das@dorel.com)**

## NOTES

- \* Ensure all parts and components are present before beginning assembly.
- \* Assembly and handling will require two people.
- \* Assemble on a soft, smooth surface to prevent damage to the product finish.
- \* Read all instructions completely before assembly.
- \* **DO NOT** use power tools.
- \* **CAUTION:** Adult assembly required.
- \* Estimated assembly time: 15 minutes.
- \* The bed frame is not included and must be purchased separately.

## CARE AND CLEANING

Dust regularly with a soft, dry cloth to prevent soil build up. Keep away from heat to avoid glazing, melting or scorching. Use a professional cleaning service to clean the fabric.

## MAINTENANCE

Check bolts/screws periodically and tighten them if necessary.

## LIMITED WARRANTY

Dorel Asia warrants its product to be free from defects in material and workmanship and agrees to remedy any such defect. This warranty covers 1 year from the date of original purchase. This warranty is valid only upon presentation of proof of purchase. This is solely limited to the repair or replacement of defective furniture components and no assembly labor is included. This warranty does not apply to any product which has been improperly assembled, subjected to misuse or abuse or which has been altered or repaired in any way. Any wearing, tearing or fading of the fabric is not covered under the warranty. This warranty gives you specific legal rights and you may also have other rights which vary from State to State.







**WARNING: Should this product become damaged, and/or components are broken or missing, DO NOT USE.**

# BUTTON TUFTED UPHOLSTERED HEADBOARD

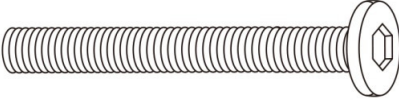
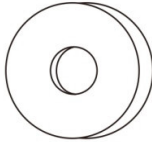
## DA31203

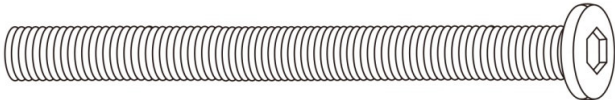
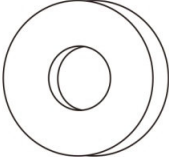

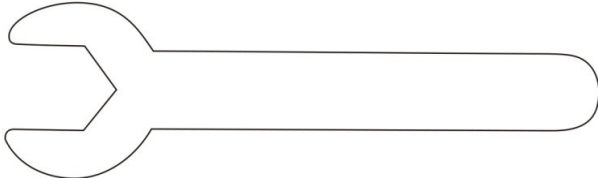
### HARDWARE LIST

<p>1</p>  <p>Ø1/4" X 2-1/8"</p>	<p>2</p>  <p>Ø3/4"</p>
<p>BOLT 8 PCS</p>	<p>FLAT WASHER 8 PCS</p>
<p>3</p>  <p>Ø5mm</p>	<p>4</p>  <p>Ø5/16" X 3-1/8"</p>
<p>ALLEN KEY 1 PC</p>	<p>BOLT 4 PCS</p>
<p>5</p>  <p>Ø7/8"</p>	<p>6</p>  <p>Ø1/2"</p>
<p>FLAT WASHER 8 PCS</p>	<p>SPRING WASHER 4 PCS</p>
<p>7</p>  <p>Ø5/16"</p>	<p>8</p> 
<p>NUT 4 PCS</p>	<p>WRENCH 1 PC</p>

# BUTTON TUFTED UPHOLSTERED HEADBOARD

## DA31203

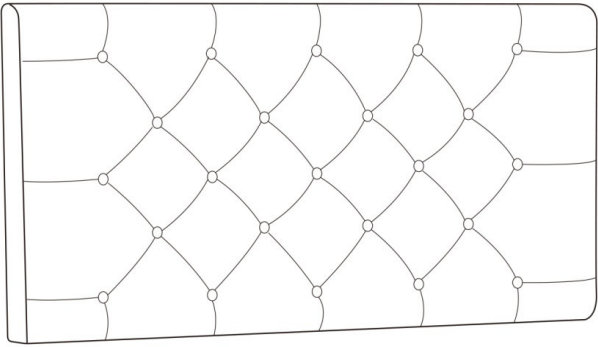
### PARTS LIST

<b>A</b> 	<b>B</b> 
HEADBOARD BODY 1 PC	LEG 2 PCS

NOTE: Legs (B) are packed inside headboard body (A). Pull back the fabric lining behind headboard body (A) to collect all parts

# BUTTON TUFTED UPHOLSTERED HEADBOARD DA31203

## STEP 1

Pull back the fabric lining behind headboard body (A) to collect legs (B).

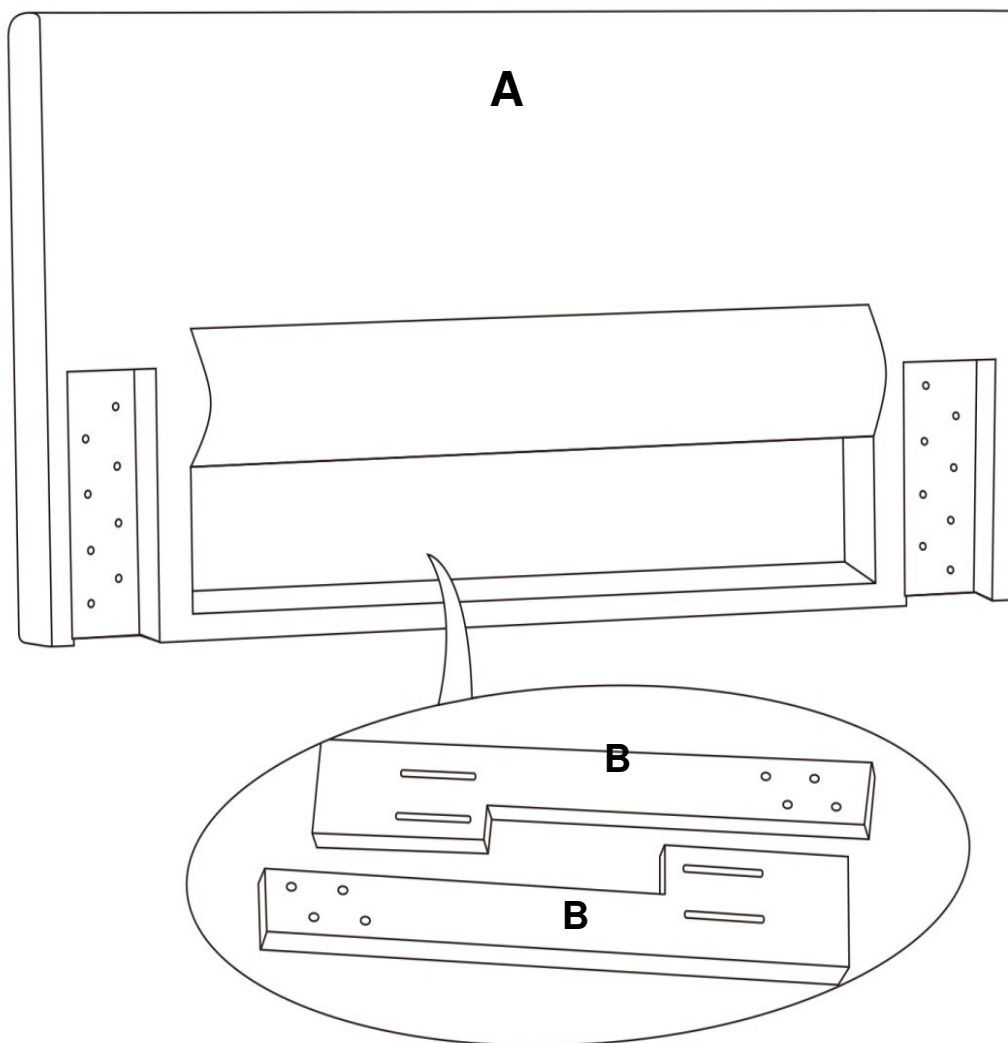

# BUTTON TUFTED UPHOLSTERED HEADBOARD DA31203

## STEP 2

Place all parts on a clean, smooth surface.

Attach legs (B) to headboard body (A) with bolts (1) and flat washers (2) and Allen Key (3).

**NOTE-** The headboard height can be adjusted to different heights. Select the desired height before attaching legs (B) to headboard body (A).

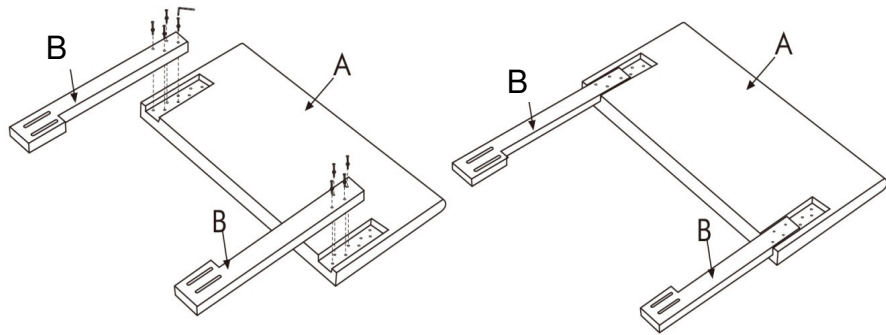
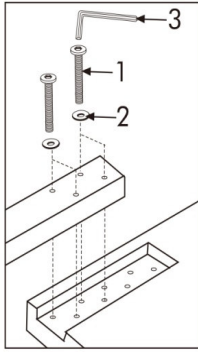

Attach the legs using the bottom hole to make the headboard high.

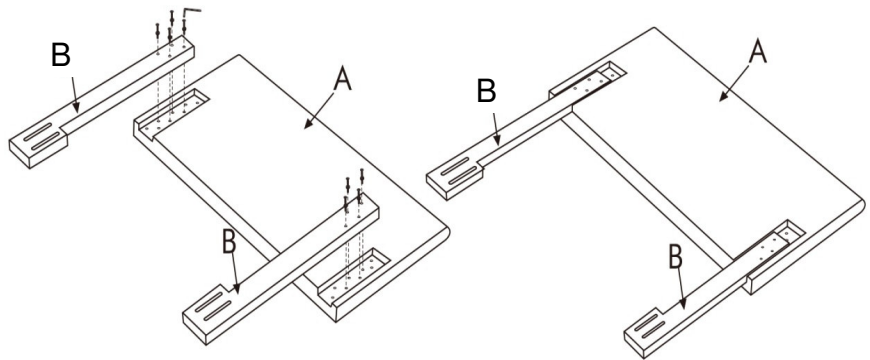
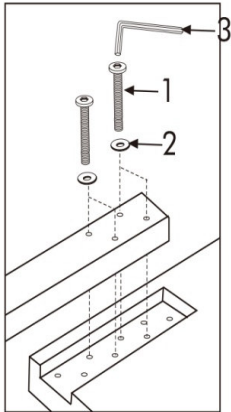

Attach the legs using the middle holes to make the headboard slightly lower.

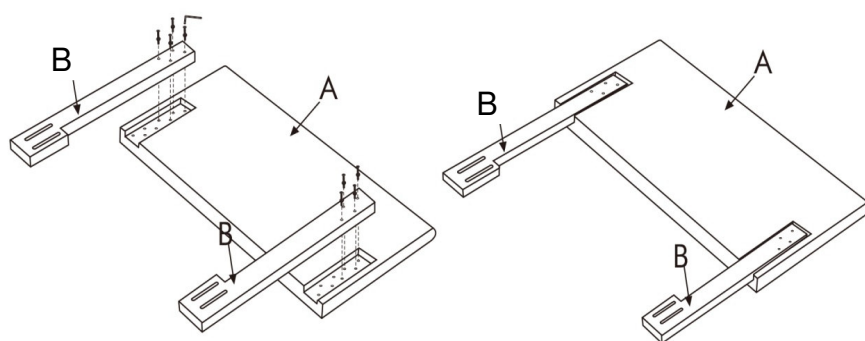
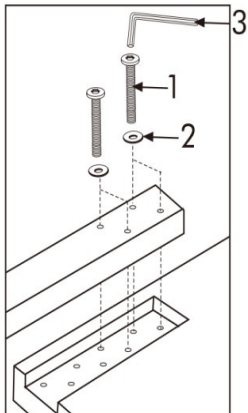

Attach legs using top holes to make the headboard low.

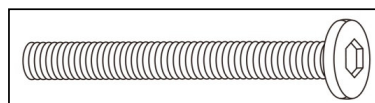

1

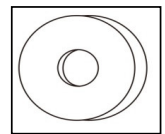

2

# BUTTON TUFTED UPHOLSTERED HEADBOARD DA31203

**NOTE: THE BED FRAME IS NOT INCLUDED AND MUST BE PURCHASED SEPARATELY. THE FOLLOWING ILLUSTRATIONS ARE FOR REFERENCE ONLY.**

Attach the bed frame (purchased separately) to legs (B) using bolts (4), spring washers (6), flat washers (5) and nuts (7) as shown below. Use Allen Key (3) to tighten bolts and use the open end wrench (8) to tighten the nuts (7).

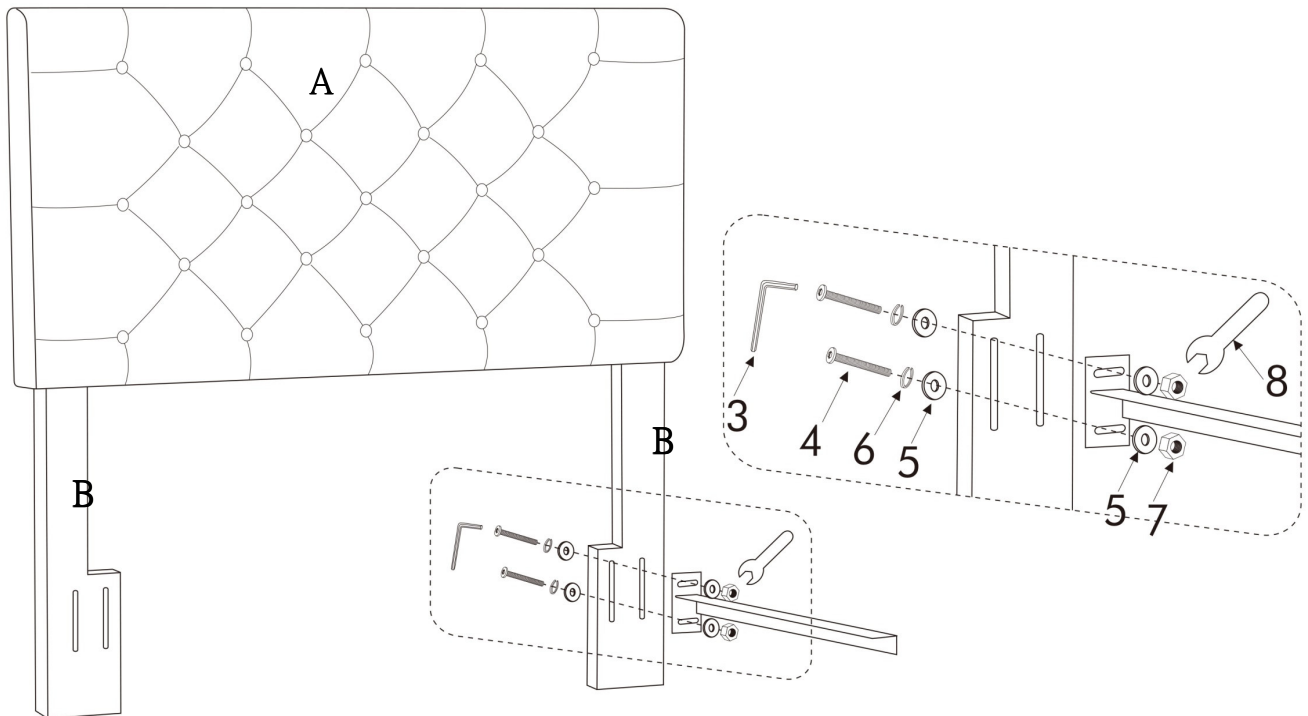

For a Queen Size Bed, attach the bed frame to the outer slots.  
For a Full Size Bed, attach the bed frame to the inner slots.

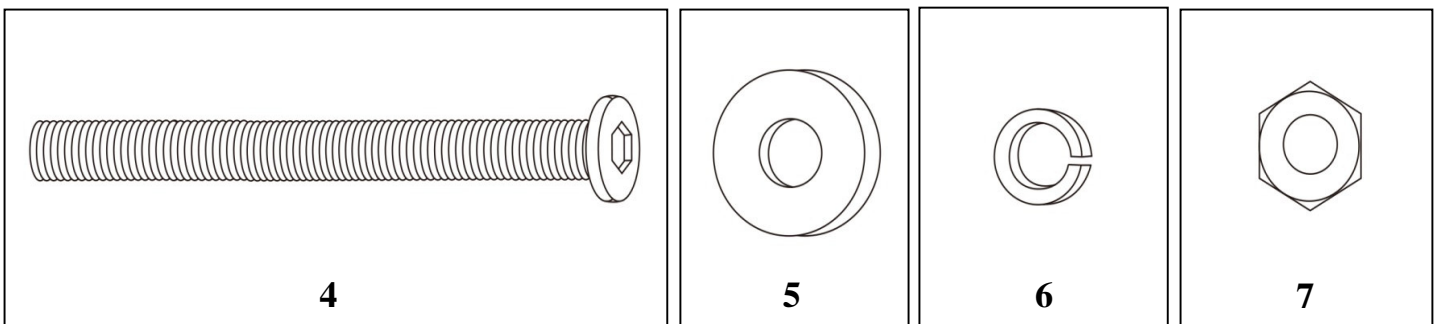

# BUTTON TUFTED UPHOLSTERED HEADBOARD DA31203

 **CAUTION:** This unit is intended for use only with the products and/or maximum weights indicated. Use with other products and/or products heavier than the maximum weights indicated may result in instability or cause possible injury.

Dust regularly with a soft, dry cloth to prevent soil build up. Keep away from heat to avoid glazing, melting or scorching. Use a professional cleaning service to clean the fabric.

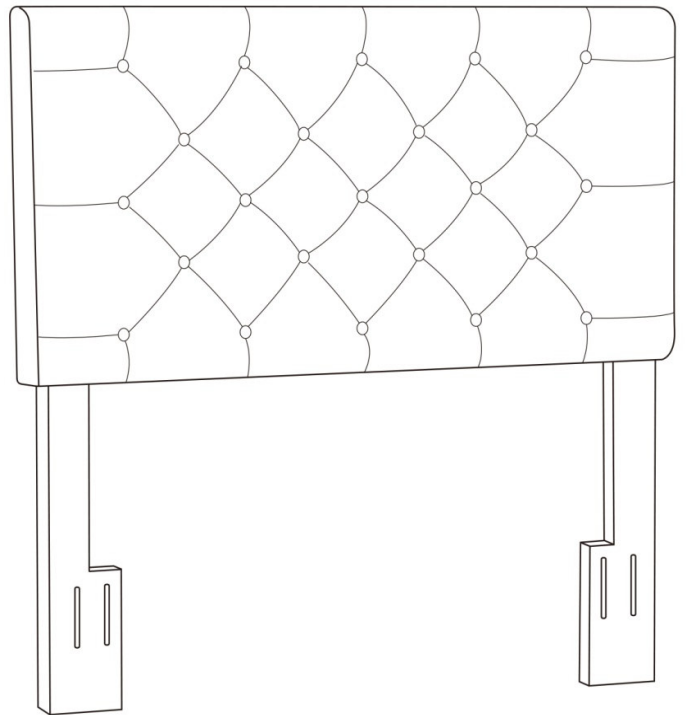

That's it! You've finished assembling your headboard.

**DO NOT RETURN PRODUCT TO THE STORE.**

If a part is missing or damaged, contact our customer service department. We will replace the part **FREE** of charge.



Tel #: 1-800-295-1980

E-Mail: [das@dorel.com](mailto:das@dorel.com)

Fax #: 514-353-7819



# Customer Service

**PLEASE DO NOT RETURN THIS PRODUCT TO THE STORE**

**PLEASE CONTACT CUSTOMER SERVICE REPRESENTATIVES AT THE FOLLOWING NUMBERS SHOULD THERE BE ANY MISSING OR DEFECTIVE PART(S).**

Customer Service Phone Number 1-800-295-1980

Email: [das@dorel.com](mailto:das@dorel.com)

Customer Service Fax Number 514-353-7819

Request Date:

Name:

Shipping Address:

Street & Number:

City & State:

Zip Code:

Day Time Phone Number:  
(including area code)

Date & Place of Purchase:

Part(s) description and quantity (Please be sure to list model number or SKN number):

Customer Service Representative Mailing Address:

Customer Service Department No. 413, 12345 Albert-Hudon Boulevard, Suite 100, Montreal, QC, Canada, H1G 3L1



Please refer to part numbers when reordering

For questions or comments about product:

Email: [das@dorel.com](mailto:das@dorel.com) or Call toll-free: 1-800-295-1980

Made in / Hecho en CHINA for Kmart Corporation, Hoffman Estates, IL 60179

SHOP [kmart.com](http://kmart.com)