

ASSEMBLY INSTRUCTIONS

IMPORTANT NOTE :

- * PLACE ALL WOODEN PARTS ON A CLEAN AND SMOOTH SURFACE SUCH AS A RUG OR CARPET TO AVOID THE PARTS FROM BEING SCRATCHED.
- * BEFORE YOU BEGIN, KINDLY FOLLOW THE ASSEMBLY INSTRUCTIONS STEP BY STEP.
- * DO NOT TIGHTEN ALL SCREWS UNTIL THE CHAIR IS FULLY SET-UP.

HARDWARE LIST		PART LIST				
A	JCBC M6 x 30mm + S/W M6 + F/W M6 x 13mm	4PCS	1 LEG FRAME (LEFT)	1PC		
	B		JCBC M6 x 50mm + S/W M6 + F/W M6 x 13mm	2PCS	2 LEG FRAME (RIGHT)	1PC
			C		ALLEN KEY M4	1PC
D	FH SCREW # 8 x 32mm	11PCS	3 FRONT RAIL	1PC		
			4 BACK RAIL	1PC		
			5 FRONT STRETCHER	1PC		
			6 BACK STRETCHER	1PC		
			7 TOP REST	1PC		
			8 CUSHION SEAT	1PC		

CAUTIONS :

(1) DO NOT FULLY-TIGHTEN THE NUT OR NUT BOLTS INITIALLY UNTIL ALL NUTS OR BOLT IS READY ASSEMBLED.

(TO AVOID CAUSING DAMAGES TO THE THREAD, DO NOT OVER-TIGHTEN THE NUTS OR BOLTS.)

(2) KEEP ALL HARDWARE PART OUT OF REACH OF CHILDREN.

STEP 1

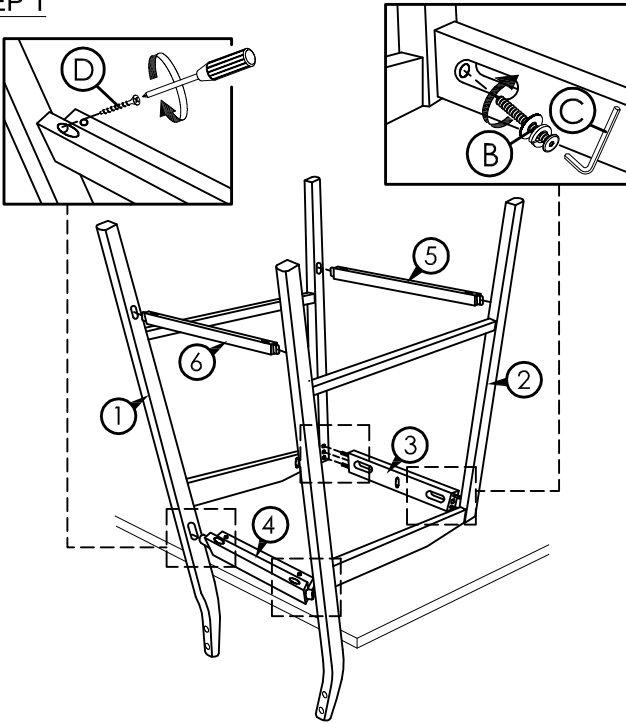

STEP 2

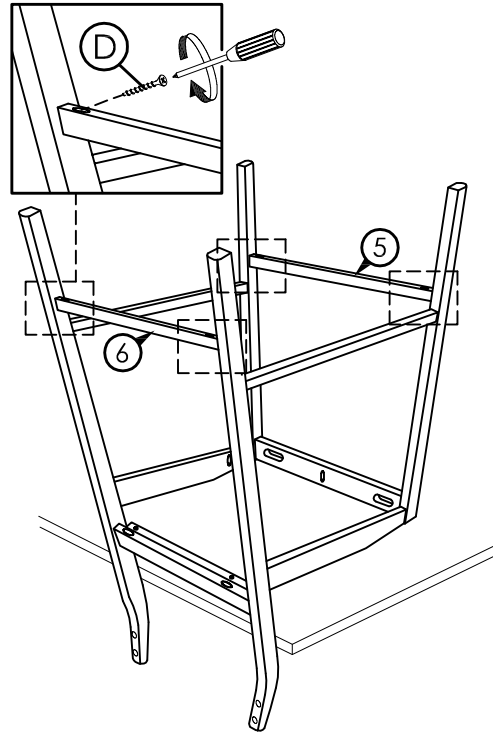

STEP 4

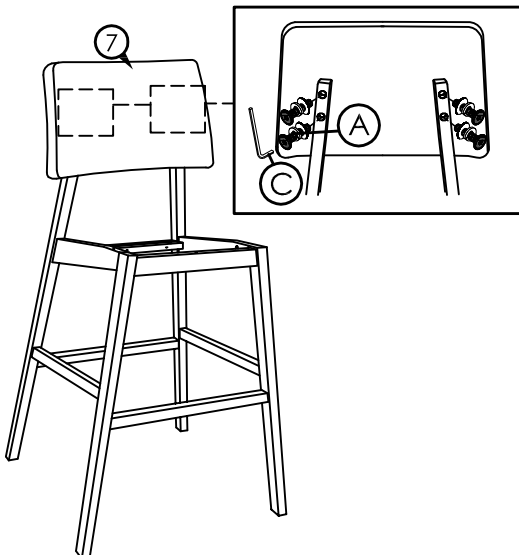

STEP 4

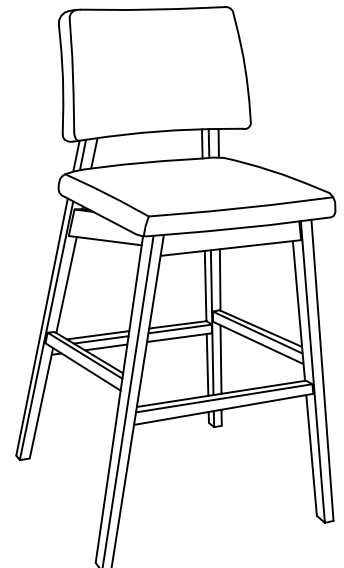
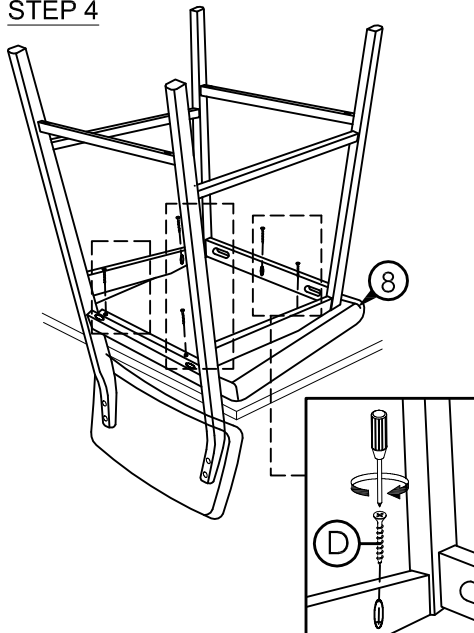

COMPLETED
BAR STOOL ASSEMBLY.