

Armchair

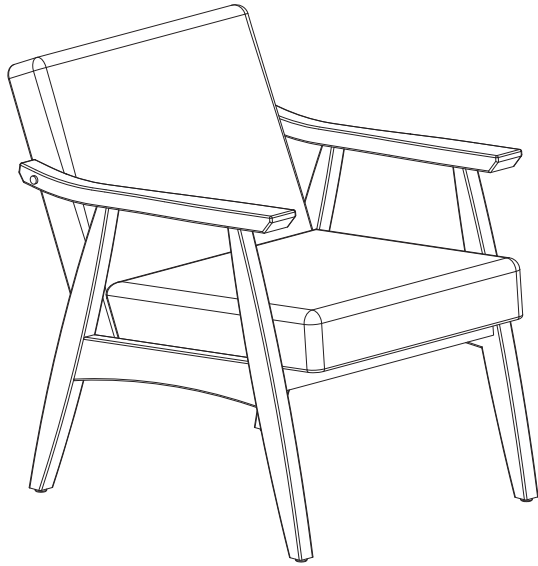

LIMITED WARRANTY

**Intended for residential use only*

Assembly Instructions - Important:

Carefully unpack and identify each component before attempting to assemble. Refer to parts list. Please take care when assembling the unit and always set the parts on a clean, soft surface.

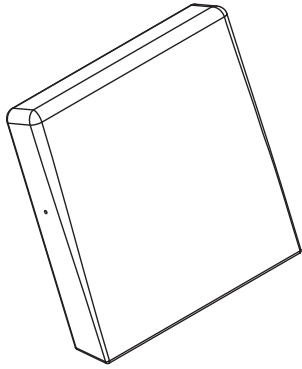

1 - (Back Cushion) - 1 Piece

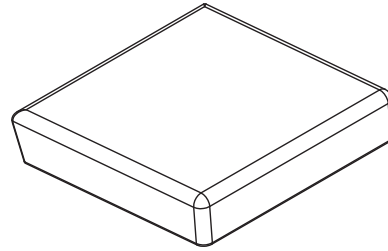

2 - (Seat Cushion) - 1 Piece

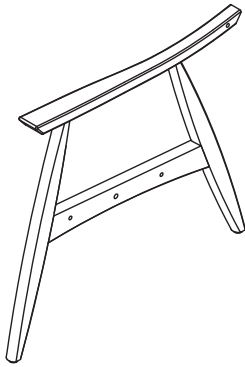

3 - (Right Arm Frame) - 1 Piece

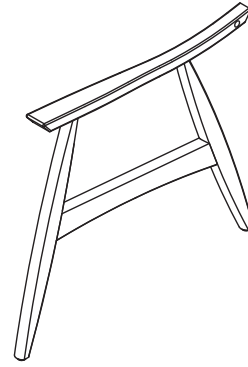



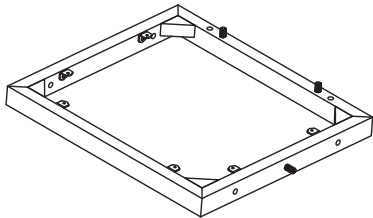



4 - (Left Arm Frame) - 1 Piece



5 - (Seat Frame) - 1 Piece

HARDWARE LIST

A		LONG BOLT	4 PCS + 1 Extra
B		SHORT BOLT	4 PCS + 1 Extra
C		FLAT WASHER	6 PCS + 1 Extra
D		LOCK WASHER	6 PCS + 1 Extra
E		WOOD SCREW	6 PCS + 1 Extra
F		WOOD PLUG	2 PCS + 1 Extra
G		ALLEN WRENCH	1 PC

Phillips screwdriver also required for assembly (not provided)

Step 1

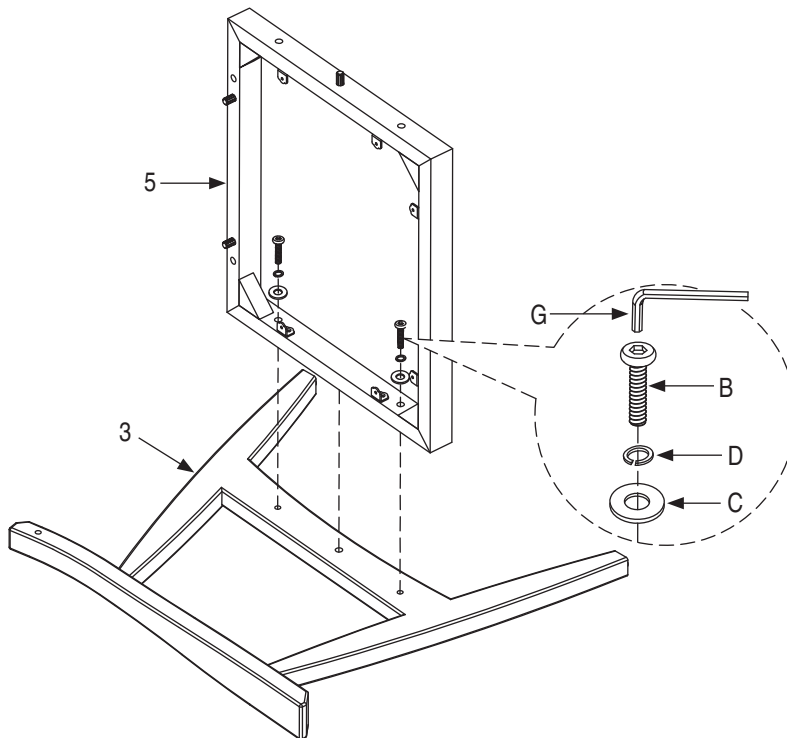

IMPORTANT NOTE: THREAD BOLTS SLIGHTLY. DO NOT FULLY TIGHTEN.

Step 2

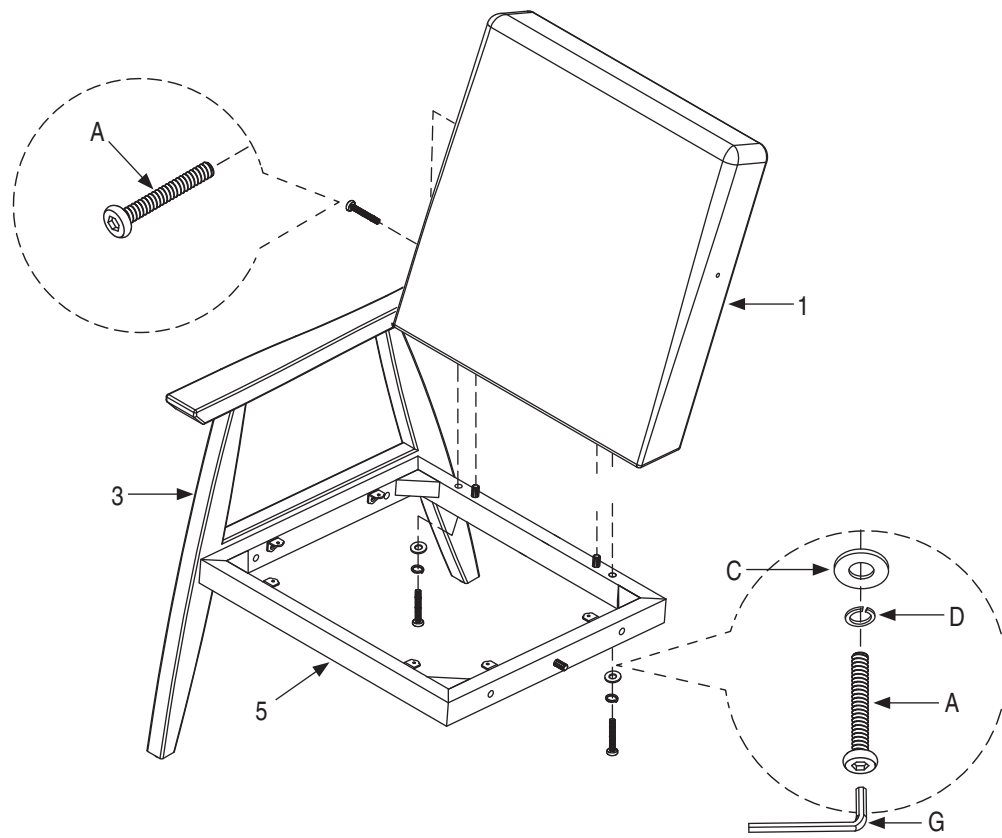

IMPORTANT NOTE: THREAD BOLTS SLIGHTLY. DO NOT FULLY TIGHTEN.

Step 3

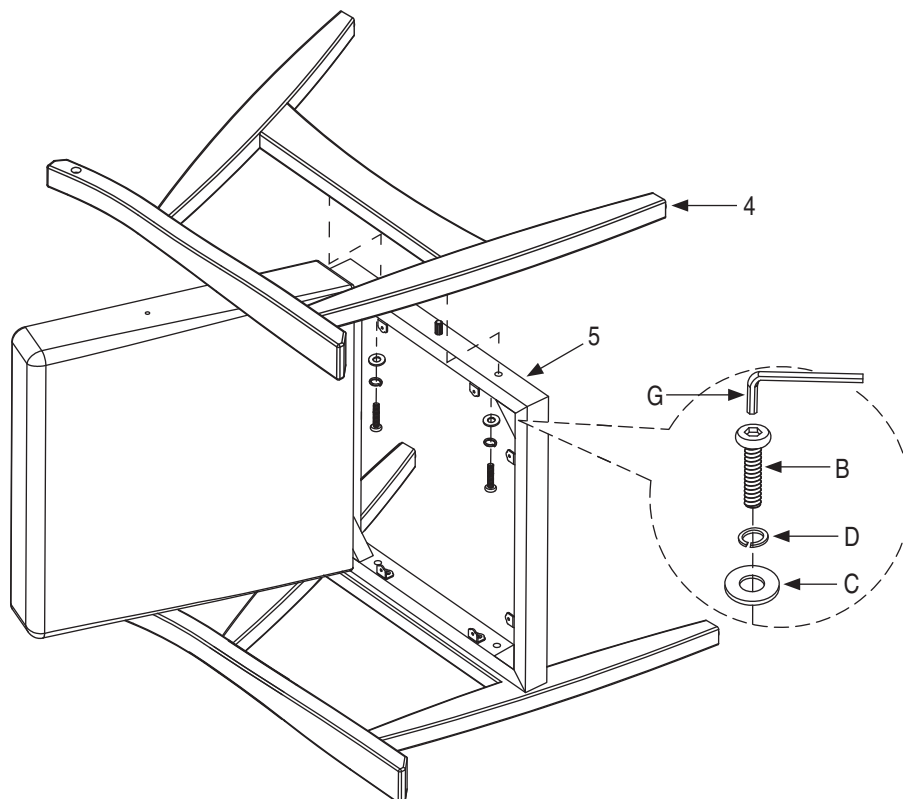

IMPORTANT NOTE: THREAD BOLTS SLIGHTLY. DO NOT FULLY TIGHTEN.

Step 4

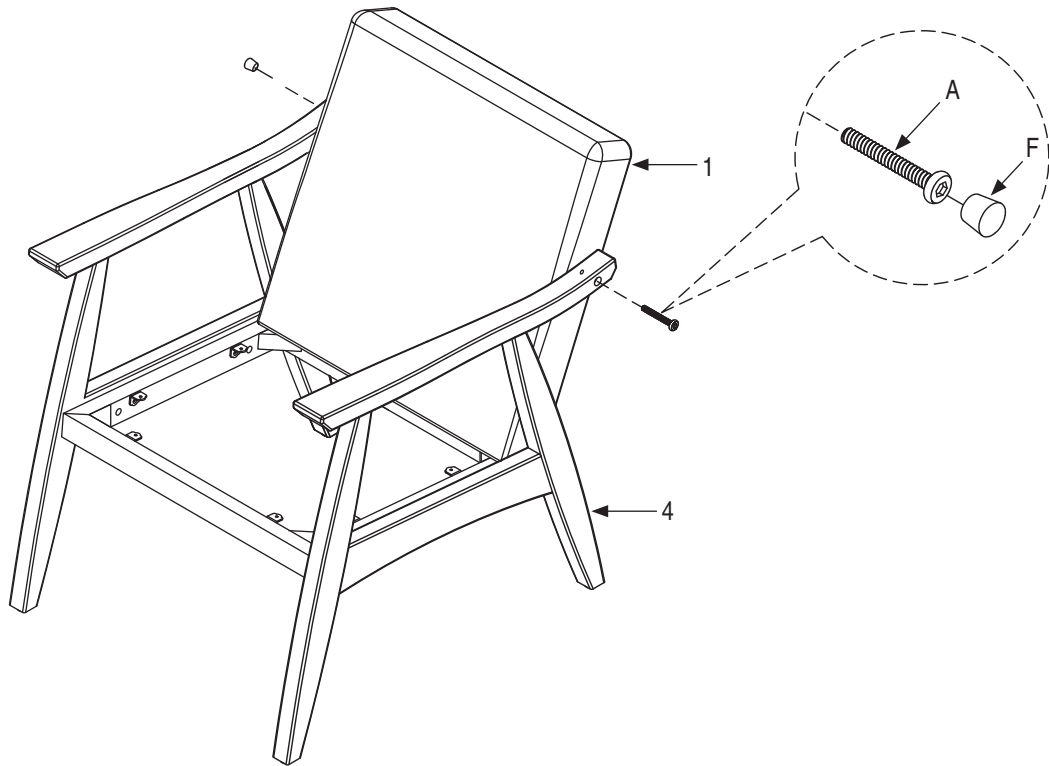

IMPORTANT NOTE: APPLY FIRM PRESSURE TO ALIGN HOLE IN BACK CUSHION (1) WITH HOLE IN LEFT ARM FRAME (4). **FULLY TIGHTEN ALL BOLTS.**

Step 5

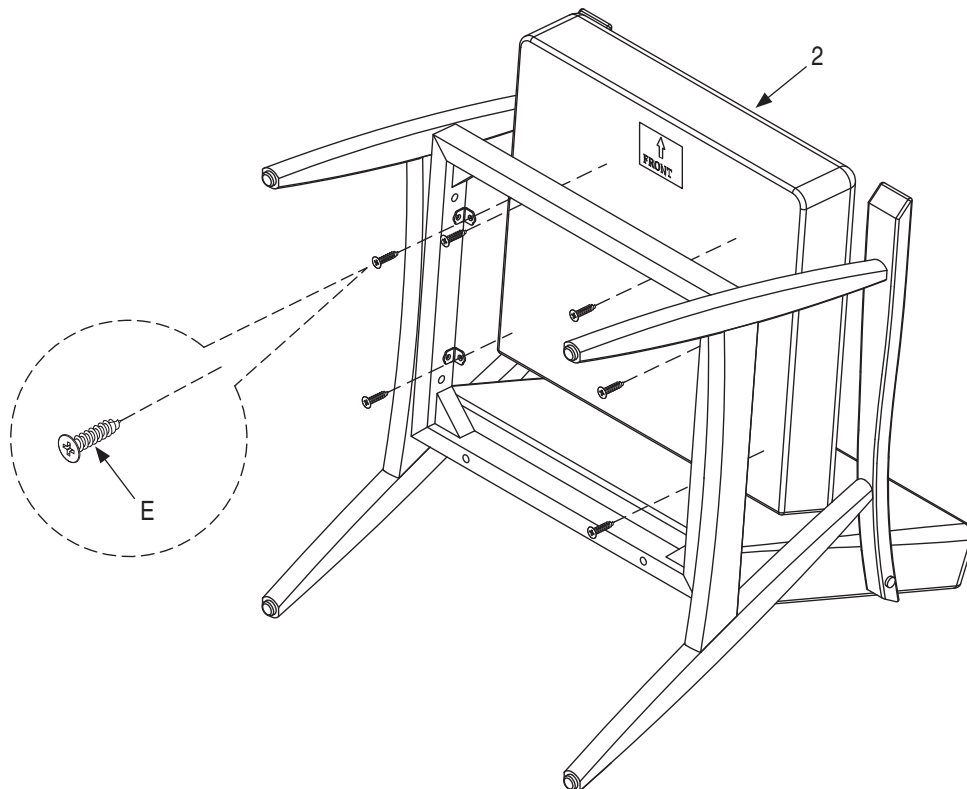

IMPORTANT NOTE: MAKE SURE **ALL BOLTS & SCREWS** ARE FULLY TIGHTENED BEFORE USING CHAIR.