











ASSEMBLY INSTRUCTION

NO	PART LIST	QTY
1	 HEADBOARD CUSHION	1PC
2	 RIGHT HEADBOARD LEG WITH 'R' LABEL	1PC
3	 LEFT HEADBOARD LEG WITH 'L' LABEL	1PC
4	 WINGS	2PCS
5	 FOOTBOARD CUSHION	1PC
6	 FOOTBOARD LEGS	2PCS
7	 SIDE RAIL	2PCS
8	 SIDE RAIL	2PCS
9	 SIDE RAIL SUPPORT LEG	2PCS
10	 SLATS	4PCS
11	 SUPPORT LEGS WITH ADJUSTABLE FEET	4PCS

STEP 1

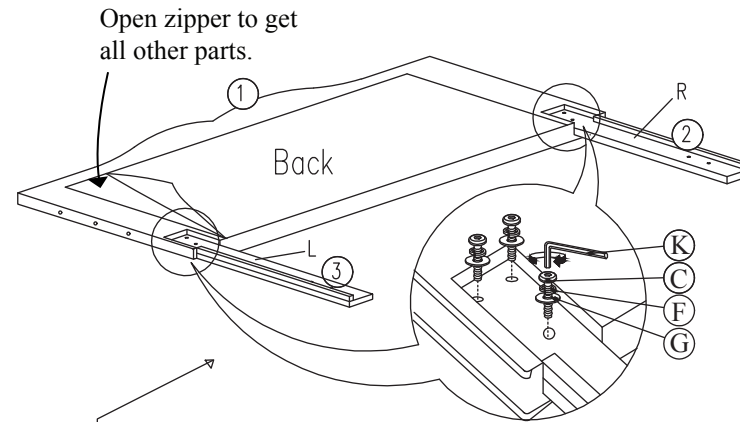

Make sure the cleat is on outside edge

STEP 2

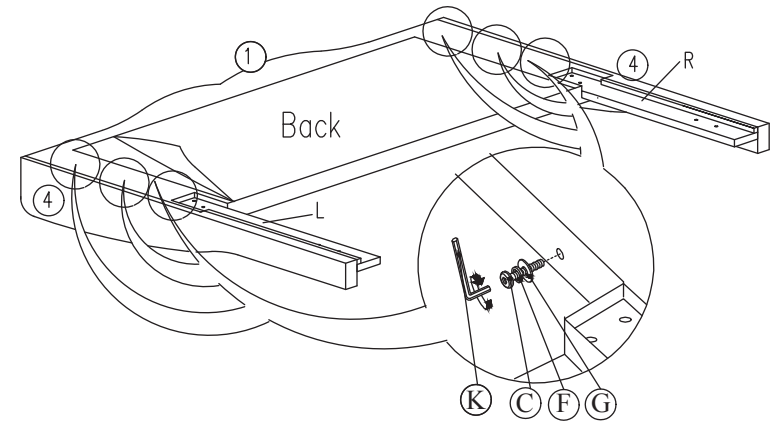



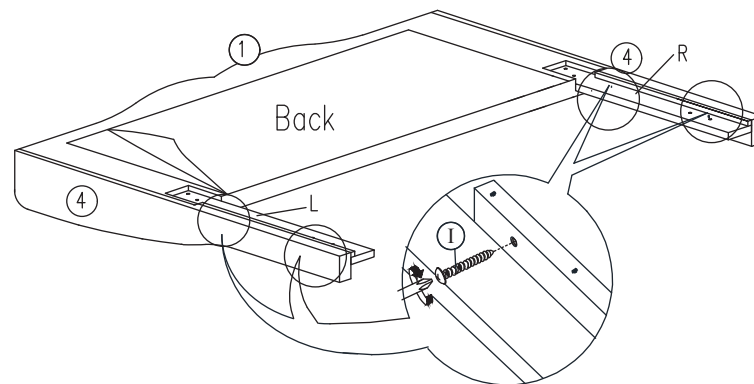



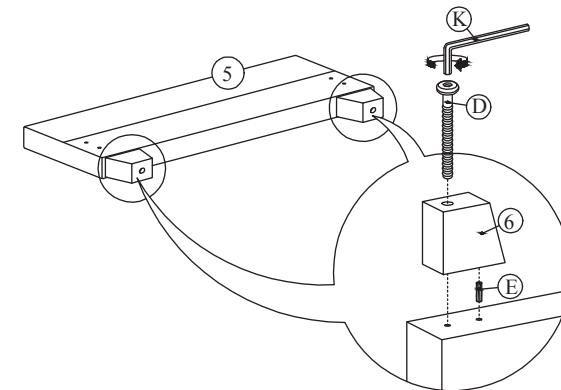



STEP 3



STEP 4



Do not fully tighten screws until assembly is complete and the bed is level

NO	HARDWARE LIST	QTY
A	 JCBB SCREW M8 X 20mm	8PCS
B	 JCBC SCREW M6 X 25mm	8PCS
C	 JCBC SCREW M6 X 35mm	16PCS
D	 JCBC SCREW M6 X 70mm	2PCS
E	 WOOD DOWEL M8 x 30mm	2PCS
F	 SPRING WASHER M6 x 13mm	20PCS
G	 FLAT WASHER M6 x 19mm	20PCS
H	 SCREW M4 X 32mm	8PCS
I	 SCREW M4 X 38mm	4PCS
J	 L - KEY M5 X 65mm	1PC
K	 L - KEY M4 X 65mm	1PC

ASSEMBLY INSTRUCTION

STEP 5

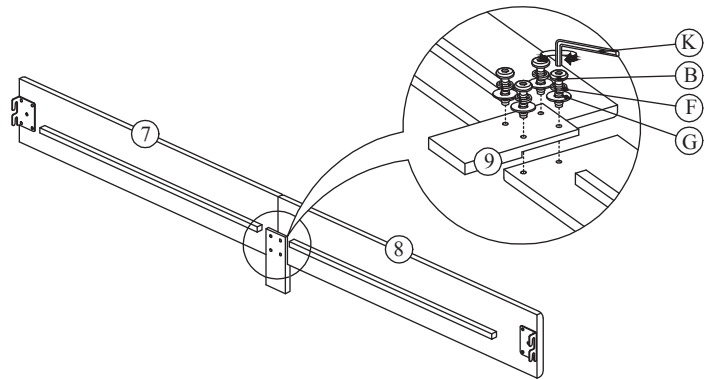

Do not fully tighten screws until assembly is complete and the bed is level

STEP 6

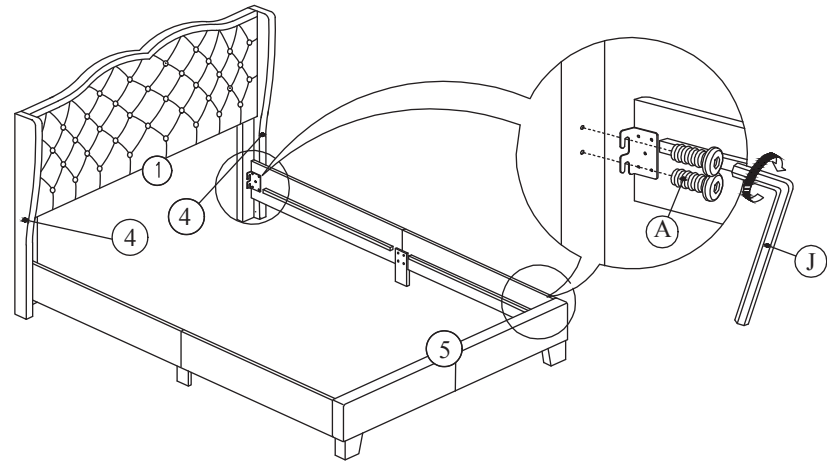

STEP 7

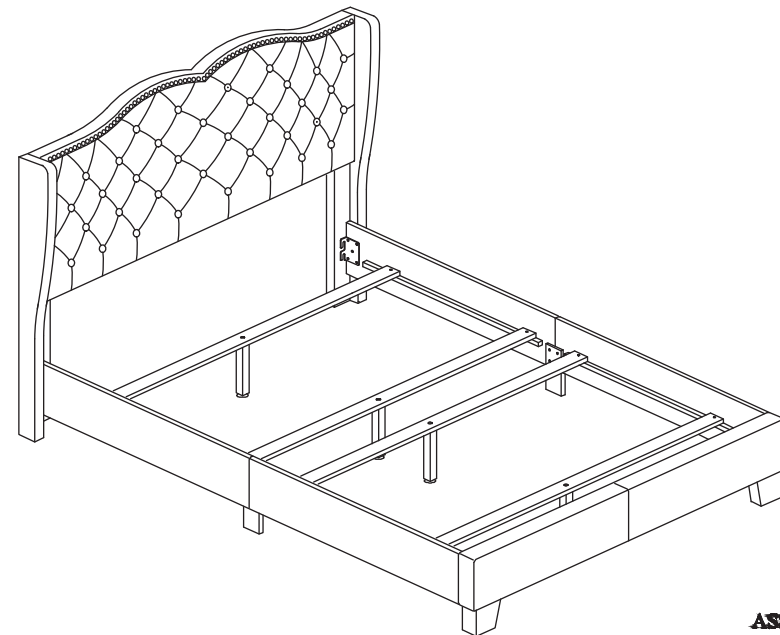
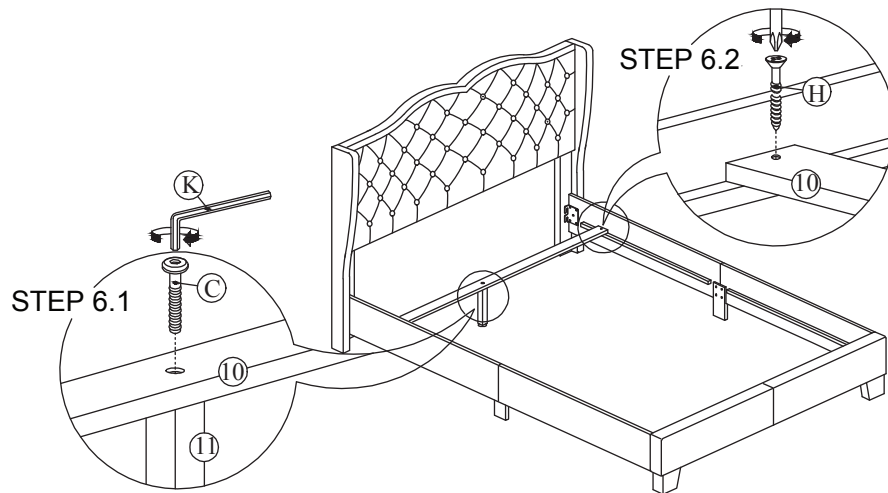

**ASSEMBLY
COMPLETED**

NOTE: AFTER A FEW DAYS OF ASSEMBLY, IT WILL HAVE ACCLIMATIZED TO THE ENVIRONMENT. PLEASE TIGHTEN ALL HARDWARE. CHECK TIGHTNESS OF ALL SCREWS EVERY 6 - 8 WEEKS.