

STEP 5

Attach Left/ Right Door (J&K) on Lower Shelf Panel (M) & Bottom Panel (N), as shown.

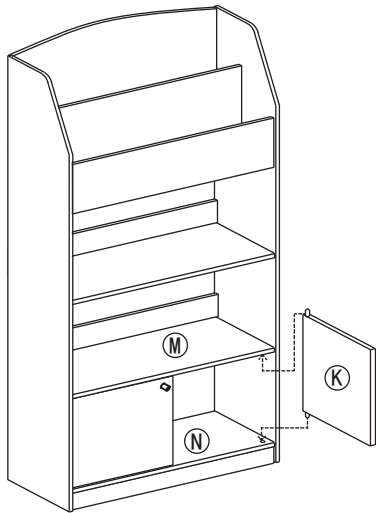

STEP 6

Attach L-Support (7) to assembled unit using Screw (7). Cover Screw Head with Stickers (8).

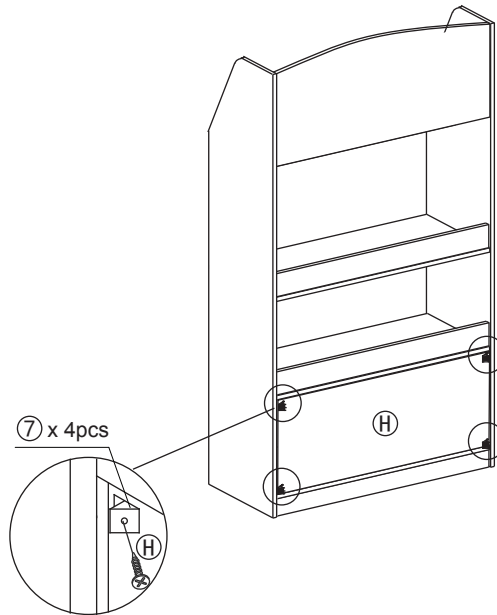

Recommended Maximum Weight

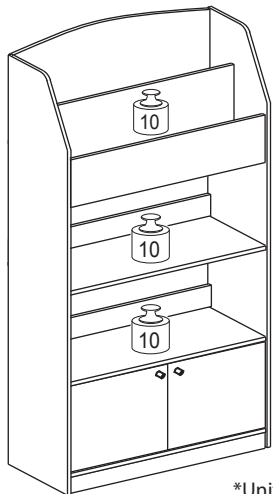

*Unit in Pound(lbs)

WARNING:

>This unit has been designed to support the maximum loads shown. Exceeding these load limits could cause sagging, instability, product collapse, and/or serious injury.

>DO NOT allow children to climb on unit.

>Put heavier items on lower shelves.



Assembly Instruction

Furinno Magazine/Bookshelf with Toy Storage Cabinet

MODEL : **FR16119**

00:30

Approx. 30 minutes



Recomm. 2 Person



Tool Required

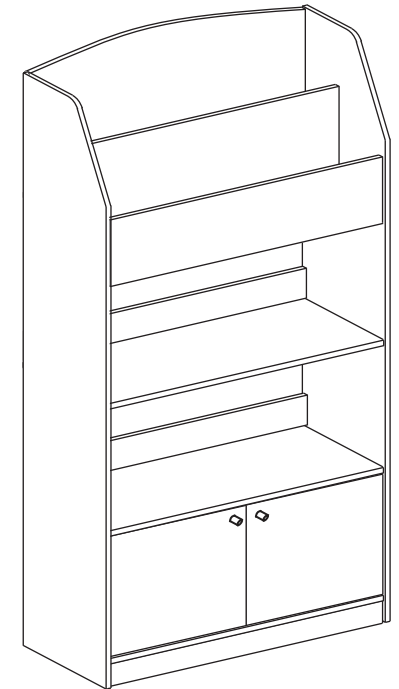























Customer Support

NEED HELP? For help with assembly, or if you are missing a part, please call Furinno Customer Service, 1-773-299-8111 from Mon-Fri, 9am-5pm (CST) or email: support@furinno.com

www.furinno.com



No.	Hardware List	Qty
1	Screw 	28pcs
2	Wood Dowel 	22pcs
3	Screw / Handle 	2pcs
4	Door Support 	4pcs
5	Door Catch / Screw 	1pc
6	Door Counter-piece / Screw 	2pcs
7	L-Support / Screw 	4pcs
8	Stickers 	24pcs

No.	Parts List	Qty
A	Left Panel 	1pc
B	Right Panel 	1pc
C	Large Divider Panel 	1pc
D	Medium Divider Panel 	1pc
E	Small Divider Panel 	1pc
F	Small Shelf Panel 	2pcs
G	Back Support Panel 	2pcs
H	Back Panel 	1pc
I	Front Support Panel 	1pc
J	Left Door 	1pc
K	Right Door 	1pc
L	Upper Shelf Panel 	1pc
M	Lower Shelf Panel 	1pc
N	Bottom Panel 	1pc

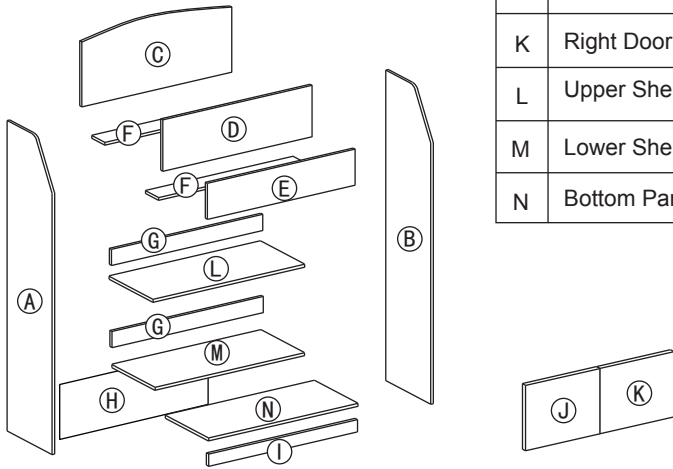

STEP 1

- 1.1 Attach Door Catch (5) on Bottom Shelf Panel (M) using Screw (5).
- 1.2 Attach Handle (3), Door Support (4) & Door Counter-piece (6) to Left / Right Door (J) (K) using Screw (3) & (6), as shown.

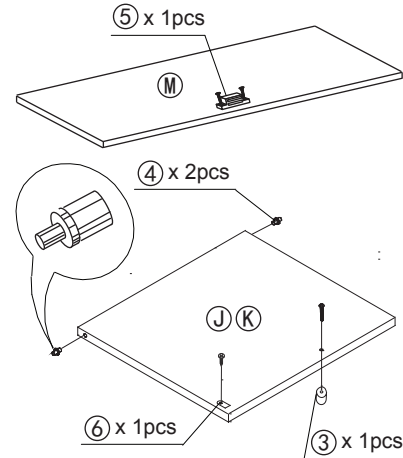

STEP 2

- 2.1 Attach Large Divider Panel (C) to Small Shelf Panel (F), Medium Divider Panel (D) to another Small Shelf Panel (F) using Screw (1).
- 2.2 Attach Upper / Lower Shelf Panel (L&M) to Back Support Panel (G) using Screw (1).
- 2.3 Attach Bottom Panel (N) to Front Support Panel (I) using Wood Dowel (2) as shown.

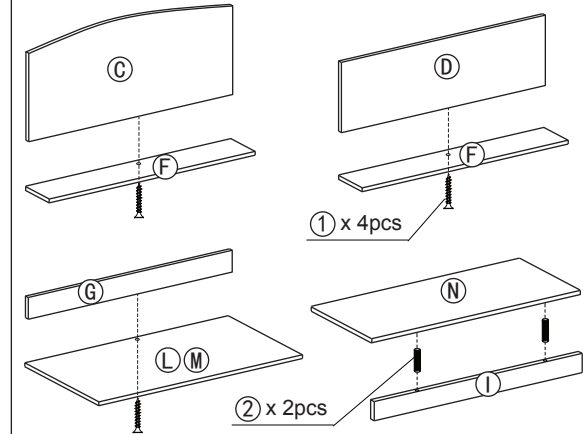

STEP 3

- 4.1 Insert Back Panel (H) to Lower Shelf (M) & Bottom Panel (N).
- 4.2 Attach Left Panel (A) to assembled unit using Screw (1) & Wood Dowel (2) as shown.

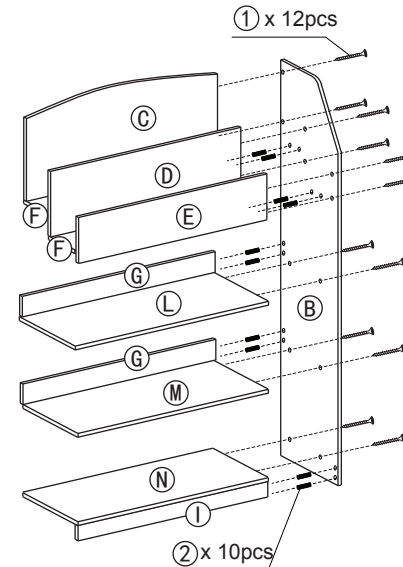

STEP 4

- 4.1 Insert Back Panel (H) to Lower Shelf (M) & Bottom Panel (N).
- 4.2 Attach Left Panel (A) to assembled unit using Screw (1) & Wood Dowel (2) as shown.

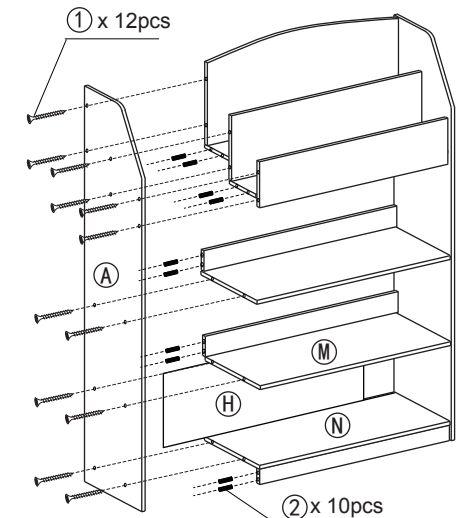

USEFUL HINTS BEFORE YOU START:

1. Read each step carefully before starting.
2. It is important that each step is performed in correct order to avoid difficulties.
3. Identify, sort and count the parts before assembly.
4. Assemble your furniture on packaging cardboard to prevent scratch or damage.
5. Clean the product with mild cleanser using soft damped cloth. Do not use harsh or abrasive cleanser.
6. Using incompatible hardware might cause damage to product.