

ASSEMBLY INSTRUCTIONS

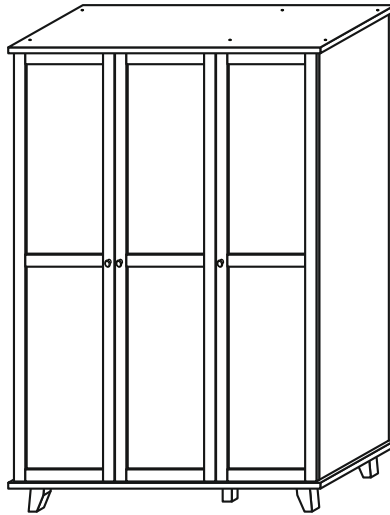

FOR DOMESTIC USE ONLY IMPORTANT

PLEASE READ BEFORE YOU CONTINUE FURTHER

THE PRODUCT YOU HAVE PURCHASED WILL GIVE YOU MANY YEARS OF SERVICE IF YOU FOLLOW THE GUIDELINES FOR ITS SAFE ASSEMBLY AND PERIODIC MAINTENANCE AND CLEANING.

ASSEMBLE ON A SOFT CLEAN SURFACE.

DO NOT USE ANY TOOLS OTHER THAN THOSE SHOWN.

ANY SPANNERS OR ALLEN KEYS REQUIRED ARE INCLUDED WITH THE FITTING KIT.

DO NOT FOR ANY REASON USE A POWER TOOL TO ASSEMBLE THIS PRODUCT. ITS USE WILL INVALIDATE ANY CLAIM YOU MAY HAVE AND COULD MAKE THIS PRODUCT UNSAFE.

**DEPENDING ON THE AMOUNT OF USE THIS PRODUCT RECEIVES IT MAY BE NECESSARY TO TIGHTEN UP THE FIXINGS FROM TIME TO TIME. THIS IS COMPLETELY NORMAL FOR ANY FLAT PACK FURNITURE.
DO NOT OVERTIGHTEN FIXINGS.**

FOR CLEANING, YOU MAY USE A DAMP CLOTH (NOT WET) DO NOT USE POLISH, DETERGENT OR CHEMICAL CLEANERS.

THE SURFACE OF THIS ITEM IS NOT HEAT RESISTANT. ALWAYS USE A PLACE MAT UNDER HOT OR COLD ITEMS TO PREVENT MARKING.

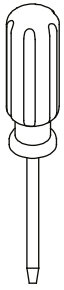

(Screwdriver not provided)

Use a flat blade screwdriver to tighten the cam nuts. A quarter turn clockwise is all that is needed.

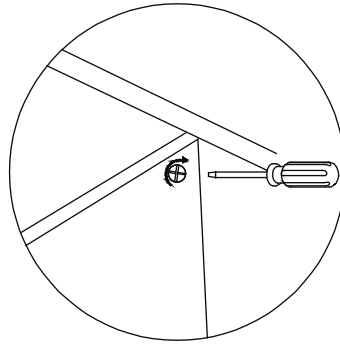

This is how a cam nut works....

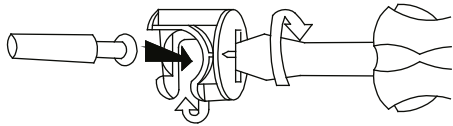

The head of the bolt goes into the wide mouth of the cam nut. You then turn the nut so the narrow part closes over the bolt.

TWO PERSONS REQUIRED TO ASSEMBLE THIS PRODUCT

1. Please check that you have all the parts listed before you start assembling. If you do find that something is missing, do not continue assembly. Please contact your supplier immediately.
2. Lay out all of the components on a soft surface as if you were preparing to do a jigsaw puzzle.
3. Separate and identify each component, from the hardware pack and rest each one in its proper location before fastening.

THE USE OF POWER TOOLS TO ASSEMBLE THIS PRODUCT WILL INVALIDATE ANY CLAIM AND MAY DAMAGE THIS PRODUCT MAKING IT UNSAFE

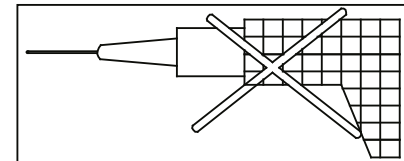

PARTS LIST

HARDWARE LIST

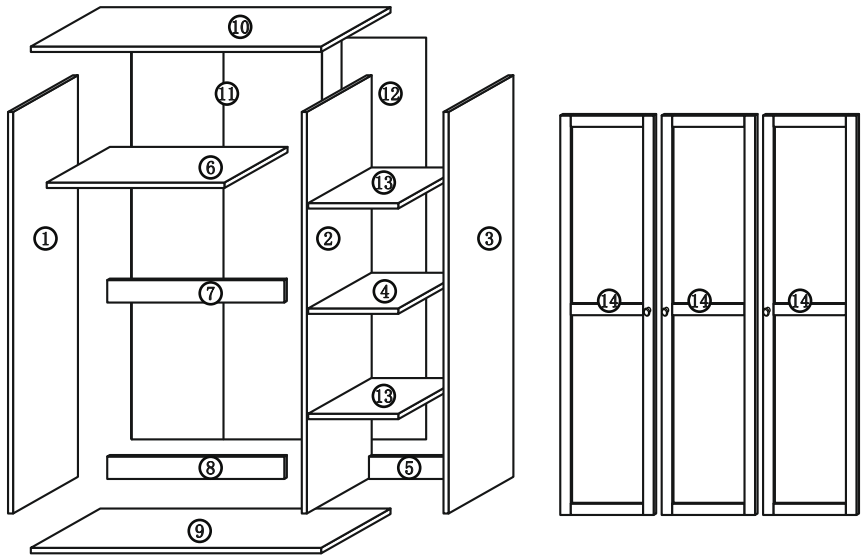

A		7 x 43MM CAM PIN & CAM LOCK	18PCS
B		HANDLE & BOLT	3PCS
C		8 x 30MM DOWEL	36PCS
D		WALL FIXING	2PCS
E		5 x 40MM SCREW	14PCS
F		3 x 12MM SCREW	42PCS
G		METAL CONNECTOR	5PCS
H		SHELF SUPPORT	8PCS
I		HANGING RAIL SUPPORT	2PCS
J		HANGING RAIL	1PC
K		3.5 x 14MM SCREW	40PCS
L		HINGE	6PCS
M		FOOT & BOLT	4PCS
N		MIDDLE DOOR HINGE	3PCS
O		FOOT & BOLT	1PC

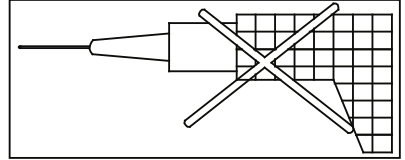

1	LEFT HAND SIDE PANEL	1PC	8	BOTTOM LEFT CROSSBEAM	1PC
2	MIDDLE PANEL	1PC	9	BOTTOM PANEL	1PC
3	RIGHT HAND SIDE PANEL	1PC	10	TOP PANEL	1PC
4	SMALL FIXED SHELF	1PC	11	LEFT / MIDDLE BACK PANEL	1PC
5	BOTTOM RIGHT CROSSBEAM	1PC	12	RIGHT BACK PANEL	1PC
6	LARGE FIXED SHELF	1PC	13	ADJUSTABLE SHELVES	2PCS
7	MIDDLE LEFT CROSSBEAM	1PC	14	LEFT / MIDDLE / RIGHT DOOR PANEL	3PCS

THE USE OF POWER TOOLS TO ASSEMBLE THIS PRODUCT WILL INVALIDATE ANY CLAIM AND MAY DAMAGE THIS PRODUCT MAKING IT UNSAFE

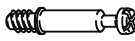

STEP 1

You will need:-

A		12PCS
I		1PC
K		2PCS

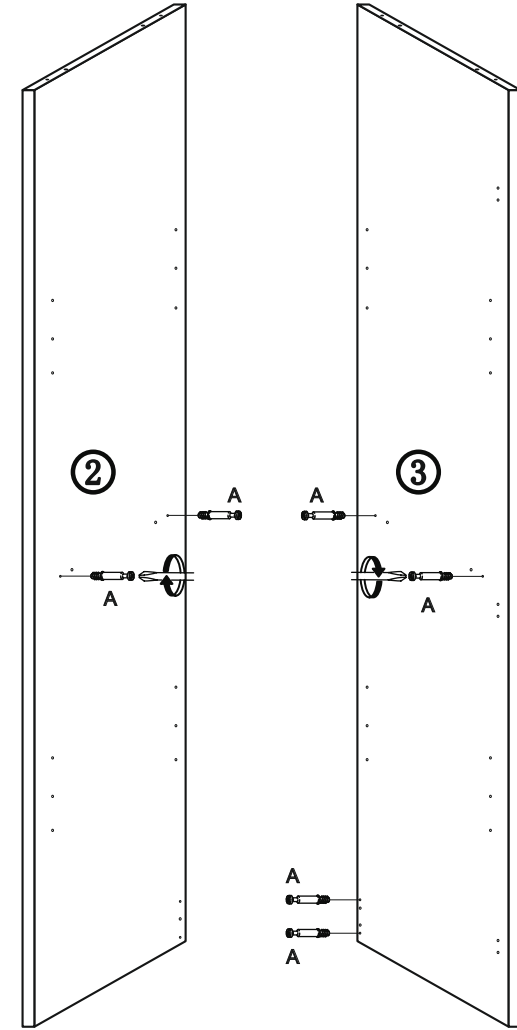
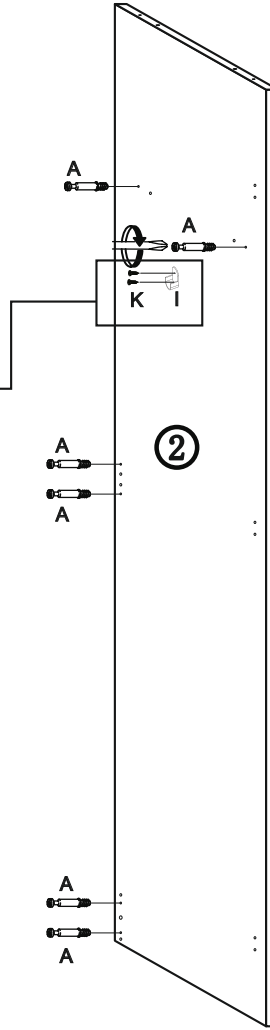
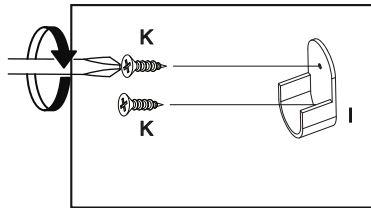

NOT PROVIDED

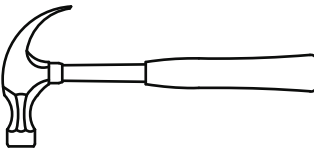
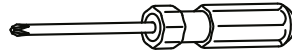

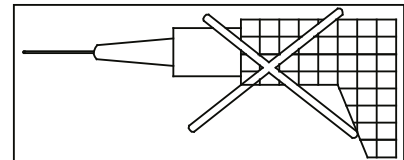

THE USE OF POWER TOOLS TO ASSEMBLE THIS PRODUCT WILL INVALIDATE ANY CLAIM AND MAY DAMAGE THIS PRODUCT MAKING IT UNSAFE



STEP 2

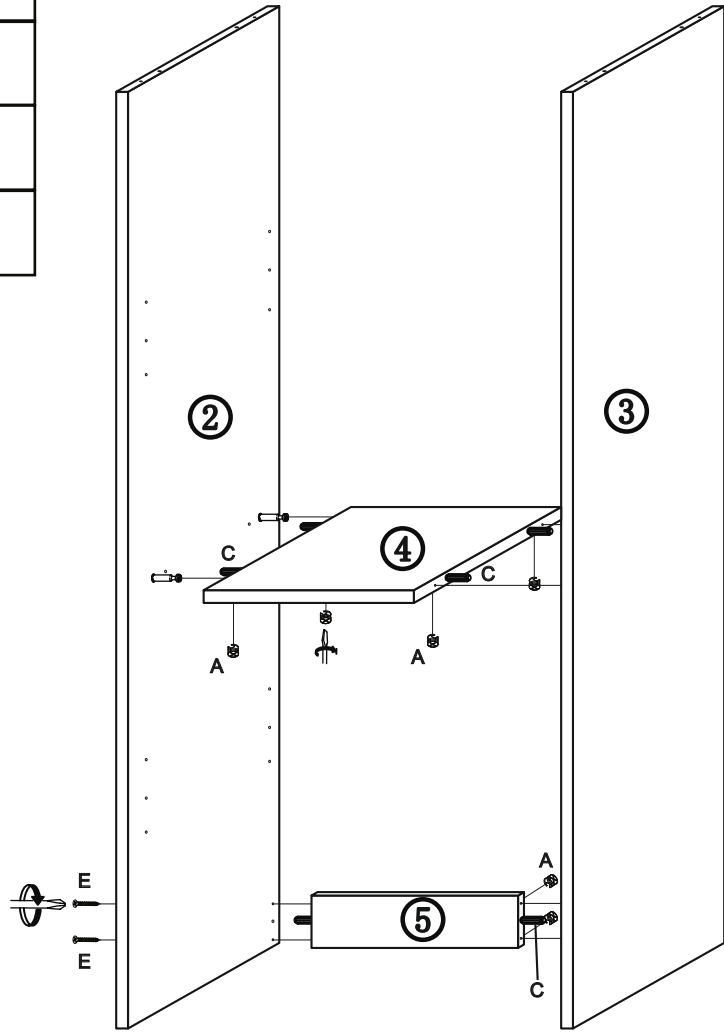

You will need:-

A		6PCS
C		6PCS
E		2PCS

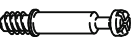

STEP 3

You will need:-

A		6PCS
I		1PC
K		2PCS

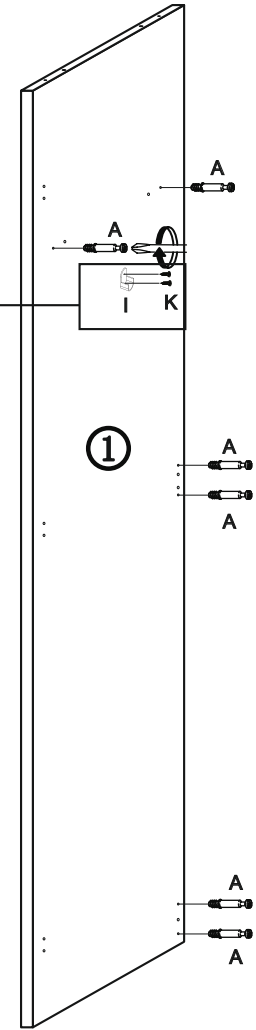
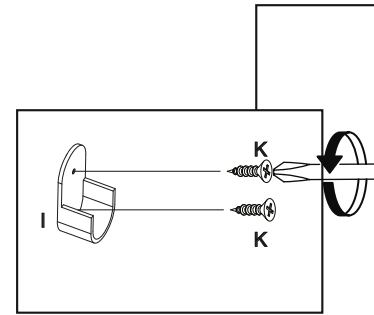

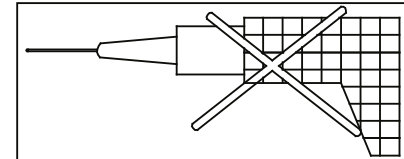

THE USE OF POWER TOOLS TO ASSEMBLE THIS PRODUCT WILL INVALIDATE ANY CLAIM AND MAY DAMAGE THIS PRODUCT MAKING IT UNSAFE



STEP 4

You will need:-

A		12PCS
C		10PCS

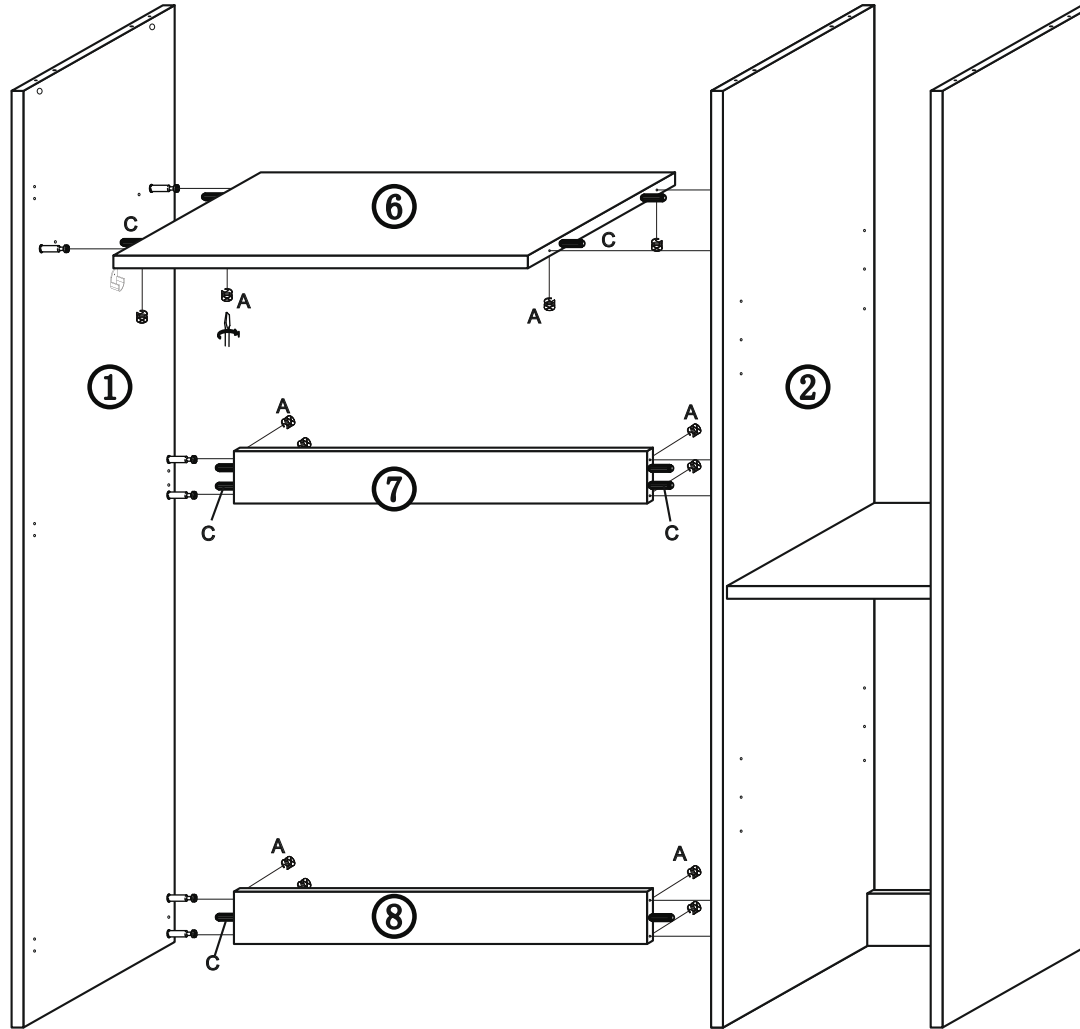

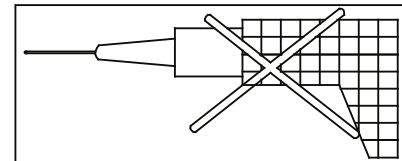

THE USE OF POWER TOOLS TO ASSEMBLE THIS PRODUCT WILL INVALIDATE ANY CLAIM AND MAY DAMAGE THIS PRODUCT MAKING IT UNSAFE



STEP 5

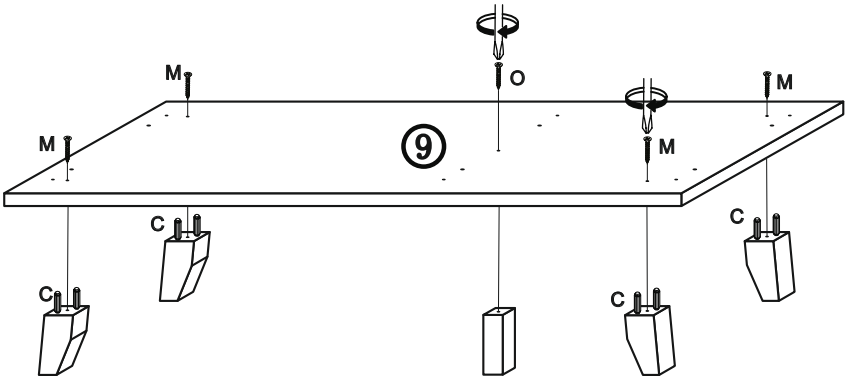

You will need:-

C		8PCS
M		4PCS
O		1PC



STEP 6

You will need:-

C		6PCS
E		6PCS

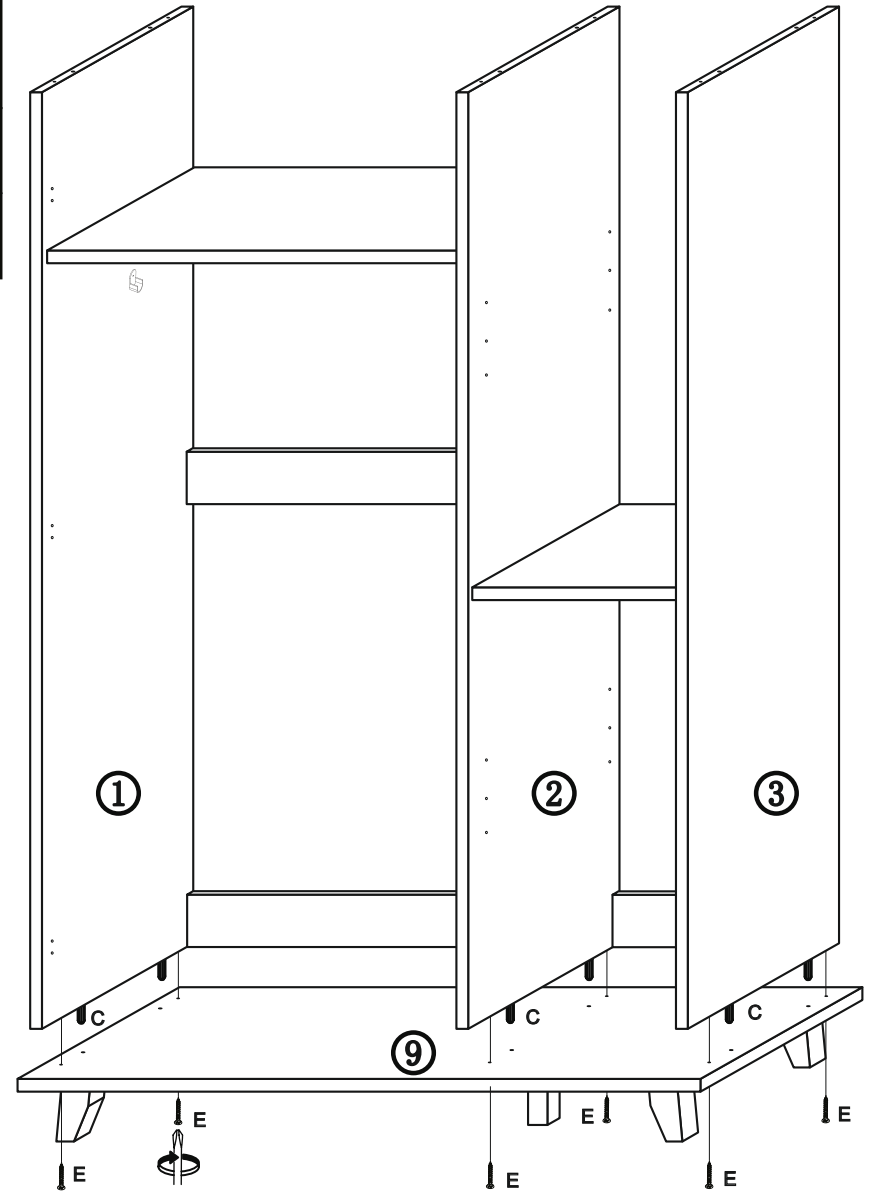

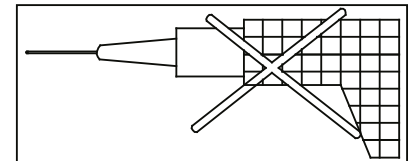

THE USE OF POWER TOOLS TO ASSEMBLE THIS PRODUCT WILL INVALIDATE ANY CLAIM AND MAY DAMAGE THIS PRODUCT MAKING IT UNSAFE



STEP 7

You will need:-

C		6PCS
E		6PCS

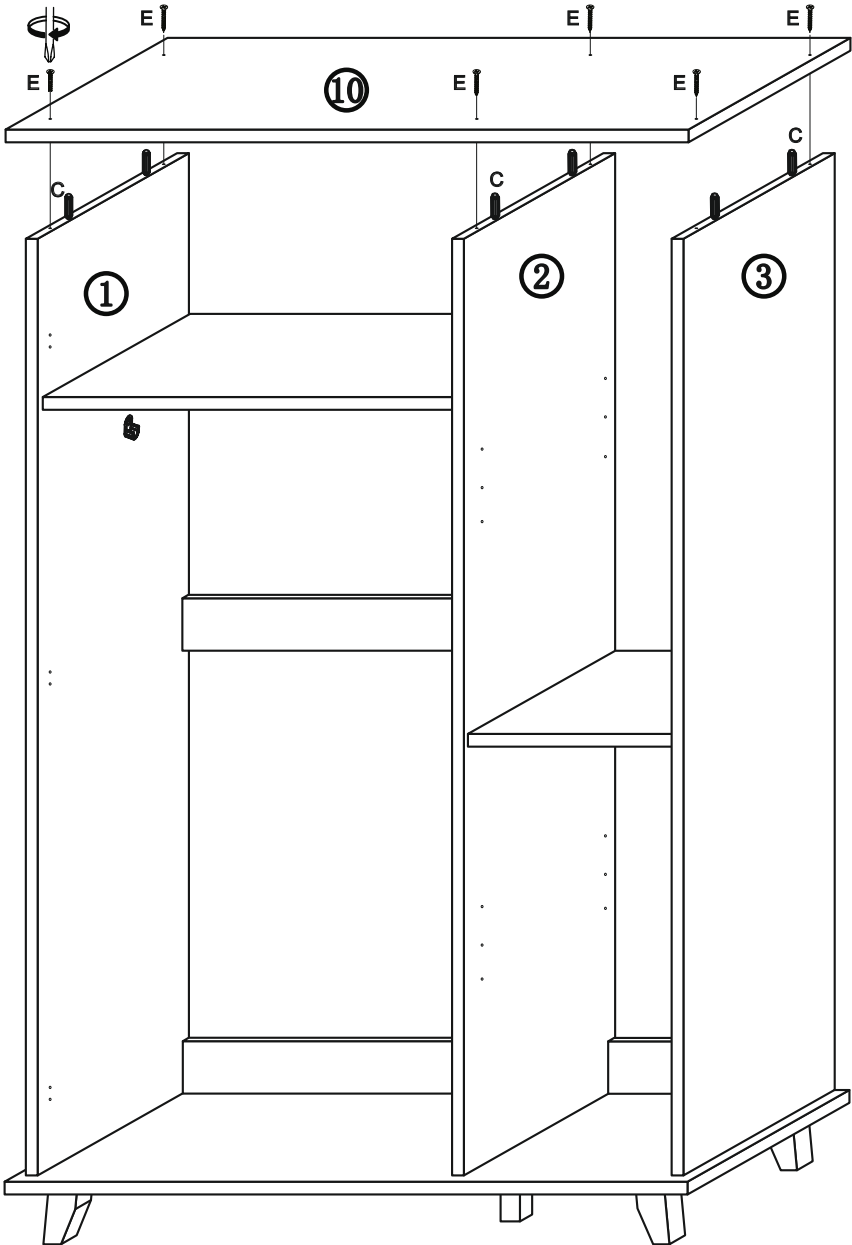

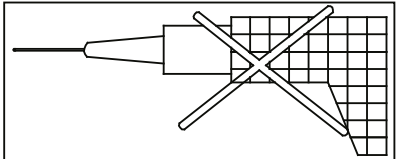

THE USE OF POWER TOOLS TO ASSEMBLE THIS PRODUCT WILL INVALIDATE ANY CLAIM AND MAY DAMAGE THIS PRODUCT MAKING IT UNSAFE



STEP 8

You will need:-

F		42PCS
G		5PCS

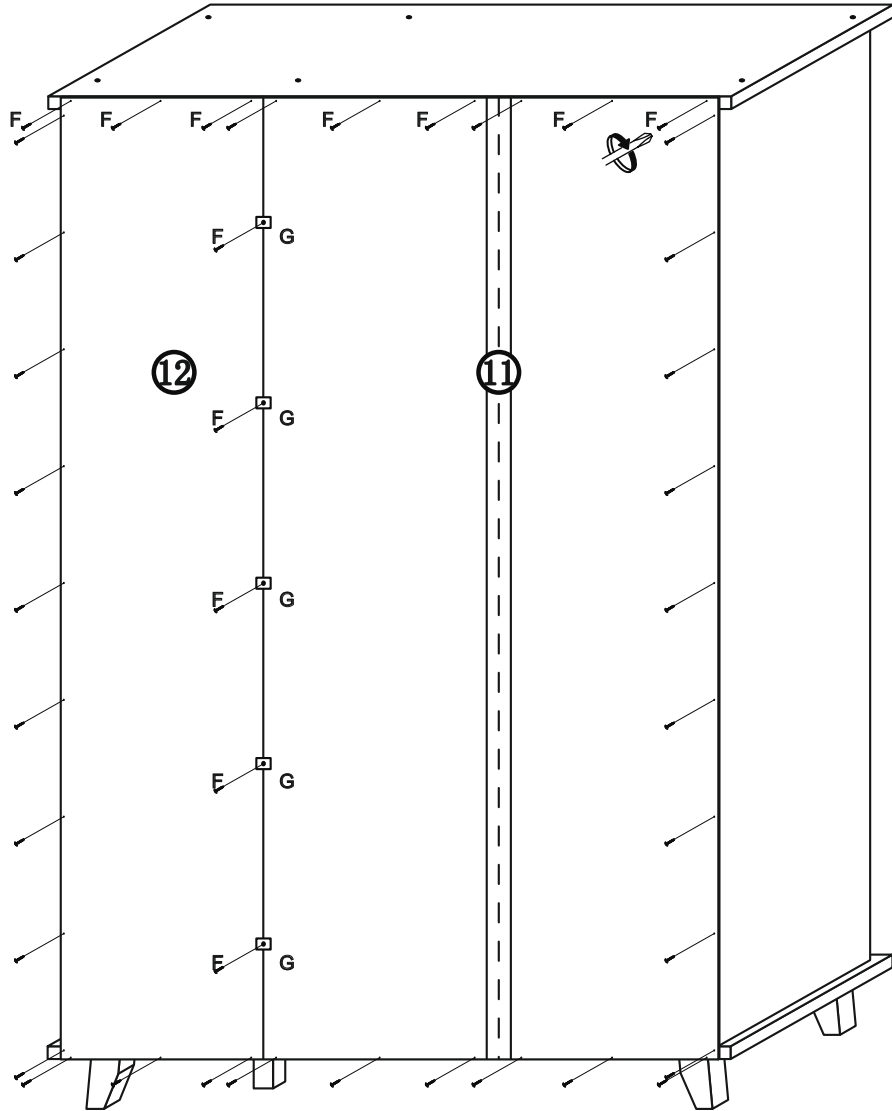

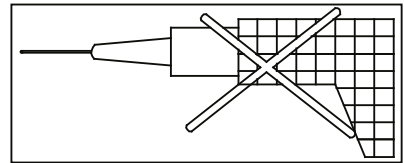

THE USE OF POWER TOOLS TO ASSEMBLE THIS PRODUCT WILL INVALIDATE ANY CLAIM AND MAY DAMAGE THIS PRODUCT MAKING IT UNSAFE



STEP 9

You will need:-

H		8PCS
J		1PC

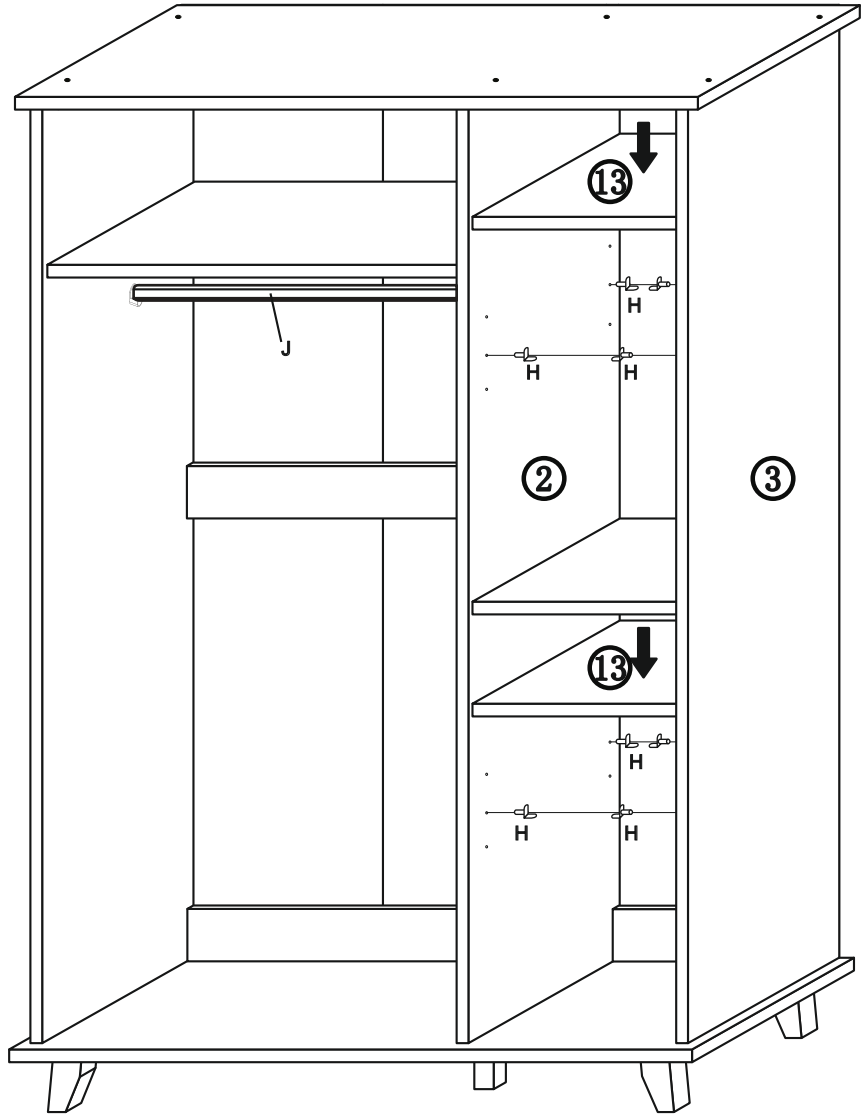



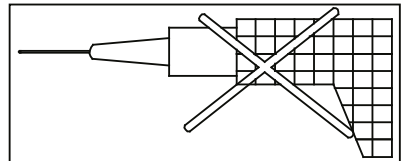

THE USE OF POWER TOOLS TO ASSEMBLE THIS PRODUCT WILL INVALIDATE ANY CLAIM AND MAY DAMAGE THIS PRODUCT MAKING IT UNSAFE



STEP 10

You will need:-

B		3PCS
K		36PCS
L		6PCS
N		3PCS

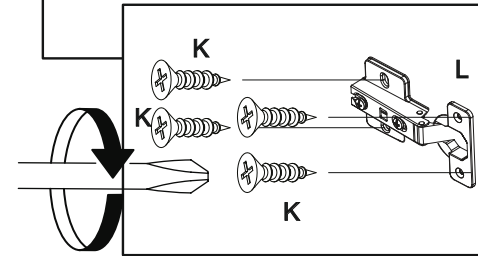
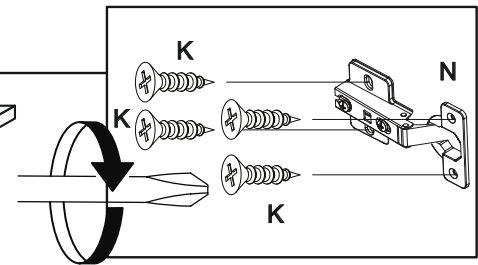
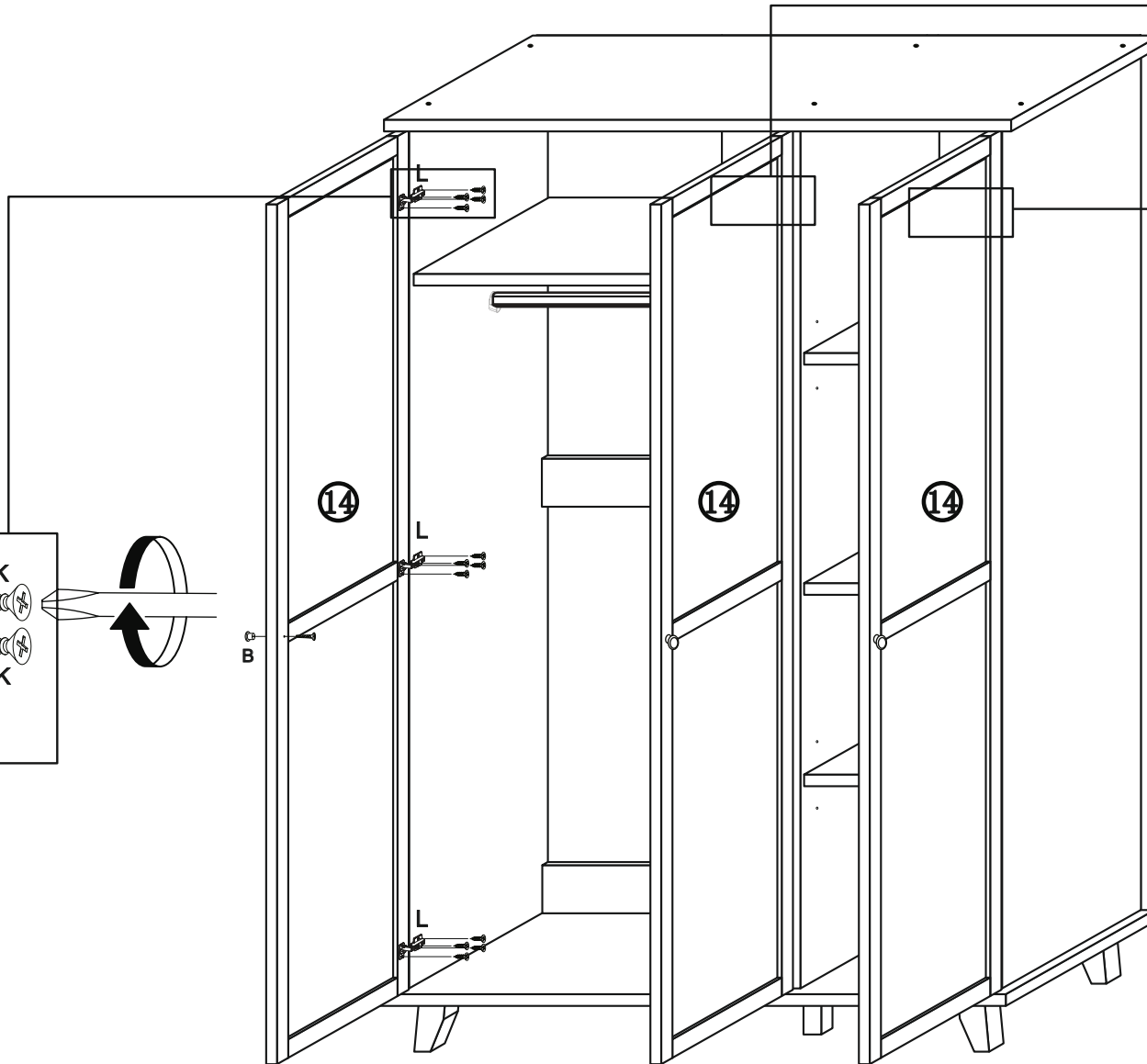
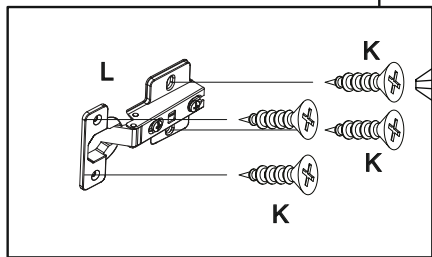

THE USE OF POWER TOOLS TO ASSEMBLE THIS PRODUCT WILL INVALIDATE ANY CLAIM AND MAY DAMAGE THIS PRODUCT MAKING IT UNSAFE

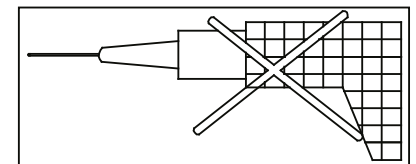

STEP 11

You will need:-

D



2PCS

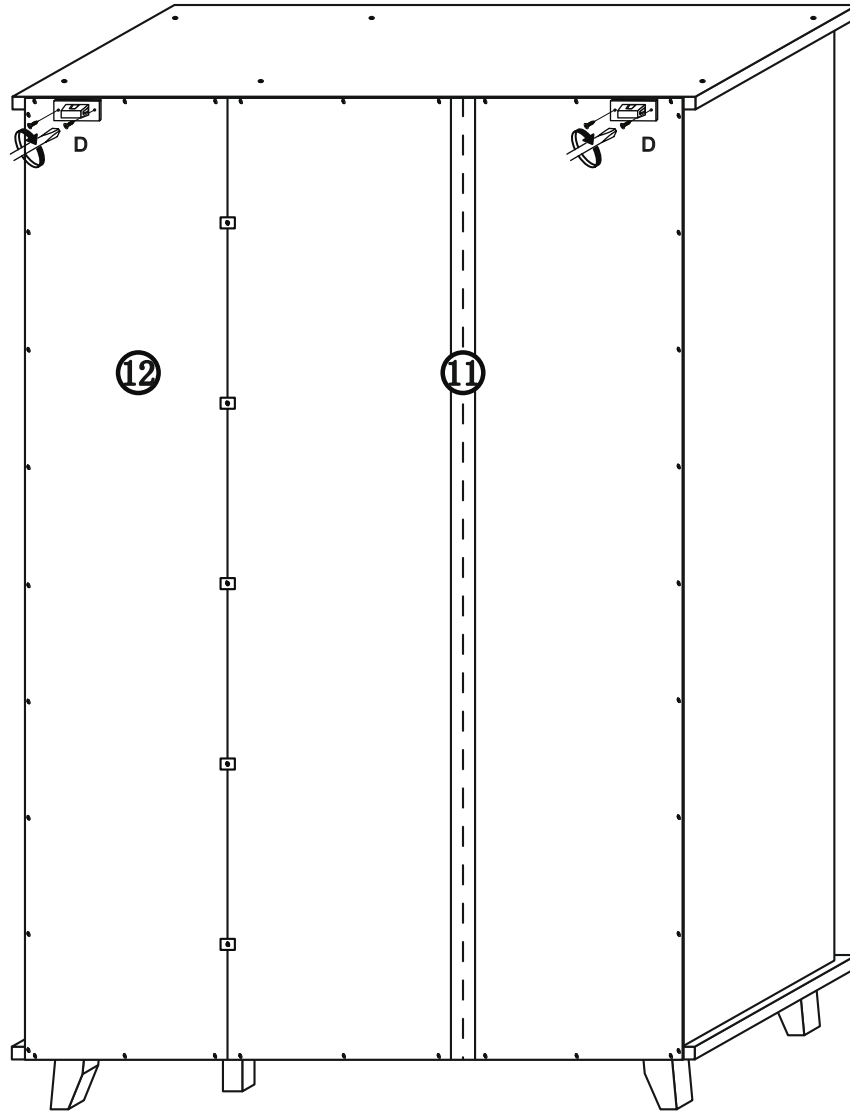

THE USE OF POWER TOOLS TO ASSEMBLE THIS PRODUCT WILL INVALIDATE ANY CLAIM AND MAY DAMAGE THIS PRODUCT MAKING IT UNSAFE

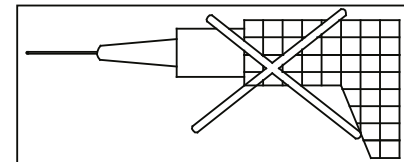

STEP 12

You will need:-

D



2PCS

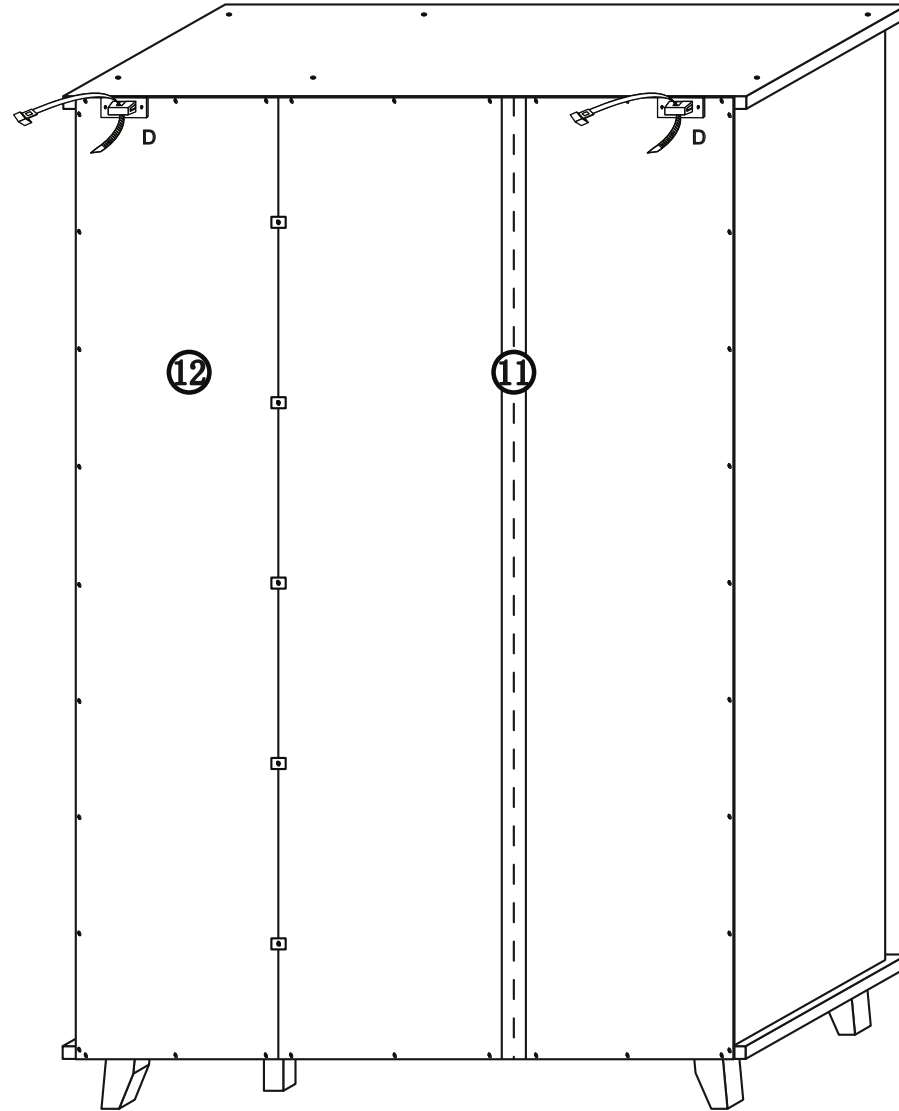

THE USE OF POWER TOOLS TO ASSEMBLE THIS PRODUCT WILL INVALIDATE ANY CLAIM AND MAY DAMAGE THIS PRODUCT MAKING IT UNSAFE

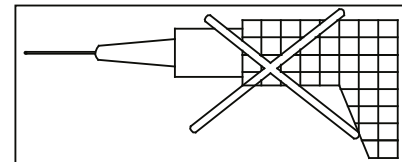

STEP 13

You will need:-

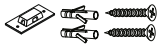
D  **2PCS**

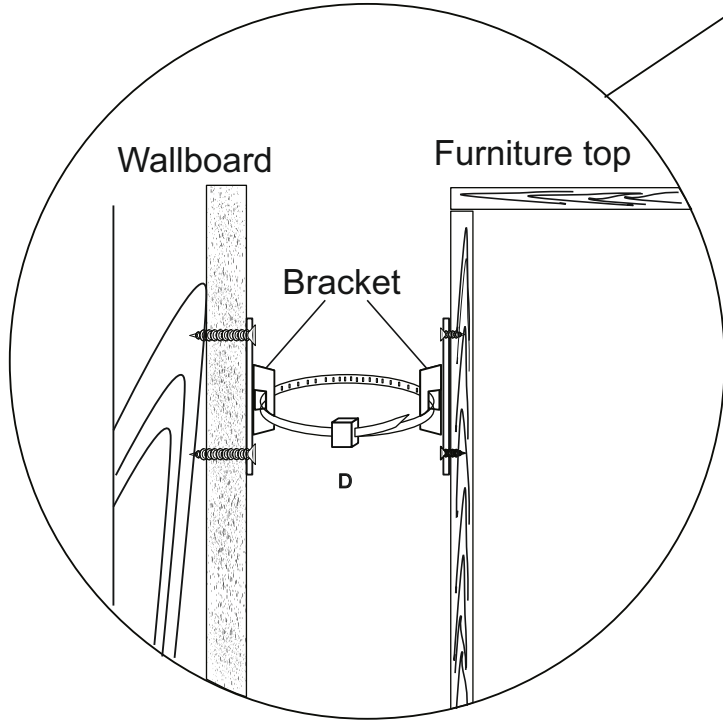

Note: Please ensure a suitable wall fixing is used when attaching the unit to the wall.

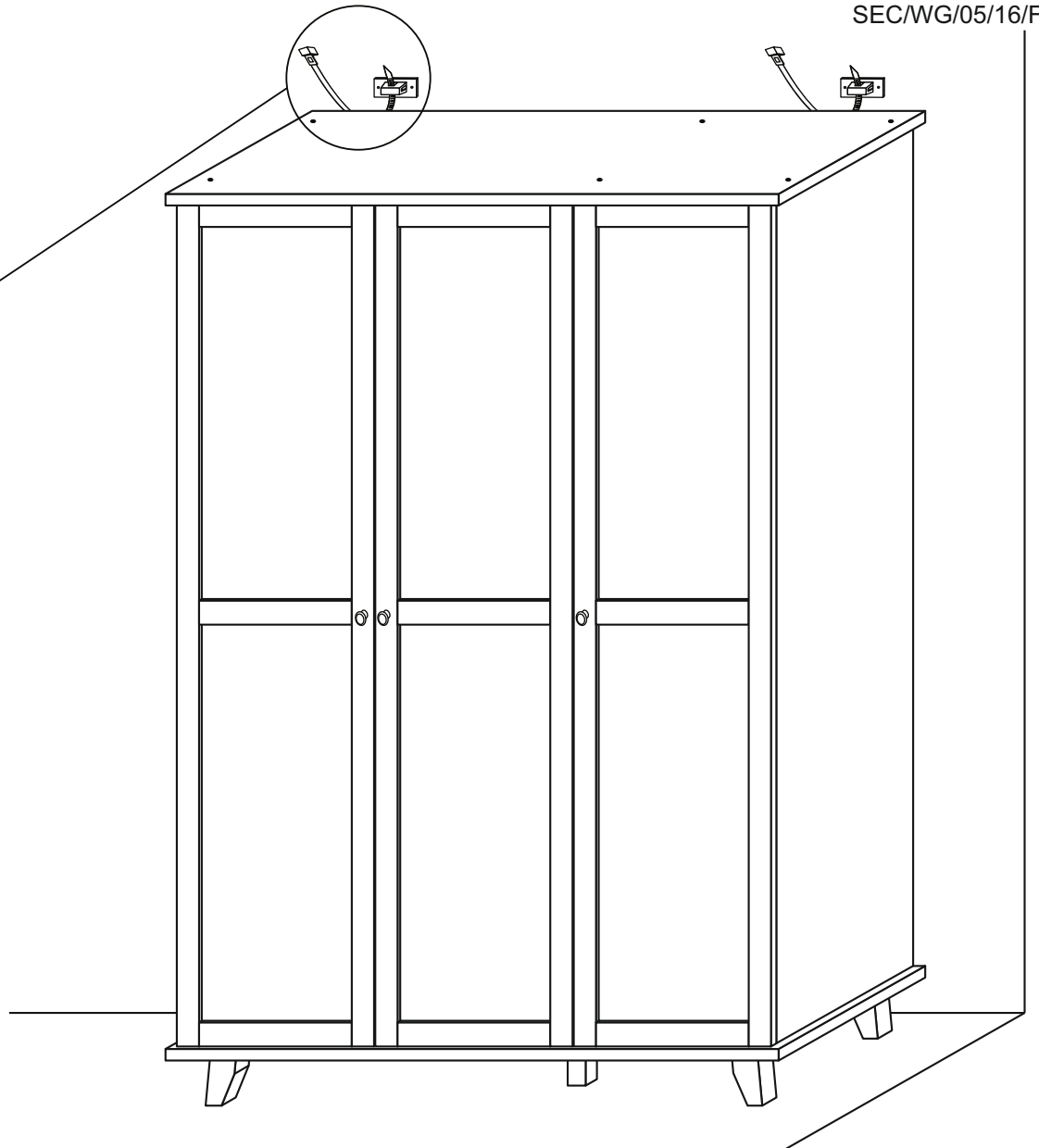

THE USE OF POWER TOOLS TO ASSEMBLE THIS PRODUCT WILL INVALIDATE ANY CLAIM AND MAY DAMAGE THIS PRODUCT MAKING IT UNSAFE

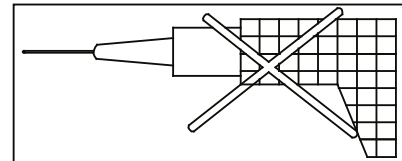

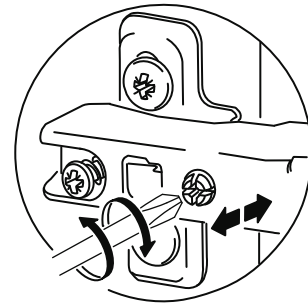
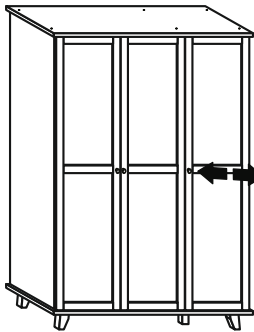
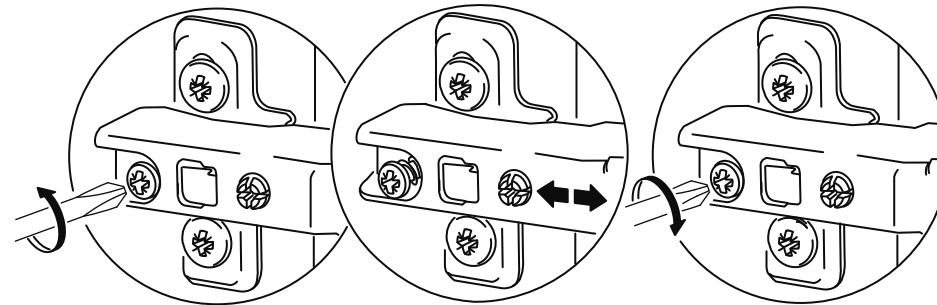
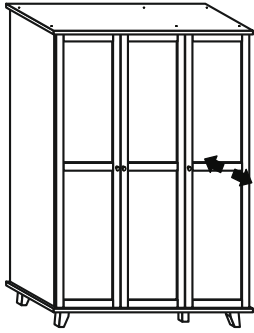
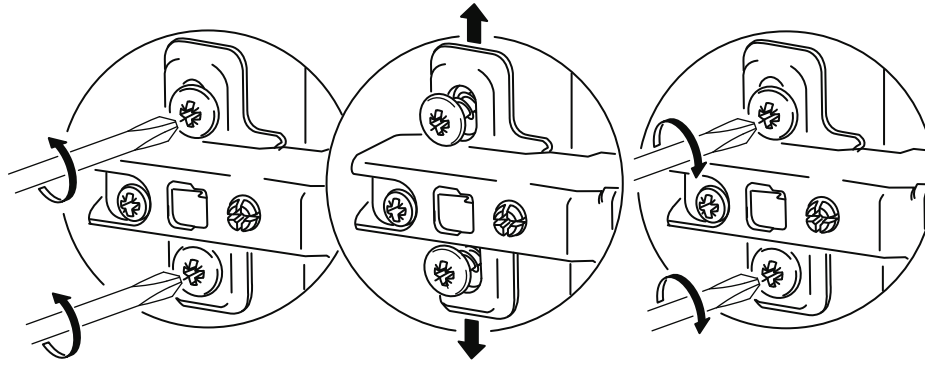
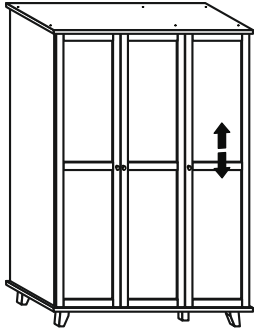

THE USE OF POWER TOOLS TO ASSEMBLE THIS PRODUCT WILL INVALIDATE ANY CLAIM AND MAY DAMAGE THIS PRODUCT MAKING IT UNSAFE

