



MODEL/MODELO/MODÈLE: SOC056_168B

ASSEMBLY INSTRUCTIONS
INSTRUCCIONES DE ENSAMBLAJE
INSTRUCTIONS D'ASSEMBLAGE



ATTENTION

**DO NOT RETURN
TO THE STORE**

Contact
MD Sports
Customer Service

* For additional resources and Frequently
Asked Questions, please visit us at
themdsports.com

ATENCIÓN

**NO DEVOLVERLO
A LA TIENDA**

Contacto
MD Sports
Servicio al Cliente

* Por mayor información y Preguntas
Frecuentes, favor visitarnos en
themdsports.com

ATTENTION

**NE PAS RAPPORTER
EN MAGASIN**

Contactez
MD Sports
Service Clientèle

* Pour toute information complémentaire
ou réponse aux questions fréquentes
veuillez vous rendre sur
themdsports.com

LIMITED 90 DAYS WARRANTY

This product is covered by a limited warranty that is effective for 90 days from the date of purchase. If, during the limited warranty period, a part is found to be defective or breaks, we will offer replacement parts at no cost to you, the customer. The only exceptions to the warranty include mainframes, table tops, playing surfaces, batteries or tools.

The above warranty will not apply in cases of damages due to improper usage, alteration, misuse, abuse, accidental damage or neglect.

This Limited Warranty gives you specific legal rights and you may also have other rights which vary from one State (province) to another.

A PURCHASE RECEIPT (or other proof of purchase) will be required before any warranty service is initiated. For all requests for warranty service, please feel free to contact our Consumer Service Department at:

WEBSITE: www.themdsports.com

Please be aware of your product's Limited Warranty for the return/refund policy from the store. We, at Medal Sports, cannot handle the product which is out of product's limited warranty since we only provide available parts. Thank you!

PLEASE CONTACT US BEFORE RETURNING THE PRODUCT TO THE STORE.

GARANTÍA LIMITA DE 90 DIAS

Este producto está cubierto por una garantía efectiva de 90 días a partir de la fecha de su compra. Durante el período límite de la garantía, si una parte defectuosa o quebrada es encontrada, nosotros ofreceremos una reparación o un reemplazo de la partes sin ningún costo para ud, nuestro cliente. Las únicas excepciones de la garantía incluyen unidad principales, tableros de mesa, superficies, pilas o herramientas.

La susodicha garantía no se aplicará en los casos de daños y perjuicios debido al uso impropio, la alteración, el mal uso, el abuso, el daño accidental o la negligencia.

Esta garantía limitada le da a usted derechos legales específicos, usted también puede tener otros derechos que varían de un estado (provincia) a otro.

EL RECIBO DE LA COMPRA (U otra prueba de compra) sería requerida antes que cualquier servicio de garantía fuera iniciada. Para todo pedido por servicio de garantía, por favor siéntase libre de ponerse en contacto con nuestro Departamento de Servicio de Consumidor en:

WEBSITE: www.themdsports.com

Por favor tenga atención sobre el Límite de Garantía de su producto de la política de vuelta/reembolsa desde la tienda, Nosotros, Medal Sports, no podemos manejar el producto que está fuera del límite de garantía ya que proporcionamos solamente partes disponibles. ¡Gracias!

POR FAVOR PÓNGASE EN CONTACTO CON NOSOTROS ANTES DE DEVOLVER EL PRODUCTO A LA TIENDA.

GARANTIE LIMITEE DE 90 JOURS

Ce produit est couvert par une garantie limitée valable 90 jours à compter de la date d'achat. Si pendant cette période une pièce est jugée défectueuse ou se casse, nous la remplacerons gratuitement. Les seules exceptions à la garantie comprennent les armatures principales, les dessus de table, les surfaces de jeu, les piles ou les outils.

La garantie ci-dessus ne s'applique pas en cas de dommages occasionnés par une mauvaise utilisation, une altération du produit, de mauvais traitements, des dommages accidentels ou des négligences.

Cette garantie limitée vous accorde des droits légaux spécifiques ainsi que d'autres droits variant d'un état (province) à un autre.

UNE FACTURE D'ACHAT (ou toute autre preuve d'achat) sera exigée avant toute intervention sous garantie. Pour toute demande d'intervention sous garantie, veuillez contacter notre Service à la Clientèle au:

SITE WEB: www.themdsports.com

Comprenez notre garantie produit limitée en ce qui concerne notre politique de retour/remboursement depuis votre magasin. Ici à Medal Store, nous ne pouvons prendre un compte un produit qui n'est plus sous garantie puisque nous ne pouvons que fournir les pièces disponibles. Remerciements!

VEUILLEZ NOUS CONTACTER AVANT DE RETOURNER LE PRODUIT EN MAGASIN.

STAPLE YOUR RECEIPT HERE**NOTICE!**

- 1 - Please leave your name, address, phone number, model number, parts needed on the answering machine if there is no attendant. Failure to do so will result in a delay in shipping parts to you.
- 2 - Please review the replacement parts list and make sure that you have all of your parts before beginning assembly. For questions that may arise or for missing/damaged parts, please contact us.
- 3 - Since you build all tables upside down, please inspect tabletops or playing surfaces right away before putting together, all damaged table tops/playing surfaces need to be returned to the store. Please contact the retailer for their return policy.

GRAPA SU RECIBO AQU**¡AVISO!**

- 1 - Por favor deje su nombre, dirección, número telefónico, número de modelo, partes necesarios a la máquina contestadora si no fuera atendido. El fracaso de hacer así le causará un retraso del envío de partes.
- 2 - Por favor revise la lista de piezas de repuesto y asegúrese de que tiene todas las piezas antes de comenzar el montaje. Para preguntas o para piezas que no se hayan incluidos/dañadas, por favor pongase en contacto con nosotros.
- 3 - Ya que usted construye todas las mesas al revés, por favor inspeccione las partes superiores de mesa o superficies de juego enseguida antes de poner juntos, que todo tableros de mesa/superficies dañado tiene que ser devuelto a la tienda. Por favor comuníquese con el minorista por su política de devolución.

AGRAFEZ VOTRE REÇU ICI**AVIS!**

- 1 - Veuillez laisser votre nom, adresse, n° de téléphone, n° de modèle et pièces demandées sur notre répondeur si personne ne répond. Si vous ne le faites pas, il en résultera des délais dans l'acheminement des pièces jusqu'à votre domicile.
- 2 - Veuillez consulter la liste des pièces et assurez-vous que vous avez toutes les pièces avant de commencer l'assemblage. Veuillez nous contacter pour toute question ou toute pièce manquante/endommagée.
- 3 - Puisque toutes les tables sont assemblées la tête en bas, veuillez inspecter les dessus de tables ou les surfaces de jeu avant de les assembler. Les dessus de tables ou les surfaces de jeu endommagés doivent être retournés au magasin. Veuillez contacter votre vendeur pour information sur le retour des pièces.

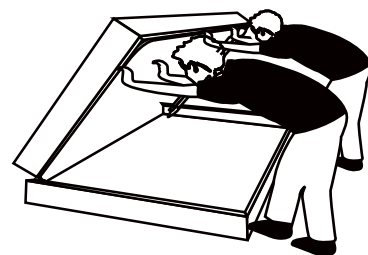
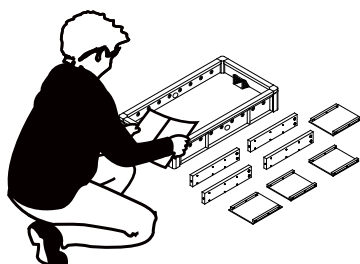

TOOLS REQUIRED

Phillips Screwdriver-**Not Included**
Standard (Flat Head Screwdriver)-**Not Included**
Allen Key-**Included**

**CAUTION!**

Electric screwdrivers may be helpful during assembly; however, please set a low torque and use extreme caution.

ASSEMBLY TIPS

- 1 - Please read the instructions carefully, and follow all assembly, operation, and safety instructions properly in order to avoid damage or injury. For the assembly, at least two adults are required.
- 2 - Some figures or drawings may not look exactly like your product. Please read and understand the text before beginning each assembly step.

IMPORTANT NOTICE!

- 1 - This product is intended for INDOOR use only.
- 2 - Please do not sit, climb, or lean on the product.
- 3 - Please do not drag the product when moving it in order to avoid damaging the legs.
- 4 - Please only use spray furniture polish to clean the exterior surfaces of the product.
- 5 - This is not a child's toy, adult supervision is required for children playing this game.

⚠ WARNING:
Adult Assembly Required.

⚠ WARNING:
CHOKING HAZARD - This item contains small parts. Not suitable for children under 3 years.

HERRAMIENTAS NECESARIAS

Destornillador Phillips-**No incluido**
Destornillador de Cabeza Plana-**No incluido**
Llave Allen-**Incluido**

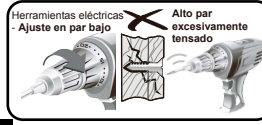
**¡PRECAUCIÓN!**

Los destornilladores eléctricos pueden ser de gran ayuda durante el ensamblado; sin embargo, debe ajustar el par de giro bajo y ser extremadamente precavido.

CONSEJOS PARA EL ENSAMBLADO

- 1 - Lea las instrucciones detenidamente y siga todas las instrucciones de ensamblaje, funcionamiento y seguridad correctamente para evitar daños o lesiones. Se necesitan por lo menos dos adultos para realizar el ensamblaje.
- 2 - Algunas figuras o dibujos podrían parecer diferentes a su producto. Lea y entienda el texto antes de iniciar cada paso del ensamblaje.

¡AVISO IMPORTANTE!

- 1 - Este producto está destinado únicamente para el uso INTERIOR.
- 2 - NO se sienta, suba o apoye sobre el producto.
- 3 - NO arrastre el producto cuando lo mueva para evitar el daño a las patas.
- 4 - Solo use la cera espray de muebles para limpiar las superficies exteriores del producto.
- 5 - Este producto no es un juguete de niños; la supervisión de adultos es necesaria cuando los niños hagan uso este juego.

⚠ ADVERTENCIA:
El ensamblaje debe ser realizado por un adulto.

⚠ ADVERTENCIA:
PELIGRO DE ASFIXIA - Este artículo contiene piezas pequeñas. No apto para menores de 3 años.

OUTILS REQUIS

Tournevis cruciforme-**Non inclus**
Tournevis standard (Tête plate)-**Non inclus**
Clé hexagonale-**incluse**

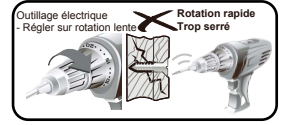
**ATTENTION!**

Un tournevis électrique peut être utile pour l'assemblage; utilisez cependant une vitesse de rotation lente et avec prudence.

CONSEILS POUR L'ASSEMBLAGE

1. Veuillez lire avec attention les instructions et suivre à la lettre les instructions de montage et de sécurité pour éviter dommages ou blessures. L'assemblage nécessite au minimum deux adultes.
2. Certaines images ou schémas peuvent différer sensiblement de votre produit. Veuillez lire et comprendre le texte avant de commencer l'assemblage.

NOTE IMPORTANTE!

- 1 - Ce produit est conçu pour une utilisation en intérieur uniquement.
- 2 - Veuillez ne pas vous asseoir, grimper ou vous appuyer sur la produit.
- 3 - Veuillez ne pas trainer ce produit quand vous le déplacez pour éviter d'endommager les pieds.
- 4 - Veuillez n'utiliser que du poli à meubles en aérosol pour nettoyer les surfaces extérieures du produit.
- 5 - Ceci n'est pas un jeu d'enfant et la surveillance d'adultes est requise pour les enfants jouant à ce jeu.

⚠ ATTENTION:
Présence d'adultes nécessaire.

⚠ ATTENTION:
RISQUE DE SUFFOCATION - Cet article contient de petites pièces. Ne convient pas à des enfants de moins de 3 ans.



Strong Adults Needed

Adultos fuertes necesarios

Adultes robustes nécessaires



No Children in Assembly Area

No tener niños en el area de ensamble

Pas d'enfants dans la zone d'assemblage



Keep away from pets

Mantener alejados a los animales domesticos del area de ensamble

Tenir les animaux de compagnie à distance











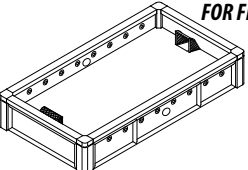
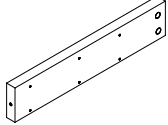
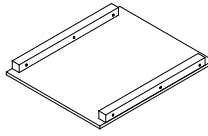
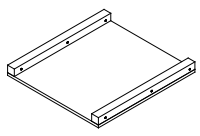
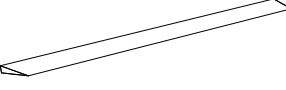
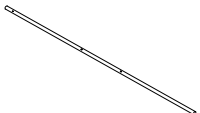
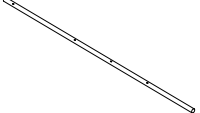
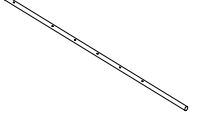







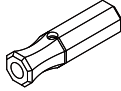

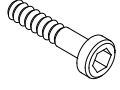

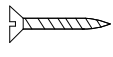
Do not use or keep product outdoors. For indoor use only. No wet/humid conditions.

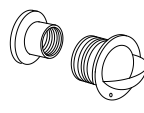
No usar o guardar el producto en el exterior. Solo para uso en interior. No utilizar ni guardar el producto en lugares húmedos o mojados

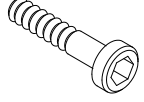
N'utilisez ni ne stockez ce produit en extérieur. Uniquement pour utilisation en intérieur. Pas de conditions humides





SOC056_168B PARTS LIST / LISTA DE PARTES / LISTE DES PIÈCES

<p>1 <i>FOR FIG. 3</i></p>  <p>x1</p>	<p>2 <i>FOR FIG. 1</i></p>  <p>x4</p>	<p>3 <i>FOR FIG. 1</i></p>  <p>x2</p>	<p>4 <i>FOR FIG. 2</i></p>  <p>x2</p>
Mainframe Unidad Principal Unité centrale	Leg Pierna Pied	End Leg Panel-A Panel de Pierna Final-A Panneau pied inférieur-A	End Leg Panel-B Panel de Pierna Final-B Panneau pied inférieur-B
<p>5 <i>FOR FIG. 4</i></p>  <p>x2</p>	<p>6 <i>FOR FIG. 5</i></p>  <p>x2</p>	<p>7 <i>FOR FIG. 5</i></p>  <p>x4</p>	<p>8 <i>FOR FIG. 5</i></p>  <p>x2</p>
Playfield Ramp Rampa de Cancha de Juego Rampe Terrain de Jeu	2-Hole Rod Barra de 2 Agujeros Tige à 2 trous	3-Hole Rod Barra de 3 Agujeros Tige à 3 trous	5-Hole Rod Barra de 5 Agujeros Tige à 5 trous
<p>9 <i>FOR FIG. 6</i></p>  <p>x13</p>	<p>10 <i>FOR FIG. 6</i></p>  <p>x13</p>	<p>11 <i>FOR FIG. 6</i></p>  <p>x13</p>	<p>12 <i>FOR FIG. 6</i></p>  <p>x13</p>
Player Head-Black Jugador Cabeza-Negro Tête Lecteur-Noir	Player Back-Black Jugador Trasero-Negro Lecteur Arrière-Noir	Player Head-Red Jugador Cabeza-Rojo Tête Lecteur-Rouge	Player Back-Red Jugador Trasero-Rojo Lecteur Arrière-Rouge
<p>13 <i>FOR FIG. 5</i></p>  <p>x16</p>	<p>14 <i>FOR FIG. 5</i></p>  <p>x16</p>	<p>15 <i>FOR FIG. 7</i></p>  <p>x8</p>	<p>16 <i>FOR FIG. 7</i></p>  <p>x8</p>
Rod Washer Arandela de Barra Rondelle de tige	Rod Bumper Bómpfer de Barra Amortisseur Tige	T5x15mm Bolt Cerrojo T5x15mm Boulon T5x15mm	Handle Mango Poignée
<p>17 <i>FOR FIG. 7</i></p>  <p>x8</p>	<p>18 <i>FOR FIG. 3</i></p>  <p>x8</p>	<p>19 <i>FOR FIG. 3</i></p>  <p>x8</p>	<p>20 <i>FOR FIG. 8</i></p>  <p>x2</p>
Rod End Cap Gorra de Barra Final Capuchon bout de tige	5/16"x3" Bolt Cerrojo 5/16"x3" Boulon 5/16"x3"	5/16" Washer Arandela 5/16" Rondelle 5/16"	Slide Scorer Resbaladilla de Marcador Marqueur à main
<p>21 <i>FOR FIG. 8</i></p>  <p>x4</p>	<p>22 <i>FOR FIG. 8</i></p>  <p>x2</p>	<p>23 <i>FOR FIG. 8</i></p>  <p>x2</p>	<p>24 <i>FOR FIG. 3</i></p>  <p>x4</p>
F4x1-1/2" Screw Tornillo F4x1-1/2" Vis F4x1-1/2"	F4x1/2" Screw Tornillo F4x1/2" Vis F4x1/2"	Plastic Ball Entry Rim Llanta de Entrada de Pelota Plástica Bord d'entrée du ballon plastique	Leg Leveler Nivelador de Pierna Niveleur de Pied
<p>25 <i>FOR FIG. 1, 2</i></p>  <p>x24</p>	<p>26 <i>FOR FIG. 1, 2</i></p>  <p>x24</p>	<p>27</p>  <p>x1</p>	<p>28</p>  <p>x1</p>
1/4"x1-1/2" Bolt Cerrojo 1/4"x1-1/2" Boulon 1/4"x1-1/2"	1/4" Washer 1/4" Washer 1/4" Washer	5mm Allen Key 5mm Llave Allen 5mm Clé Hexagonale	4mm Allen Key 4mm Llave Allen 4mm Clé Hexagonale

SOC056_168B PARTS LIST / LISTA DE PARTES / LISTE DES PIÈCES

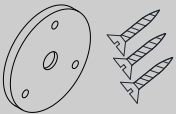
29	FOR FIG. 9
	
x2	
Soccer ball	Bola de Fútbol
	Ballon de Foot

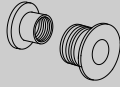
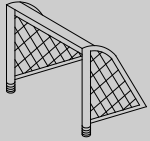
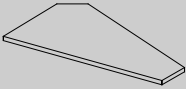
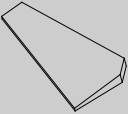
SOC056_168B PRE-INSTALLED PARTS / PIEZAS PREINSTALADAS / PIÈCES PRÉINSTALLÉES

P1	FOR FIG. 1	P2	FOR FIG. 1	P3	FOR FIG. 4	P4	FOR FIG. 4
							
x4		x24		x16		x2	
Square Nut with Screws	Tuerca Cuadrada con Tornillos	Écrou carré avec vis	M6 T-Nut	T - Tuerca M6	T - Boulon M6	Plastic Rod Bushing	Cojinete de Barra Plástica
		Manchon de la tige plastique	Goal Box	Caja de Gol	Goal avec câble		
P5	FOR FIG. 4	P6	FOR FIG. 4	P7	FOR FIG. 3		
							
x2		x2		x8			
Corner Bumper-A	Parachoques de rincón-A	Pare-choc de coin-A	Corner Bumper-B	Parachoques de rincón-B	Pare-choc de coin-B	M8 T-Nut	T - Tuerca M8
						T - Boulon M8	

ASSEMBLY INSTRUCTIONS:

1. Find a clean, level place to begin the assembly of your product.
2. Remove all the parts from the box and verify that you have all of the listed parts as shown on the parts list pages.
Carefully cut or tear the four corners of the box so that the bottom of the box can be used as your work surface.

INSTRUCCIONES DE ENSAMBLAJE:

1. Encuentre un lugar limpio y nivelado para comenzar el ensamblaje de su producto.
2. Retire todas las piezas de la caja y verifique que cuente con todas las piezas enumeradas en las páginas de la Lista de piezas.
Corte o rasgue cuidadosamente las cuatro esquinas de la caja de modo que el fondo de la caja pueda ser usado como su superficie de trabajo.

INSTRUCTIONS D'ASSEMBLAGE:

1. Trouvez un endroit propre et plat pour commencer à assembler votre produit.
2. Enlevez toutes les pièces de la boîte et assurez-vous que vous avez toutes les pièces listés sur la page de liste des pièces.
Coupez soigneusement les quatre coins de la boîte; le fond de la boîte peut être utilisé comme surface de travail.







- ②  X 4
- ③  X 2
- ②⑤  X 12
- ②⑥  X 12
- P1  X 4
- P2  X 24
- ②⑧  X 1

FIG. 1

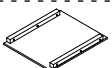



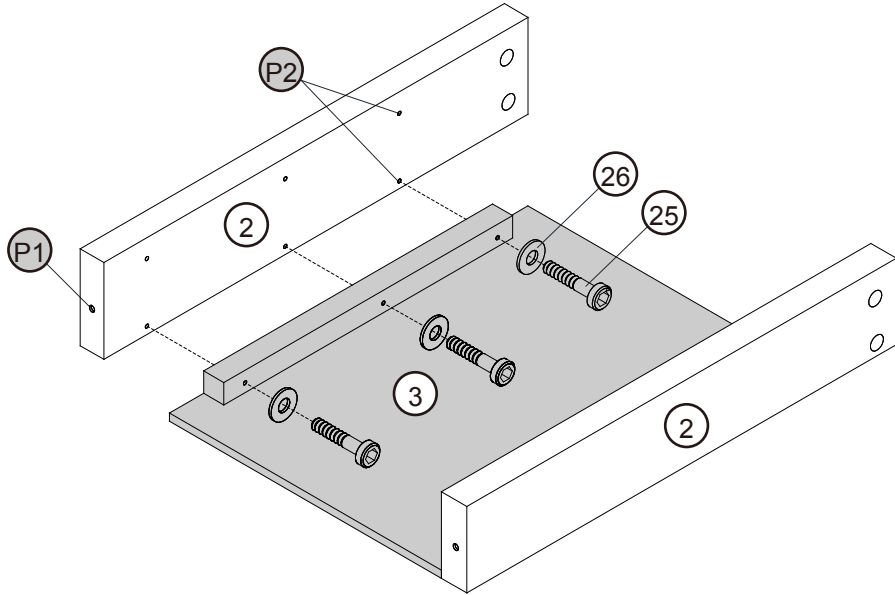

- ④  X 2
- ②⑤  X 12
- ②⑥  X 12
- ②⑧  X 1

FIG. 2



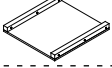



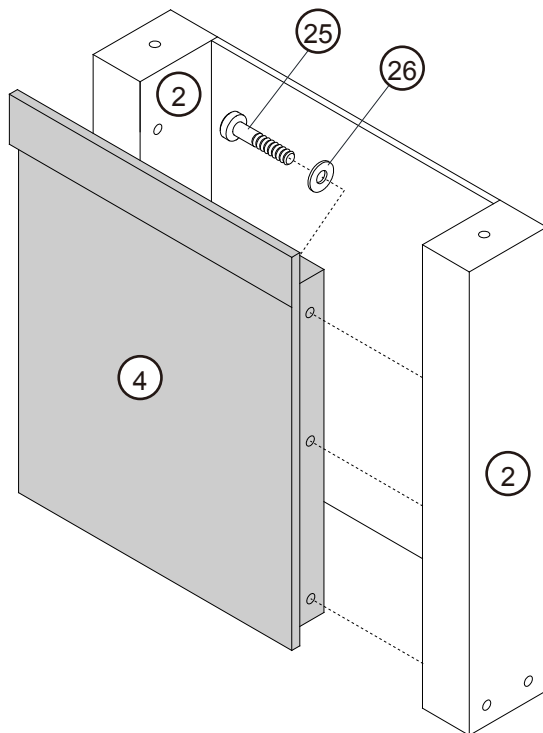

1		X 1
18		X 8
19		X 8
24		X 4
P7		X 8
27		X 1

FIG. 3

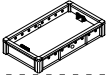

<p>HOLD BY THE TABLETOP / SOSTENER DE LA SUPERFICIE DE LA MESA / SOULEVER PAR LE DESSUS DE TABLE</p> 	<p>DO NOT HOLD THE TABLE BY THE LEGS / NO SOSTENER LA MESA POR LAS PATAS / NE PAS SOULEVER LA TABLE PAR LES PIEDS</p> 	<p>DO NOT LEAN THE TABLE ON ITS LEGS / NO INCLINAR LA MESA SOBRE LAS PATAS / NE FAITES PAS PENCHER LA TABLE SUR SES PIEDS</p> 
---	--	---

CAUTION: Two strong adults are recommended to turn over the table as shown.
 1. Lift the table off the ground.
 2. Turn the table over.
 3. Place all four feet on the ground at the same time.

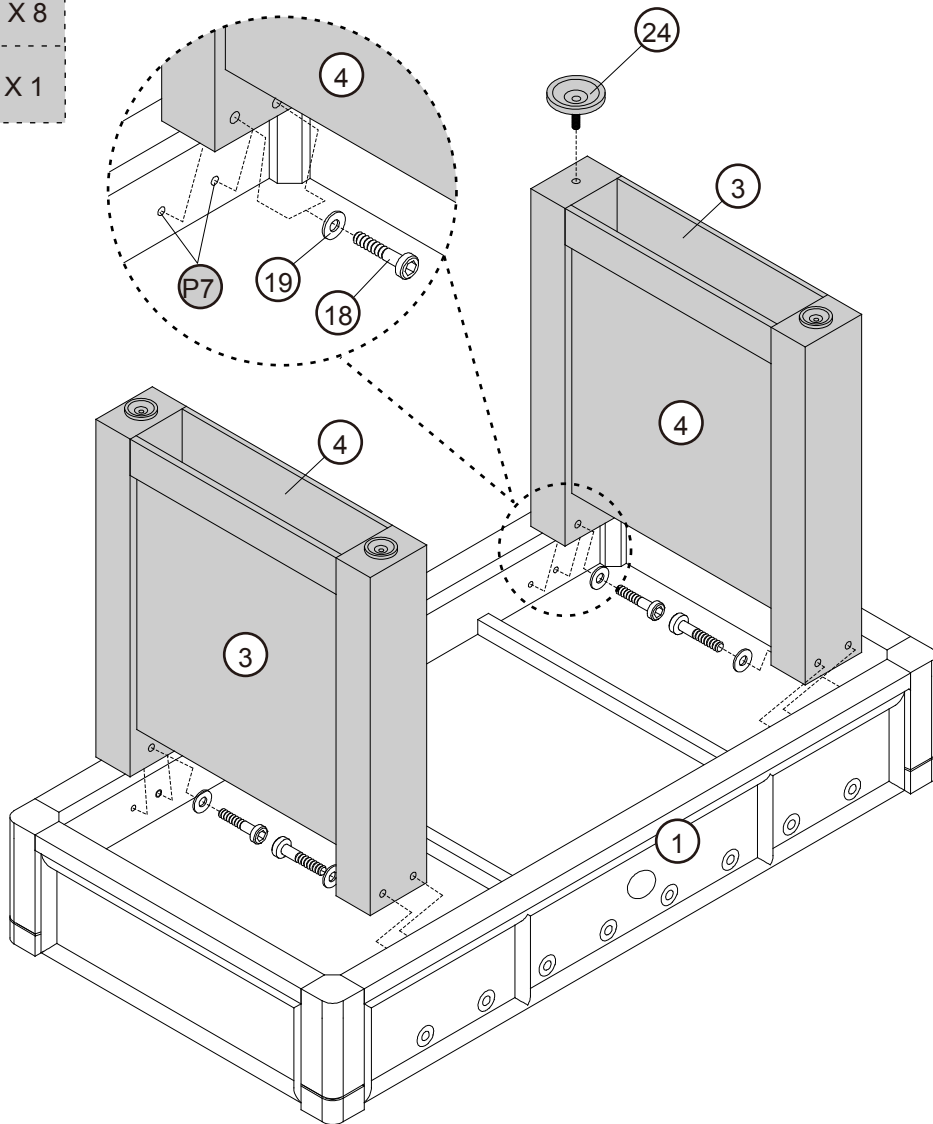
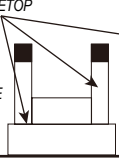
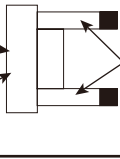
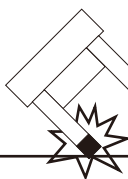
PRECAUCIÓN: Se recomienda la participación de dos adultos para invertir la mesa como se muestra.
 1. Levante la tabla del suelo.
 2. Inviértala.
 3. Coloque las cuatro patas en el suelo al mismo tiempo.

ATTENTION: La présence de deux adultes robustes est recommandée pour retourner la table comme sur Fig.
 1. Soulevez la table du sol.
 2. Retournez-la.
 3. Placez ses quatre pieds sur le sol simultanément.





(5)		X 2
(P3)		X 16
(P4)		X 2
(P5)		X 2
(P6)		X 2

FIG. 4





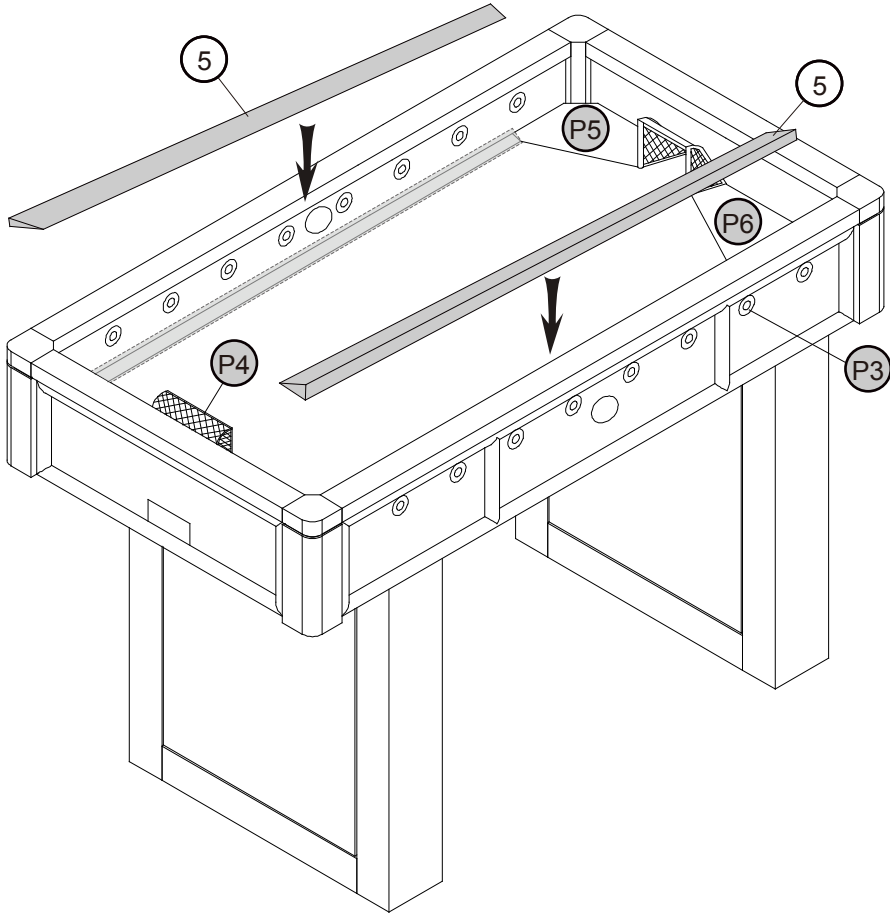
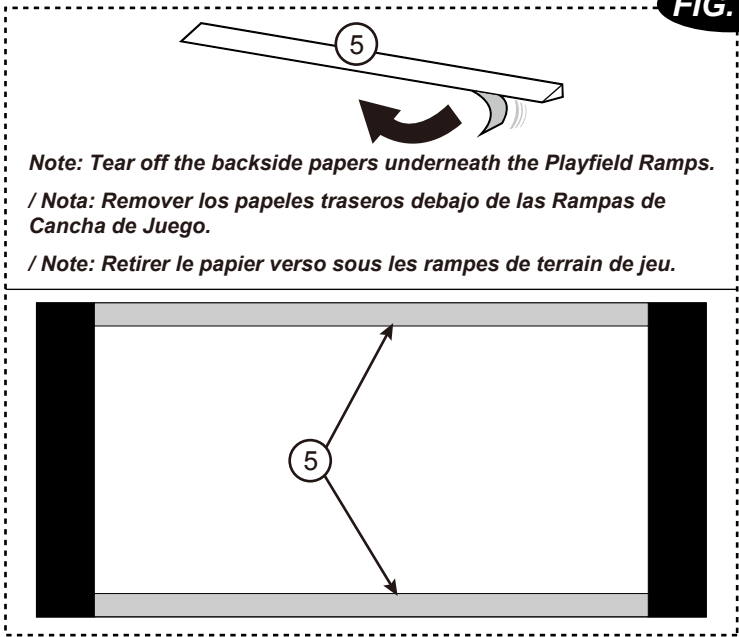

6		X 2
7		X 4
8		X 2
13		X 16
14		X 16

FIG. 5

Note: Hole at the end of Rod designates handle location. See Arrow Location Below.

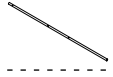
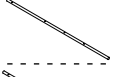
/ Nota: Agujero en el final de Barra se designa la posición de manija. Vea la Siguiete Posición de Flecha.

/ Note: L'orifice à l'extrémité d la Tige désigne l'emplacement de la poignée. Voir emplacement Flèche ci-dessous.

FIG. 5A

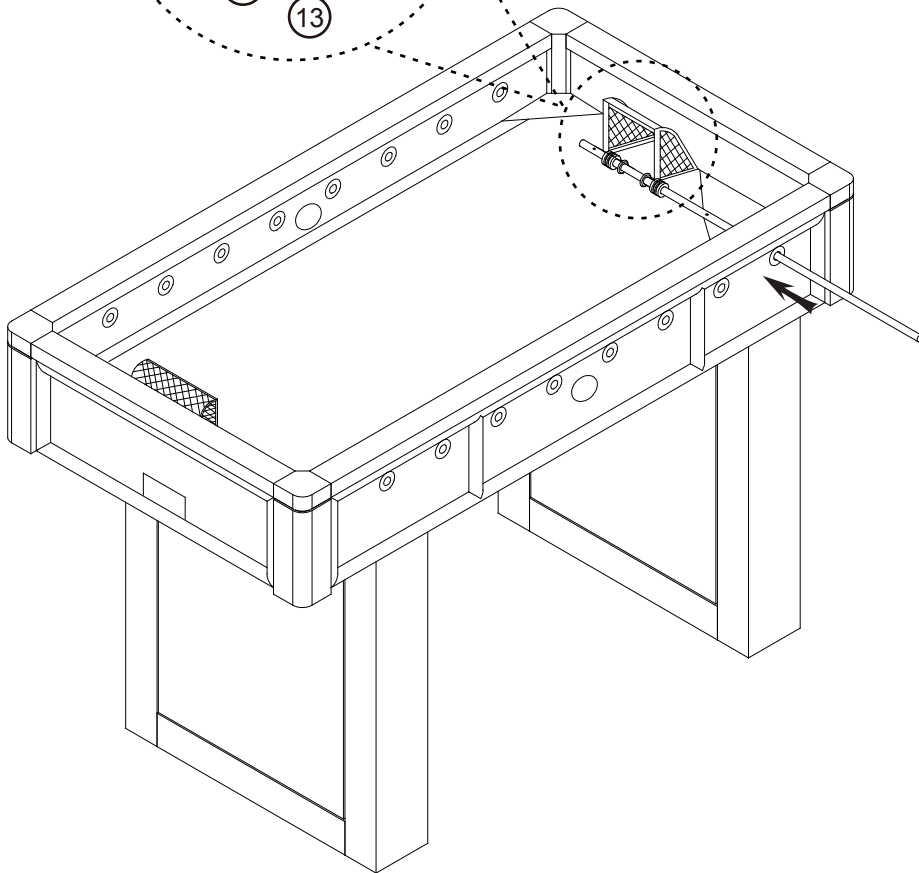
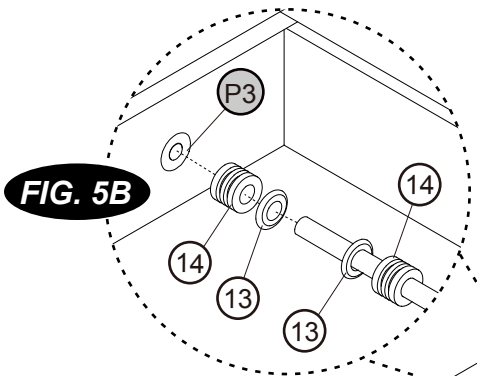
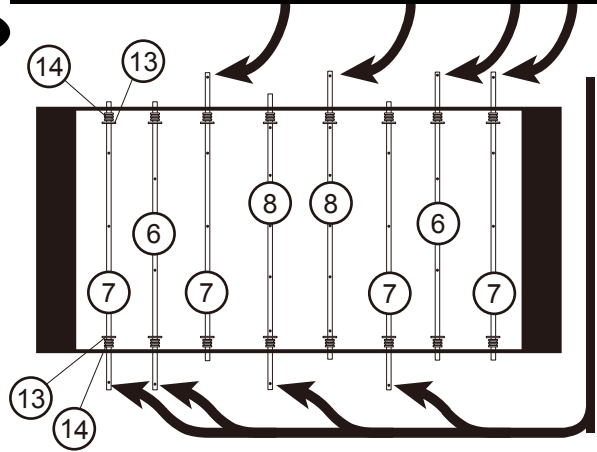





9		X 13	11		X 13
10		X 13	12		X 13

FIG. 6

Note: Make sure 1 Rod Bumper and 1 Rod Washer are at each end of the Player Rods before adding Players.

/ Nota: Haga seguro que 1 Bómpor de Barra y 1 Arandela de Barra están en cada final de las Barras de Jugador antes de agregar Jugadores.

/ Note: Assurez-vous qu'il y a bien un amortisseur et une rondelle à chaque extrémité des tiges joueurs avant d'ajouter les joueurs.

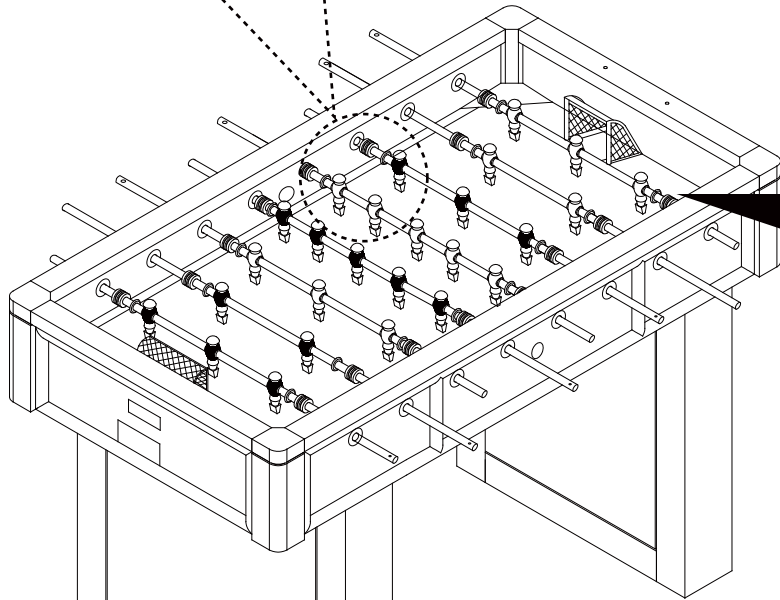
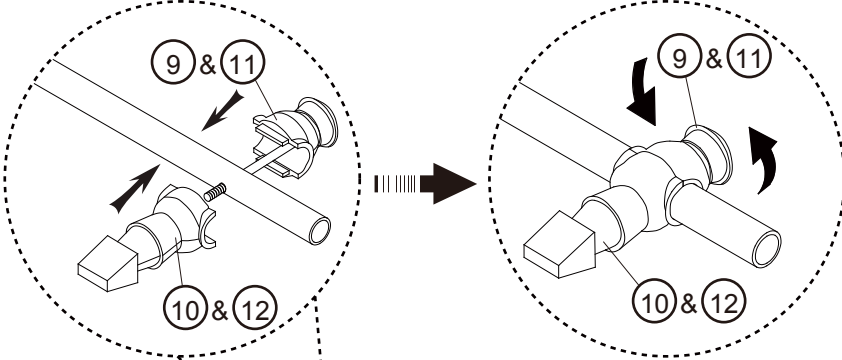
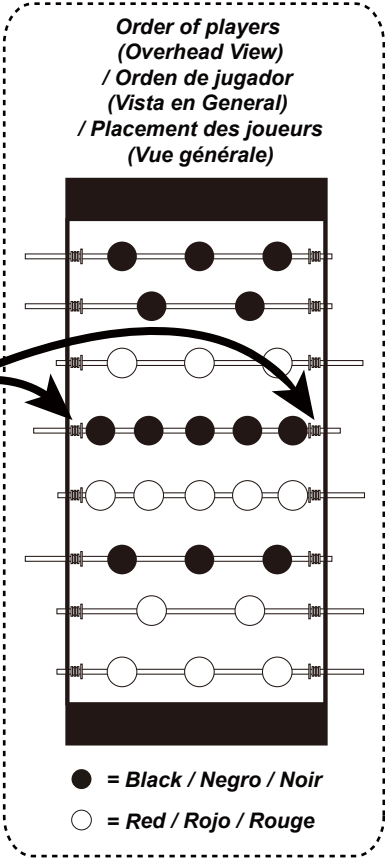

Note: The goalie should be at the left side of each player.

/ Nota: El portero debería estar en la izquierda de cada jugador.

/ Note: Le gardien de but doit être à la gauche de chaque joueur.

Note: Players of the same team color should have Handles (#16) on the same side, and each team's players should be facing their opponent.

/ Nota: Los jugadores del mismo color de equipo debería tener Manijas (#16) sobre el mismo lado, y los jugadores de cada equipo debería afrontar a su opositor.

/ Note: Les joueurs de la même couleur d'équipe doivent avoir leurs Poignées (#16) du même côté et chaque équipe faire face à l'équipe opposée.



- (15)  X 8
- (16)  X 8
- (17)  X 8

FIG. 7

The Hole / El agujero

FIG. 7A

(17)

(16)

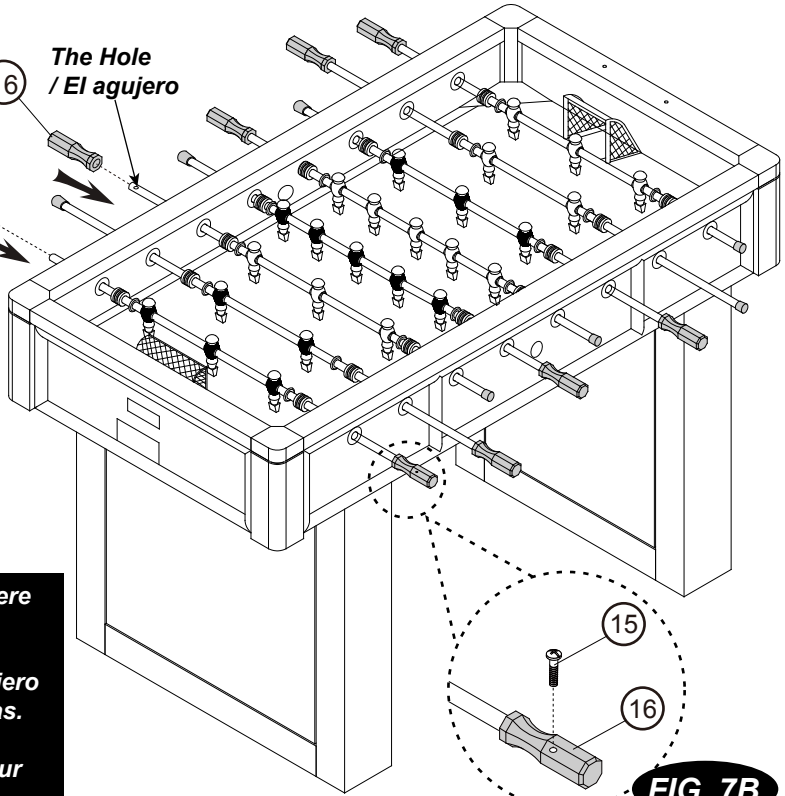

FIG. 7B

Note: The Rods have a hole at the end where their Handles will go.

/ Nota: Las Barras de Jugador hay un agujero en su parte final donde coloque las Manijas.

/ Note: Les Tiges joueur ont un orifice à leur extrémité où placer les Poignées.





- (20)  X 2
- (21)  X 4
- (22)  X 2
- (23)  X 2

FIG. 8



(1)

(23)

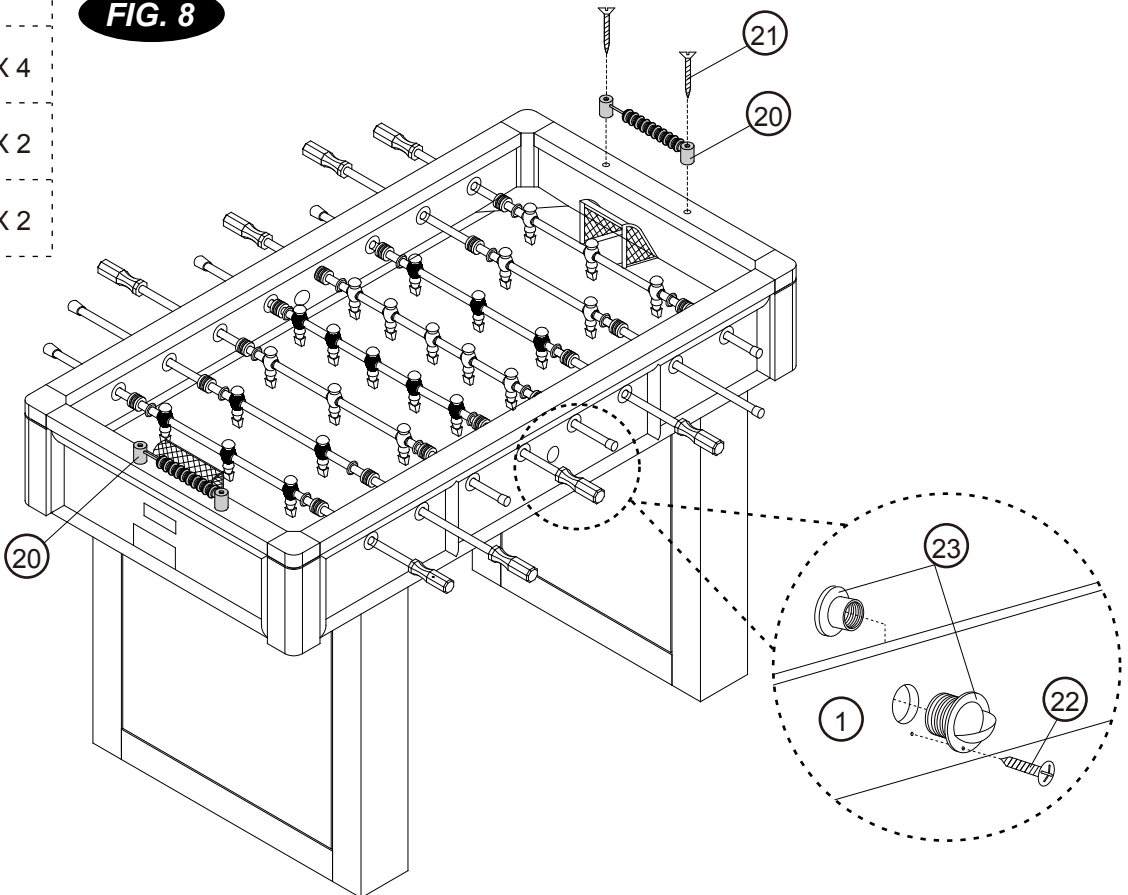
(22)

(21)

(20)

(20)

29



X 2

FIG. 9

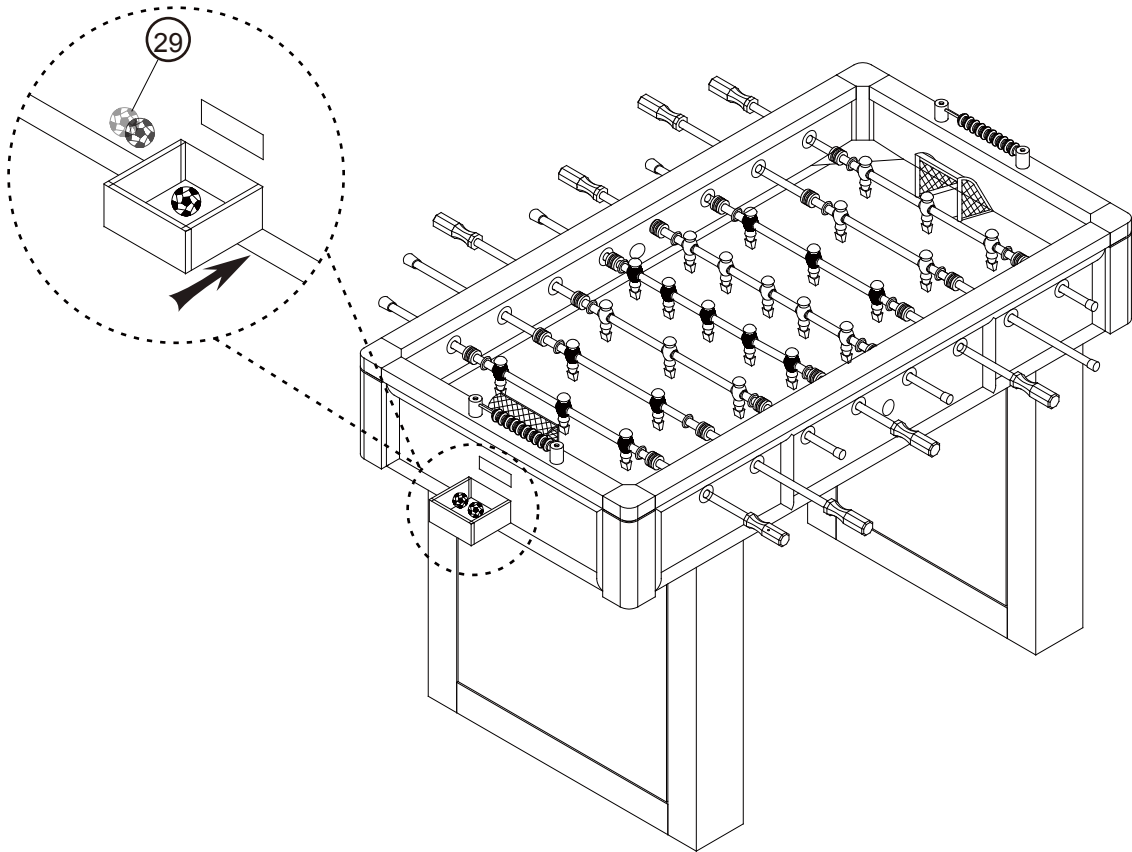

YOU ARE NOW READY TO PLAY!

¡USTED ESTA AHORA LISTO PARA JUGAR!

VOUS POUVEZ MAINTENANT COMMENCER A JOUER !