

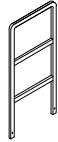









For assistance or missing parts in the USA please: E-MAIL: OIA\_SERVICE@OIANH.COM  
 or write to: Customer Service Department, Missing Parts  
 24 RIVER ROAD, SUITE #201, BOGOTA, NJ 07603, U.S.A.  
 Please call between 10am to 12pm or 2pm to 4pm  
 Monday thru Friday Eastern Standard time at (201) 488-0808  
 All international (outside USA) customers requesting missing parts, defect or damages must  
 contact the retailer directly to make an exchange or return for credit.  
 All other customer service product and/or questions may be directed to us.

## STYLE: 29946

#	①	②	③	④	⑤	⑥	⑦	⑧
PARTS								
QTY	1	2	2	4	1	1	2	2

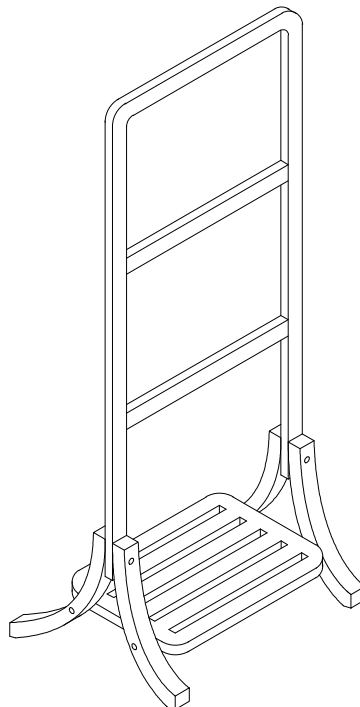

**Please Note** Parts Request:

We will accept missing parts requests with proof of purchase only, and within 30 days of purchase.

Return merchandise:

All return merchandise must be returned directly to the store not manufacturer with proof of purchase.

**ORGANIZE IT ALL, INC.**

The NEU HOME logo is a registered United States trademark of ORGANIZE IT ALL, INC.

A

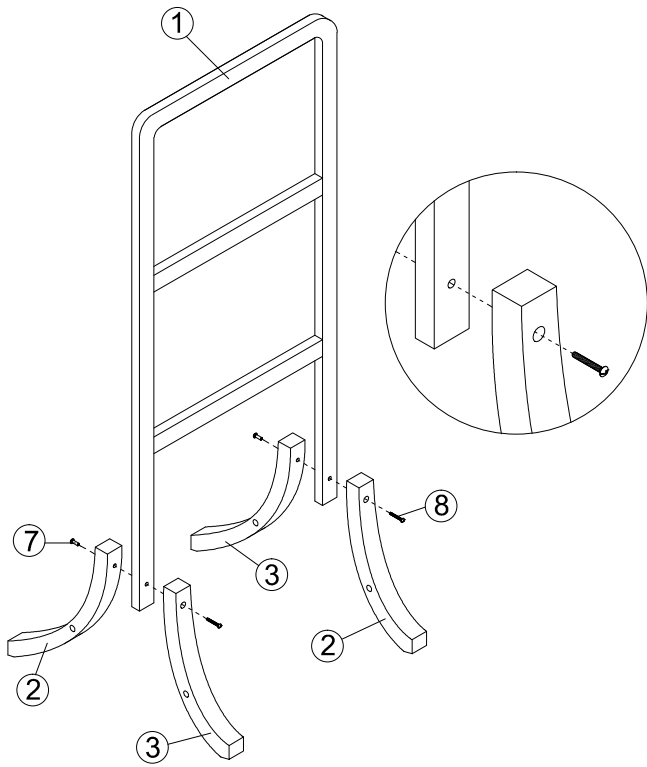

B

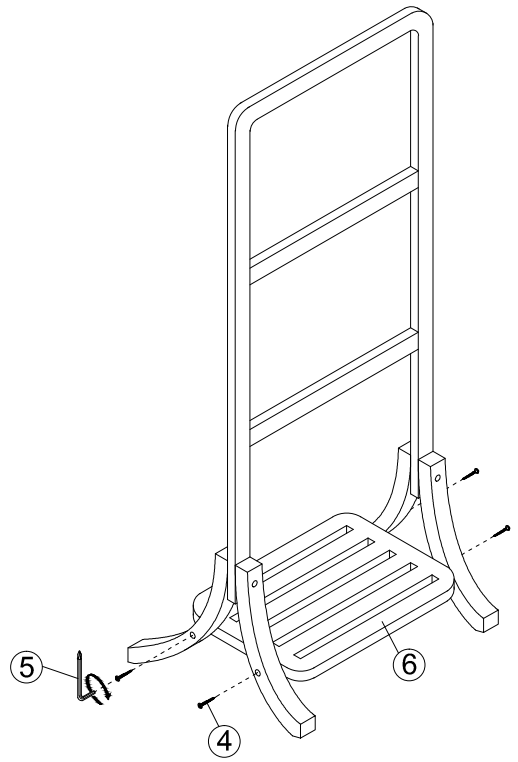

C

