



x2 All buildings should be erected by two adults



Winter = High Moisture = Expansion
Summer = Low Moisture = Contraction



2mm Drill bit

For ease of assembly, you MUST pilot drill all screw holes and ensure all screw heads are countersunk.



CAUTION
Every effort has been made during the manufacturing process to eliminate the prospect of splinters on rough surfaces of the timber. You are strongly advised to wear gloves when working with or handling rough sawn timber.



For ease of assembly, you will need a tape measure to check dimensions of components.

Protim Aquatan T5 (621)

Your building has been treated with Aquatan.

Aquatan is a water-based concentrate which is diluted with water, the building as been treated by the correct application of Aquatan solution and then allowed to dry.

Aquatan is a decorative finish to colour the wood, which is applied industrially to timber fence panels and garden buildings.

Aquatan undiluted contains: boric acid, sodium hydroxide 32% solution, aqueous mixture of sodium dioctyl sulphosuccinat and alcohols: 2, 4, 6-trichlorophenol.

BEFORE YOU START PLEASE READ INSTRUCTIONS CAREFULLY

- Check the pack and make sure you have all the parts listed.
- When you are ready to start, make sure you have the right tools at hand (not supplied) including a Phillips screwdriver, Stanley knife, Wood saw, Step ladder, Hammer and a Drill with 2mm bit.
- Ensure there is plenty of space and a clean dry area for assembly.

TIMBER

As with all natural materials, timber can be affected during various weather conditions. For the duration of heavy or extended periods of rain, swelling of the wood panels may occur. Warping of the wood may also occur during excessive dry spells due to an interior moisture loss. Unfortunately, these processes cannot be avoided but can be helped. It is suggested that the outdoor building is sprayed with water during extended periods of warm sunshine and sheltered as much as possible during rain or snow.

Our buildings are pre treated with a water based treatment**; this only helps to protect the product during transit and for up to 3 months against mould. To validate your guarantee and ensure longevity of the product, it is ESSENTIAL the building is treated with a wood preserver within the first three months of assembly and thereafter in accordance with the manufactures recommendations. Care must be taken to ensure the product is placed on a suitable base.

BUILDING A BASE

When thinking about where the building and base is going to be constructed: Ensure that there will be access to all sides for maintenance work and annual treatment.

Ensure the base is level and is built on firm ground, to prevent distortion. Refer to diagrams for the base dimensions, The base should be slightly smaller than the external measurement of the building, i.e. The cladding should overlap the base, creating a run off for water. It is also recommended that the floor be at least 25mm above the surrounding ground level to avoid flooding.

TYPES OF BASE

- Concrete 75mm laid on top of 75mm hard-core.
- Slabs laid on 50mm of sharp sand.

Whilst all products manufactured are made to the highest standards of Safety and in the case of childrens products independently tested to EN71 level, we cannot accept responsibility for your safety whilst erecting or using this product.

Refer to the instructions pages for you specific product code

Overall Dimensions:

Length = 2411mm
Width = 2484mm
Height = 2569mm

Base Dimensions:

Length = 2350mm
Width = 2360mm

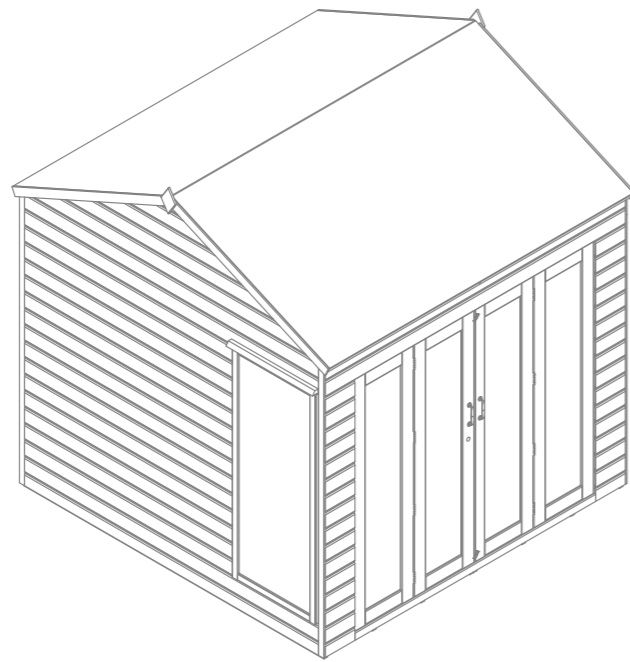

Pre Assembly

Remove the transportation blocks from the bottom and top of each panel before beginning assembly

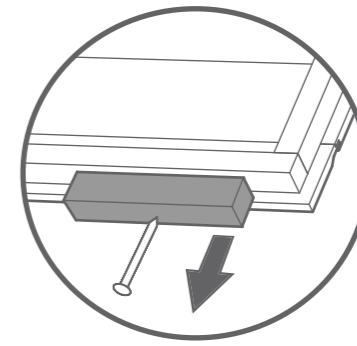

Step 1

Attach the side doors to the inside framing of the door panel using 3x butt hinges per door.

* Fix to the door using 3x25mm screws & 3x30mm screws to the framing per hinge, ensure the doors open freely, folding back into the building unrestricted.

18x25mm Screws
18x30mm Screws

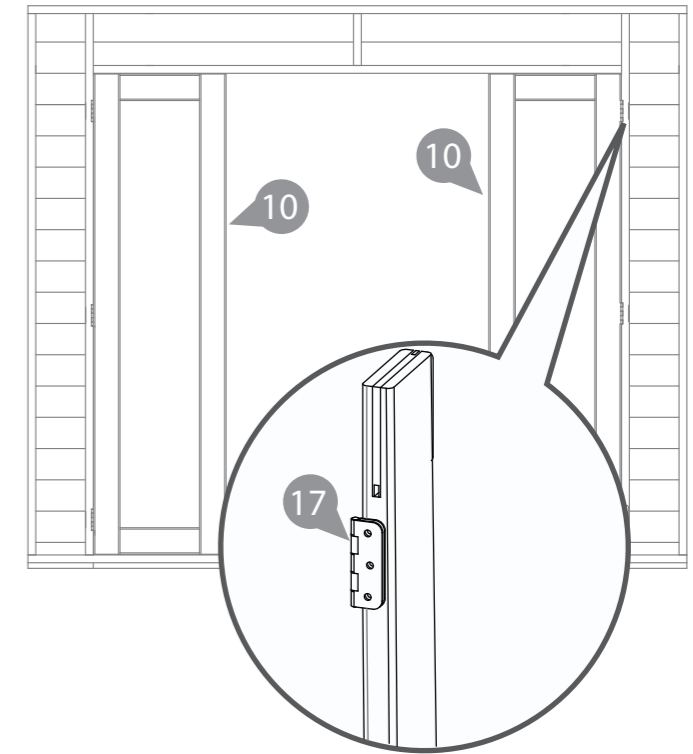

Fix the hinge flaps to the inside of the doors both on the interior and exterior.

Step 2

Fix the master and slave door to the attached side doors with 8x butt hinges, using 6x25mm screws per hinge.

*Ensure the doors open freely, folding back into the building unrestricted.

48x25mm Screws

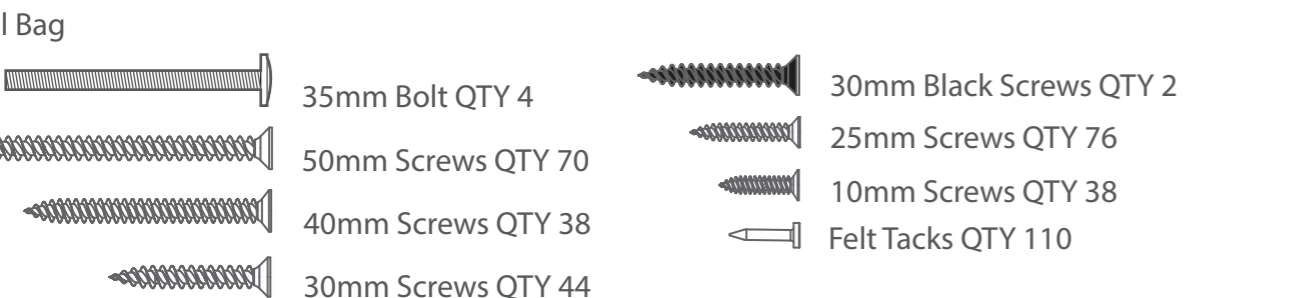
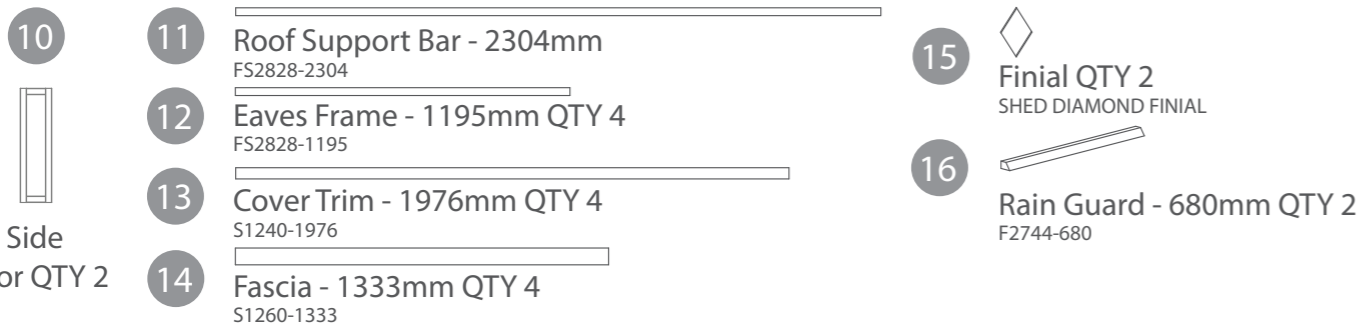
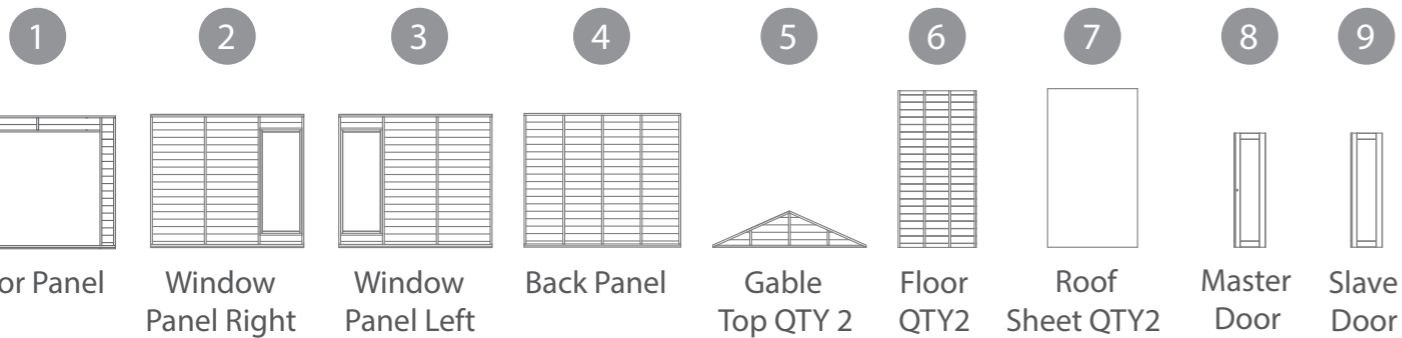
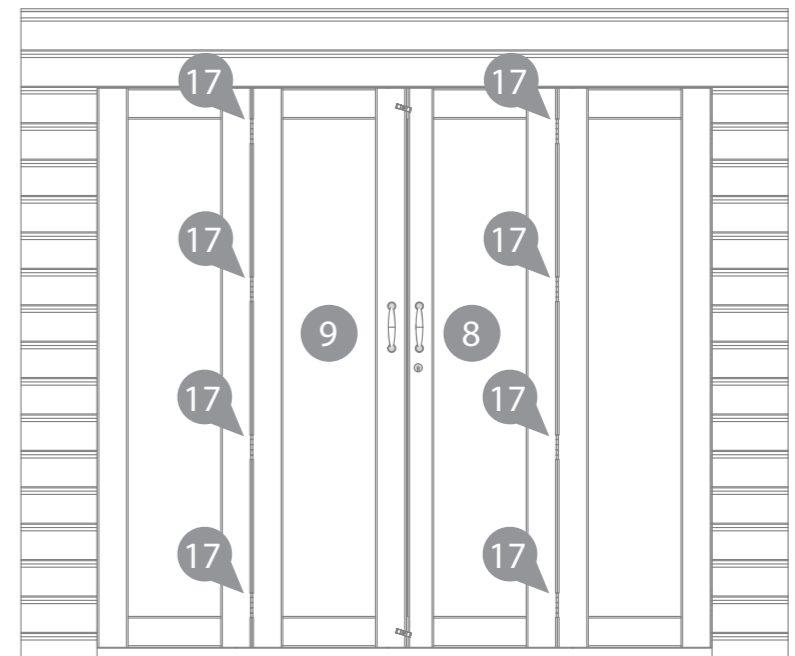

Step 3

Secure the barrel bolts to the top & bottom of each side door and the slave door using 6x10mm screws.

Attach the press lock to the master door with 4x25mm screws, aligning the barrel with the key hole.
*Ensure the key turns and locks properly before fixing to the door.

Fix the door handles to the outside of the master and slave door using the 35mm bolts provided.

36x10mm Screws
4x25mm Screws
4x35mm Bolts

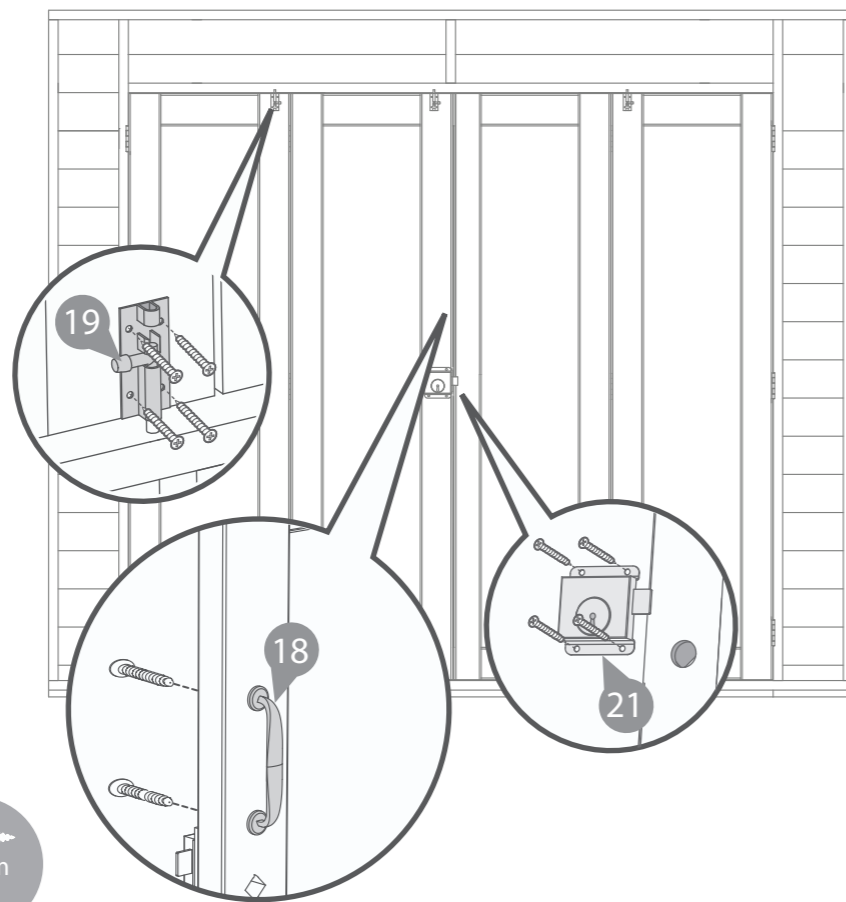

Step 4

Place the floor panels upside down onto a firm and level base. Ensure the base has suitable drainage, free from areas where standing water can collect.

Secure the floors together using 8x50mm screws through the floor bearers in an alternating pattern.

Once fixed together turn the floor back the right way up.

8x50mm Screws

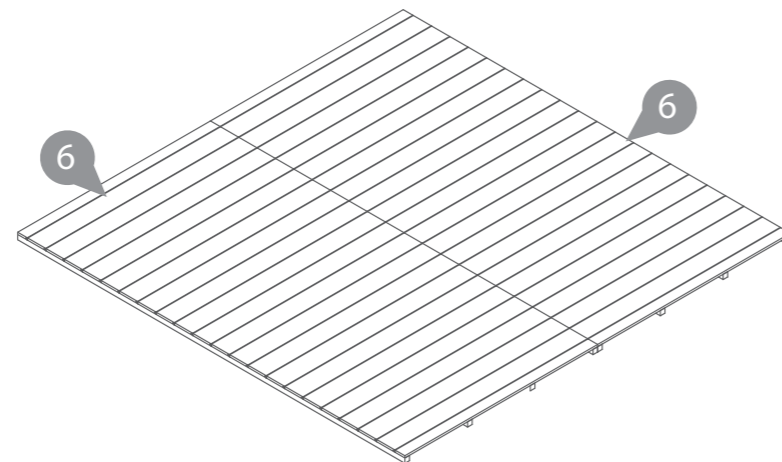
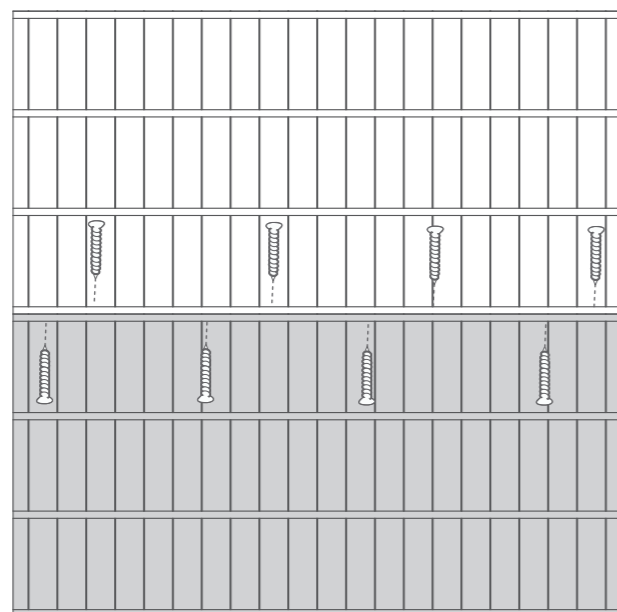

Step 5

- a** Fix the corners with 50mm screws as shown in the illustration.
- b** Do not secure the building to the floor until the roof fitted.

3x50mm Screws

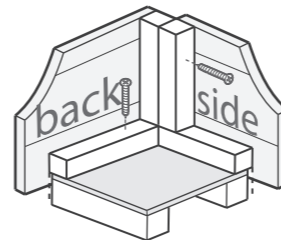

Step 6

- a** Fix the corners with 50mm screws as shown in the illustration.
- b** Do not secure the building to the floor until the roof fitted.

9x50mm Screws

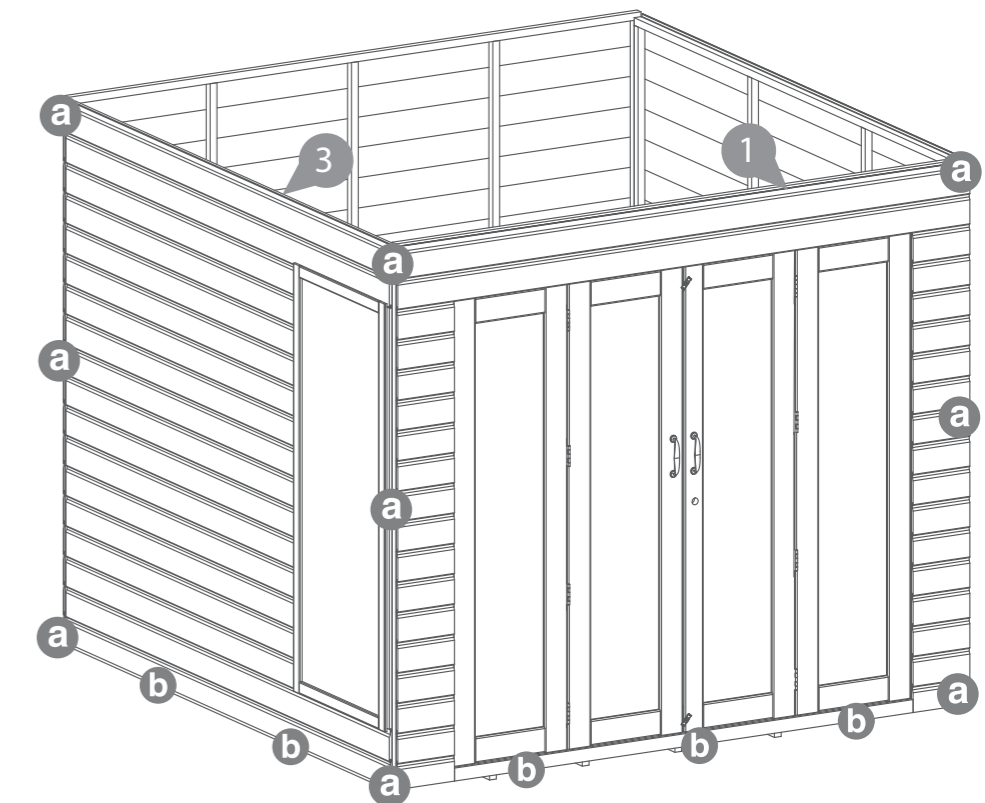
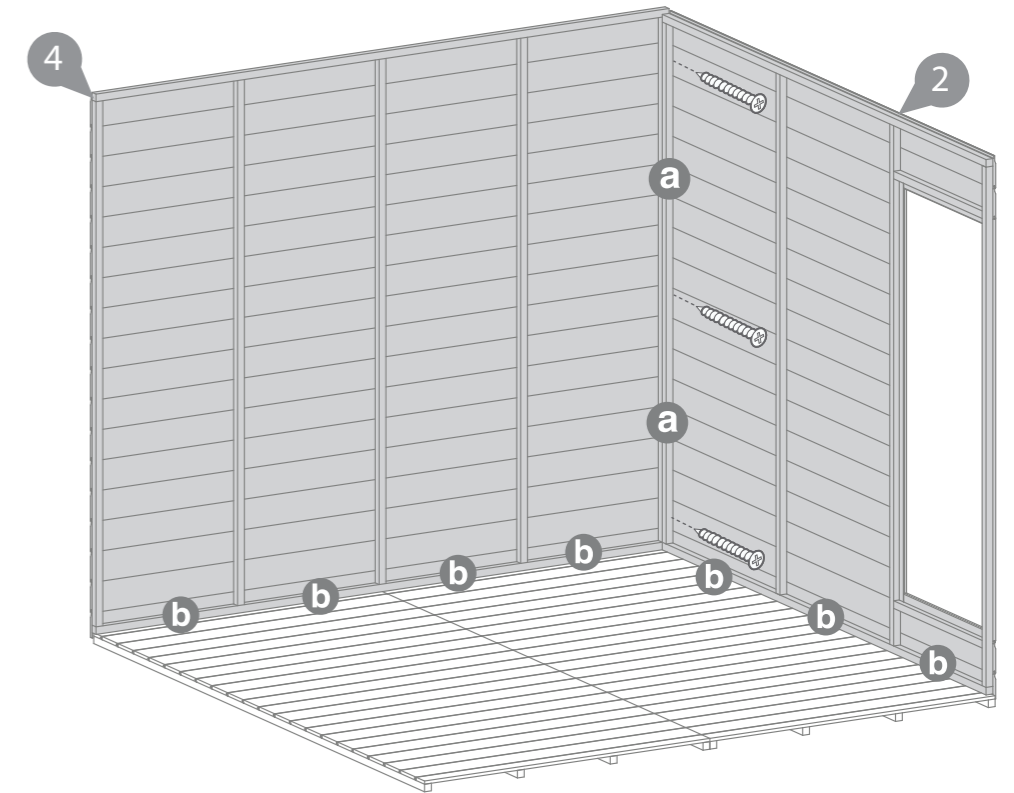
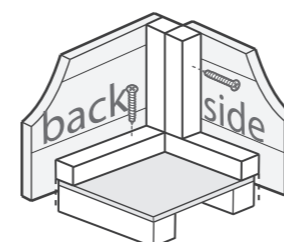

Step 7

Place the gable tops onto the window panels, ensuring the boards interlock.

Secure in place using 4x50mm screws per gable top, screwing in an alternating pattern.

8x50mm Screws

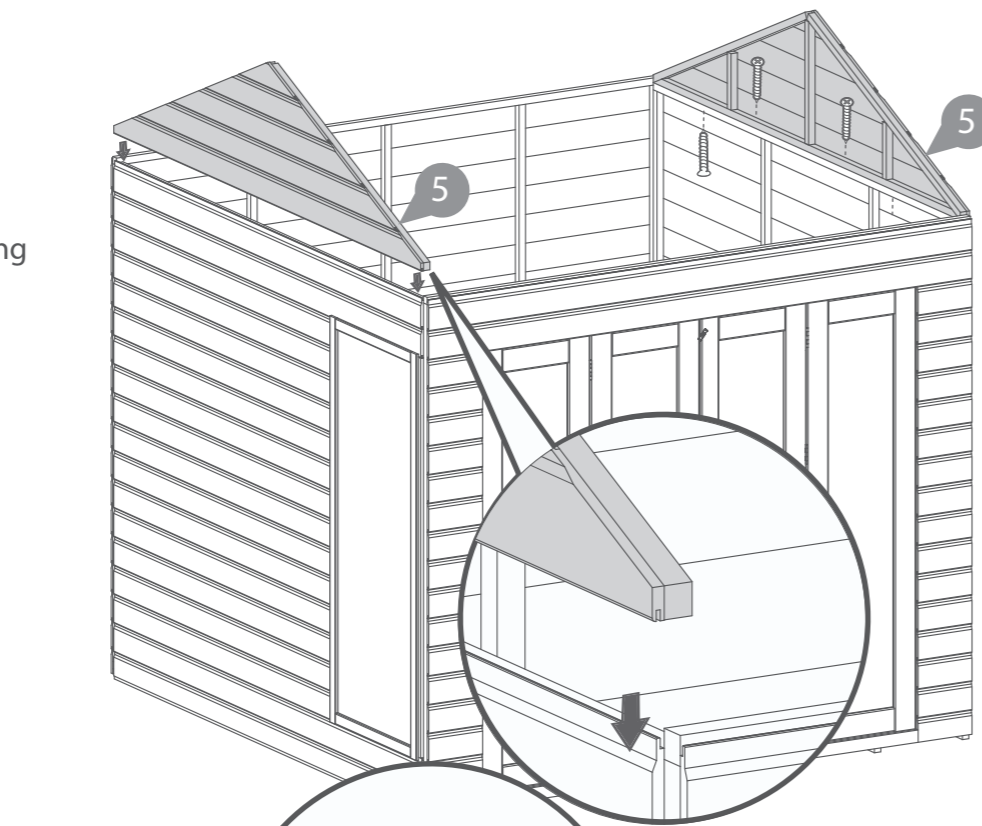

Step 8

Attach the "L" brackets to each end of the ridge bar with 2x25mm screws per bracket.

*Ensure the brackets are flush with the ends of the ridge bar.

Align the ridge bar between the gables and secure to the central uprights with 2x25mm screws per bracket as shown in the illustration.

8x25mm Screws

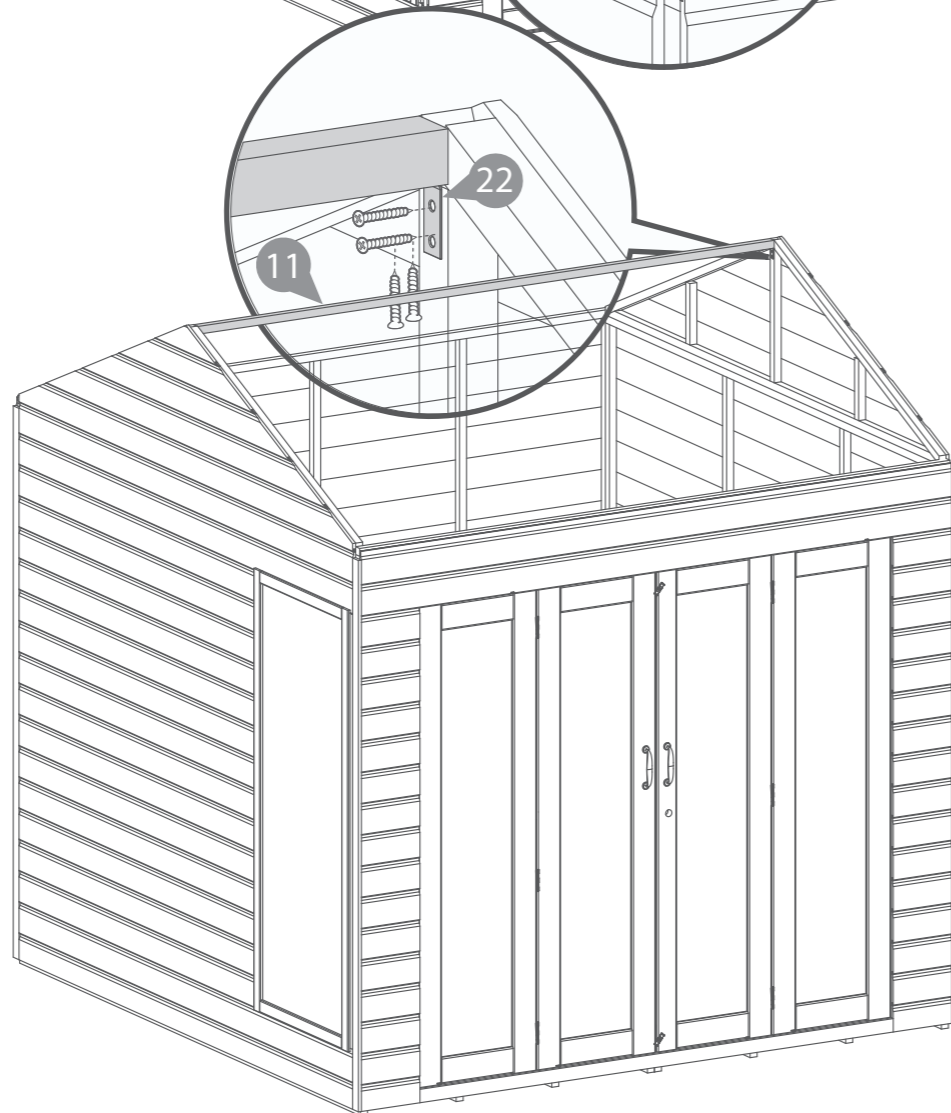

Step 9

Attach 2x eaves frames to the long side of each roof sheet, ensuring the frames are flush to the edges, securing in place with 3x30mm screws per frame.

Place each roof sheet onto the building and fix into place using 12x40mm screws per roof.

12x30mm Screws
24x40mm Screws

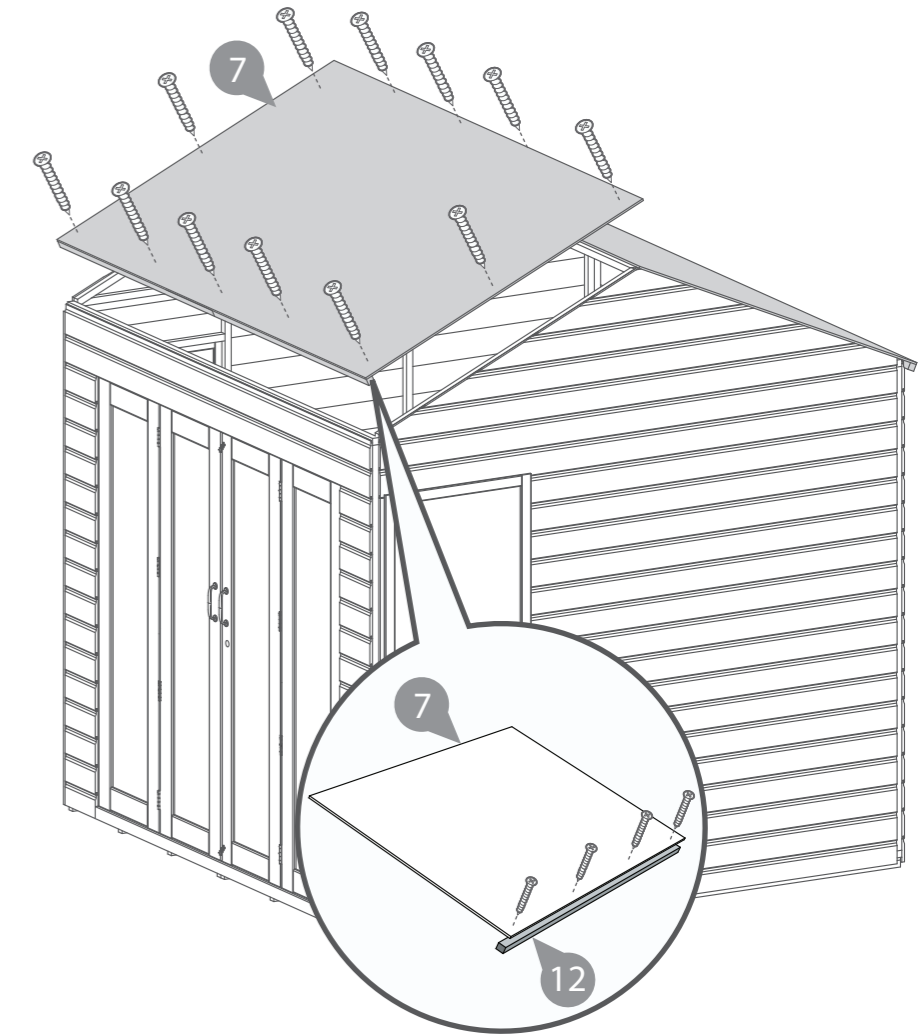
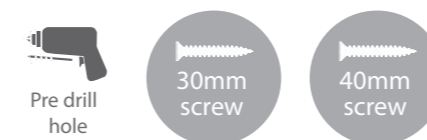

Step 10

b Secure the building to the floor using 36x50mm screws.

*Ensure to screw through the framing into the floor bearers.

36x50mm Screws

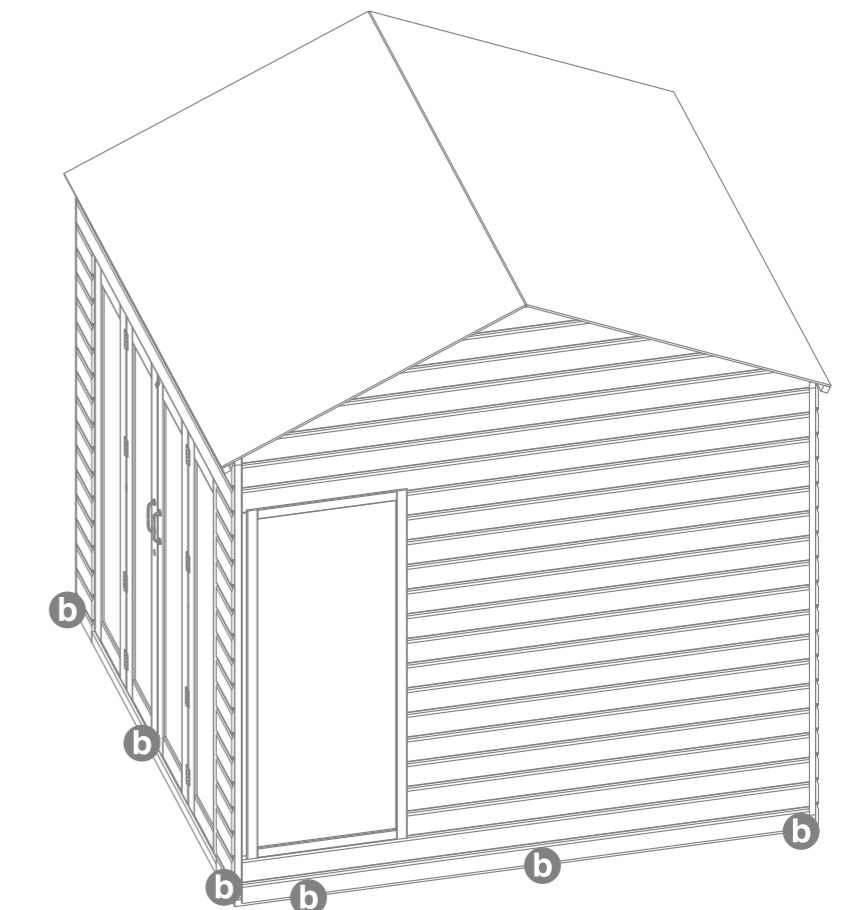
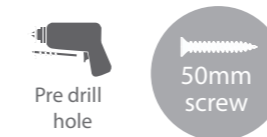

Step 11

Cut the felt into 3 strips of 2500mm length and place onto the roof, as shown in the illustration.

*Ensure there is approximately 50mm overhang of felt around all sides of the building.

Fix into place using 110x felt tacks at 100mm intervals.

110x Felt Tacks

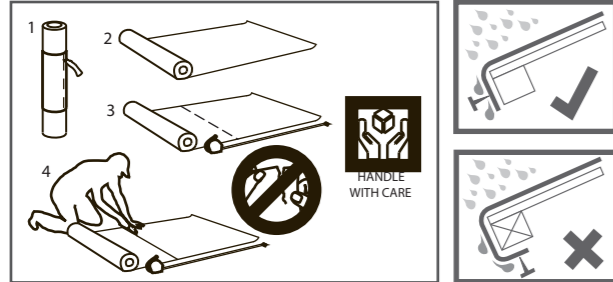
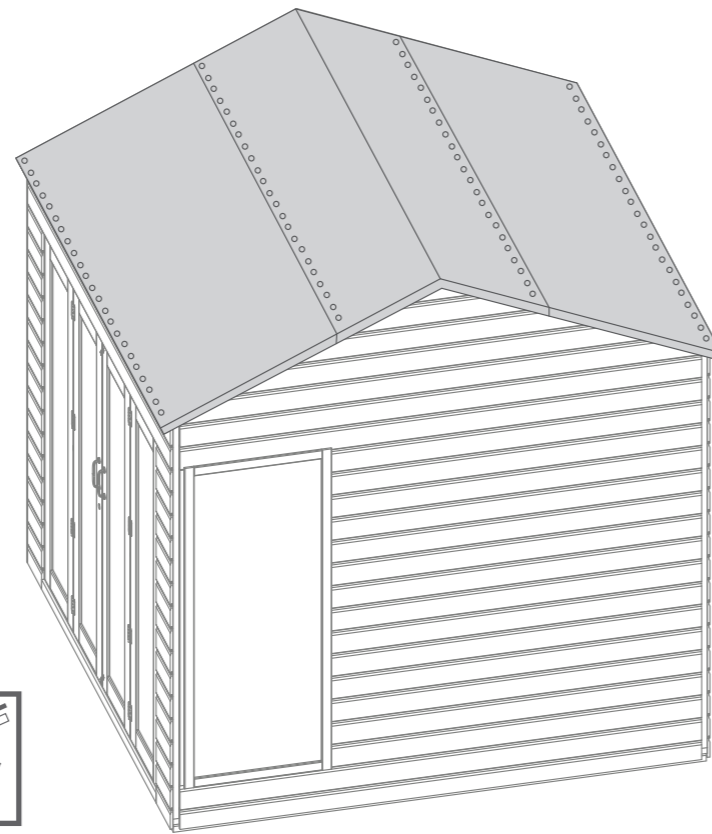

Step 12

Screw the cover trims to each corner of the building with 3x30mm screws per trim.

12x30mm Screws

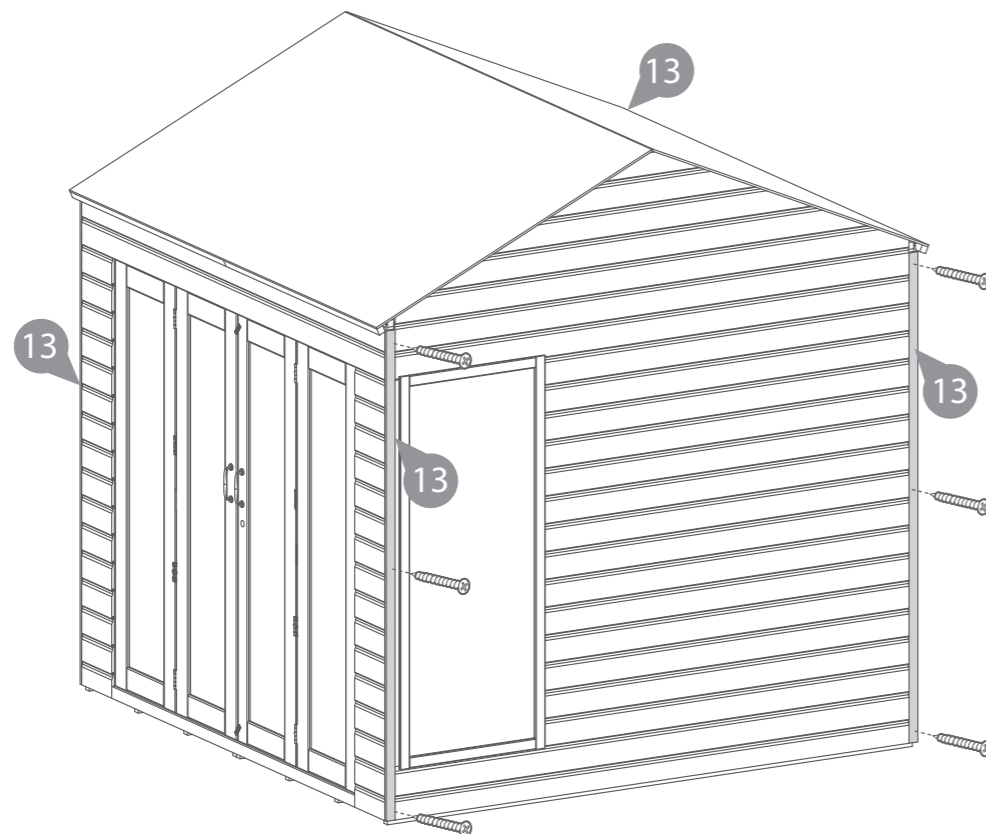

Step 13

Attach the fascia's and finial's to the the front and back of the building using 12x40mm screws.

12x40mm Screws

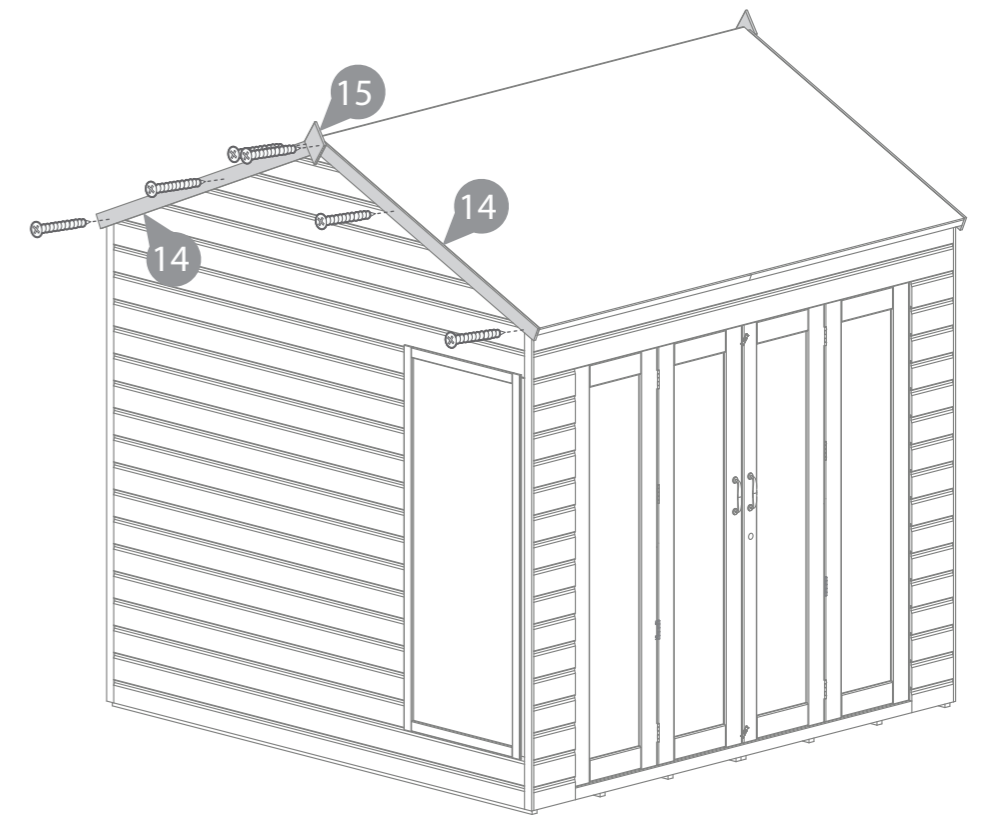

Step 14

Fix the rain guards above each window, securing in place using 2x50mm screws per guard, ensuring to screw through the framing.

4x50mm Screws

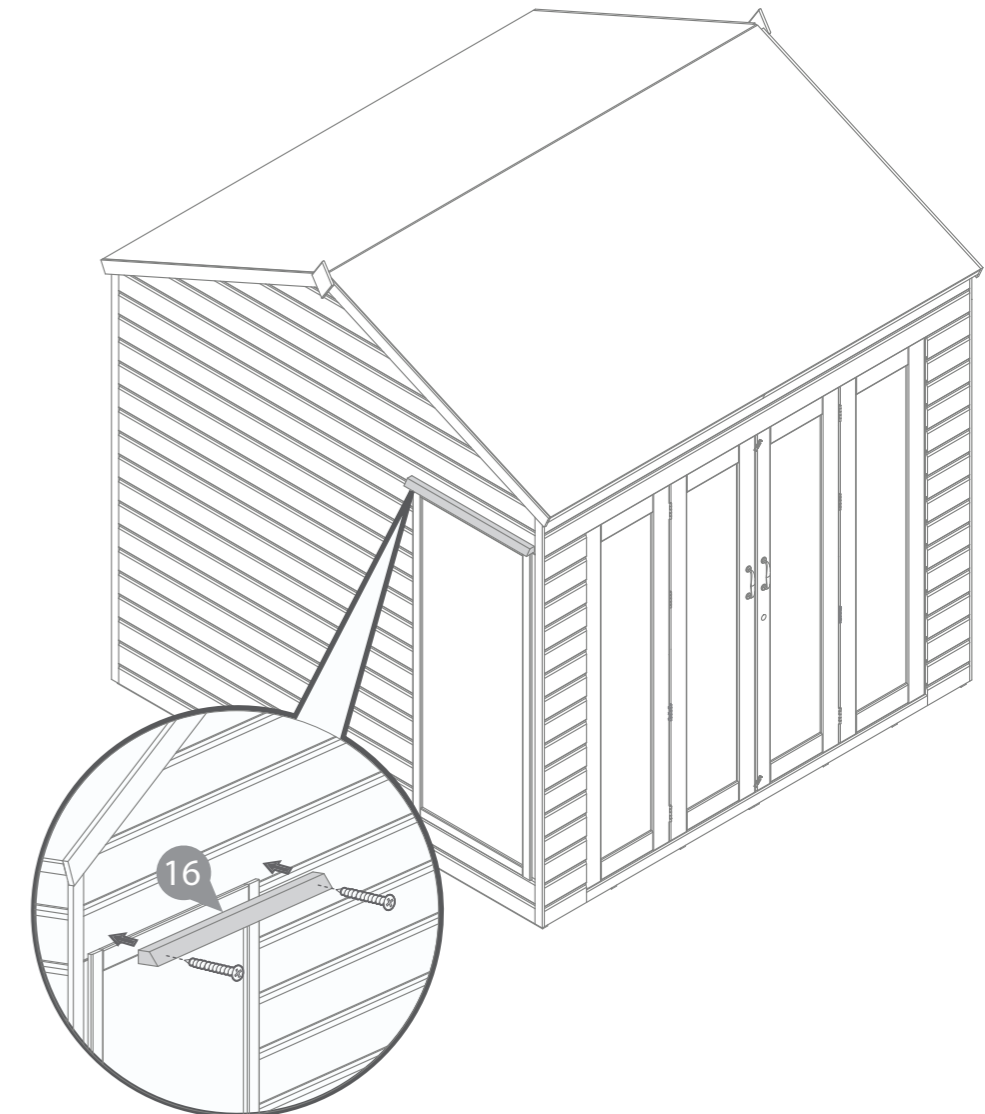
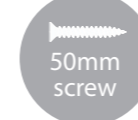

Step 15

Place the Door support bar (No. 24) to the inside of the door panel as displayed on the pictures.

This framing will meet at each side panel as show in image 2.

The 44mm side of the framing should sit against the inside of the door panel, matching the width of the door frame timber.

*Ensure that the framing is attached in a straight line matching the line of the top of the door frame.

*Please be aware this piece of framing may need to be adjusted to length by customer in regards of building tolerances. This piece of framing should fit tightly between the two side panels.

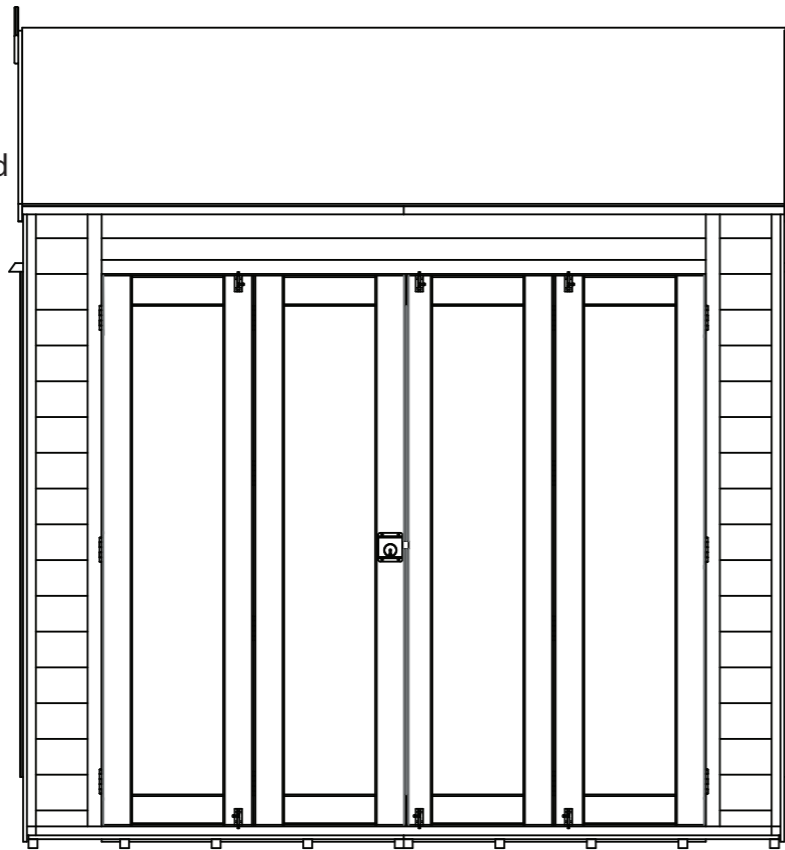

BEFORE

Step 16

Screw through the side panel externally in line with the 2 x 1 framing using 1 x 70mm screw in either side to secure the framing in place.

Screw through the front panel externally with 4 x 70mm screws equally spaced a part along the door frame to secure the 2 x 1 framing to the panel.

*Please ensure you pre-drill prior to screwing into the panel to eliminate the chances of the timber splitting.

A Drill 3 x 6mm holes into the 2 x 1 framing in line with your barrell bolts. These will act as the catch for the barrell bolts at the top of your door.

* Ensure the holes are drilled in to the 2 x 1 framing attached in step 15 as oppose to the door frame.

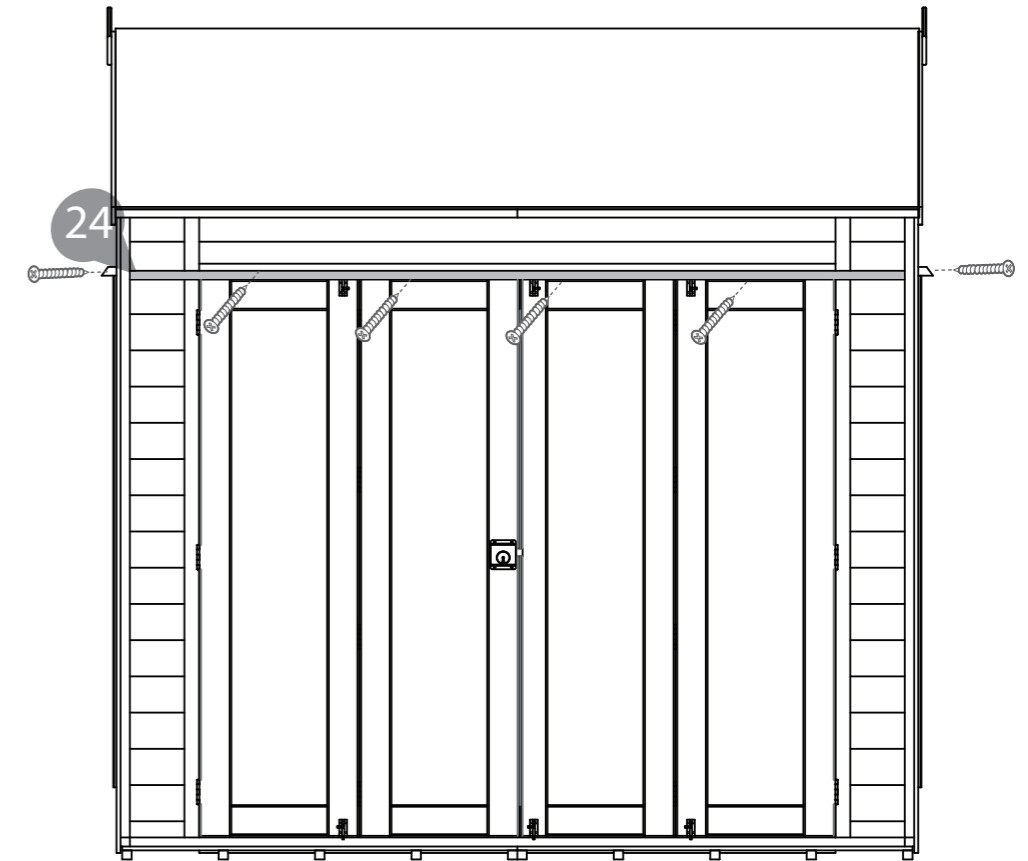

AFTER

Step 17

Attach the two turn buttons to the slave door at the top and bottom using 2x30mm black screws.

2x30mm Black Screws

*These turn buttons help to keep your doors straight during high & low levels of moisture content in the air.

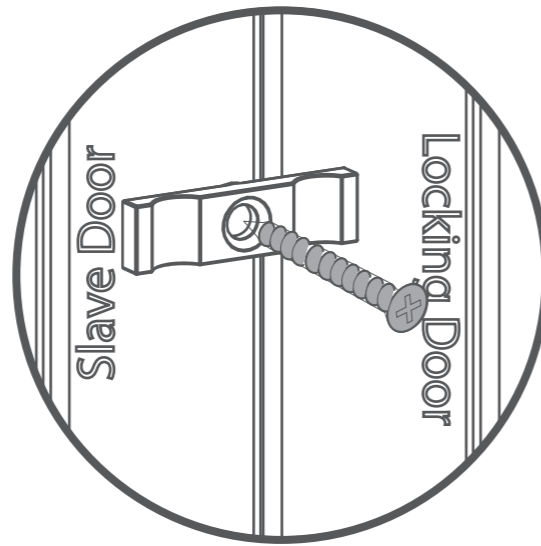

Step 18

Attach a strip to the hinged side of the middle opening doors.

*These strips allow you to adjust the doors allowing for moisture absorption and reduction.

6x30mm Screws

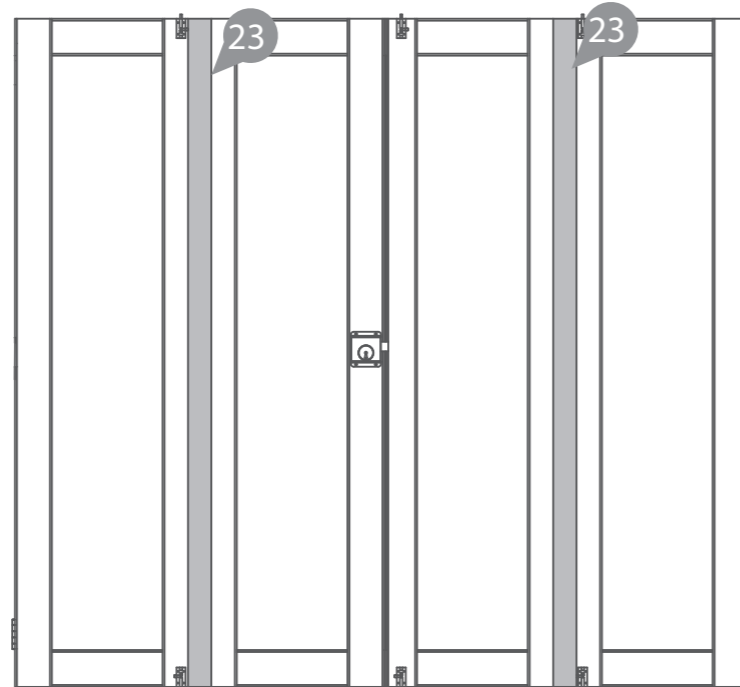

Step 19

it is recommended that after the construction, treatment and the removal of the protective window cover that sealant is used to keep the building weather tight.

