

**OC9168R0TX**

**"MIRAGE" MIRRORED ACCENT  
TABLE**

**Assembly Instructions**



**Southern  
ENTERPRISES**

For assistance with assembly contact:

Southern Enterprises Inc.

Customer Service 1-800-633-5096

[service@seidal.com](mailto:service@seidal.com)

[www.seidal.com](http://www.seidal.com)





**PO# :**

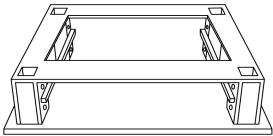
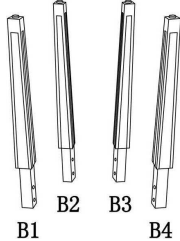
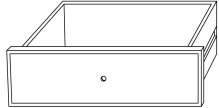
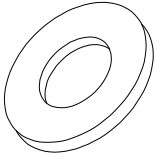
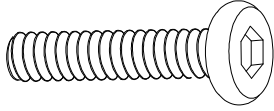

# "MIRAGE" MIRRORED ACCENT TABLE

## Parts List

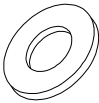
Please review all parts and hardware before disposing of any packaging.  
 Call Customer Service if missing hardware. Using a screw that is too long will cause damage. Before beginning assembly, separate each type of screw. Carefully study the screw diagrams below.

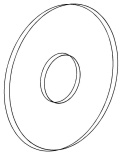
<p><b>A</b> Quantity Of 1</p>  <p>Table Frame</p>	<p><b>B1/B2/B3/B4</b> Quantity Of 4</p>  <p>Leg</p>	<p><b>C</b> Quantity Of 1</p>  <p>Drawer</p>
<p><b>1</b> Quantity Of 8</p>  <p>Big Flat Washer</p>	<p><b>2</b> Quantity Of 8</p>  <p>Hex-head bolt</p>	<p><b>3</b> Quantity Of 1</p>  <p>Allen Wrench</p>
<p><b>4</b> Quantity Of 1</p>  <p>Knob</p>	<p><b>5</b> Quantity Of 1</p>  <p>Small Flat Washer</p>	<p><b>6</b> Quantity Of 1</p>  <p>Small Bolt</p>
<p><b>7</b> Quantity Of 1</p>  <p>Plastic Washer</p>		

**Care and Cleaning Instructions:**

Before using, wipe with a clean, dry cloth.  
 Avoid rubbing or scratching the surface with rough or abrasive objects.

For replacement parts or questions, please call Customer Service at 1-800-633-5096.

Please call manufacturer for assistance, questions or parts.

**Assembly Tool Required  
 No.2 Phillips Screwdriver**

**Not Included**

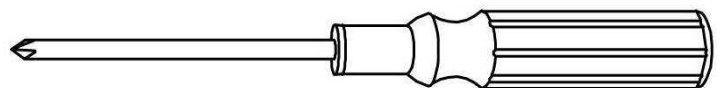

# "MIRAGE" MIRRORED ACCENT TABLE

## Assembly Instructions

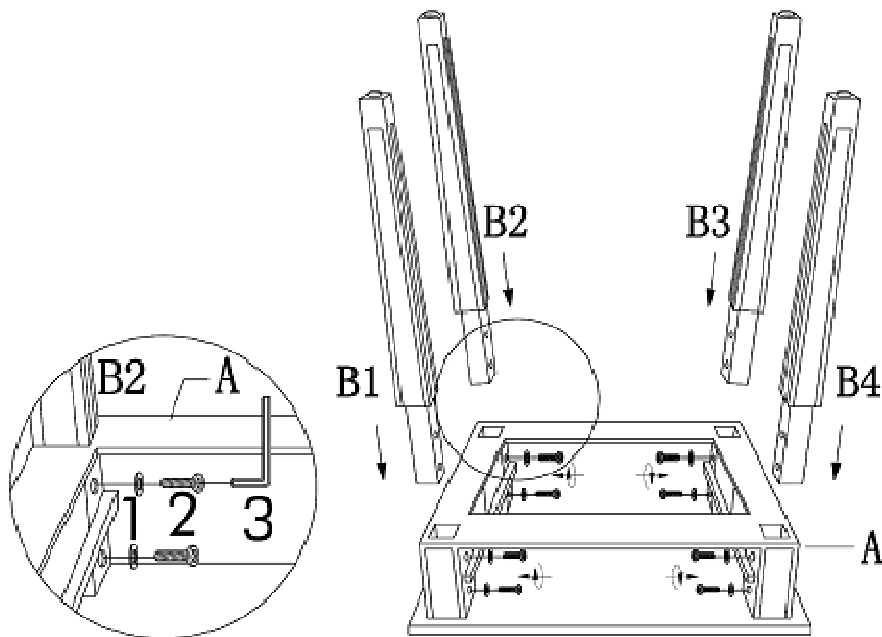

Figure 1

Assembly Instructions:

Be careful when assembling. Do not scratch.

Step 1 Unpack and lay parts on clean, padded surface like carpet or blanket. Check that you have all parts indicated on the front page.

Step 2 Attach legs (B1B2,B3,B4) to Table Frame (A) using bolt (2) with washer(1). Tighten bolts with Allen wrench (3).

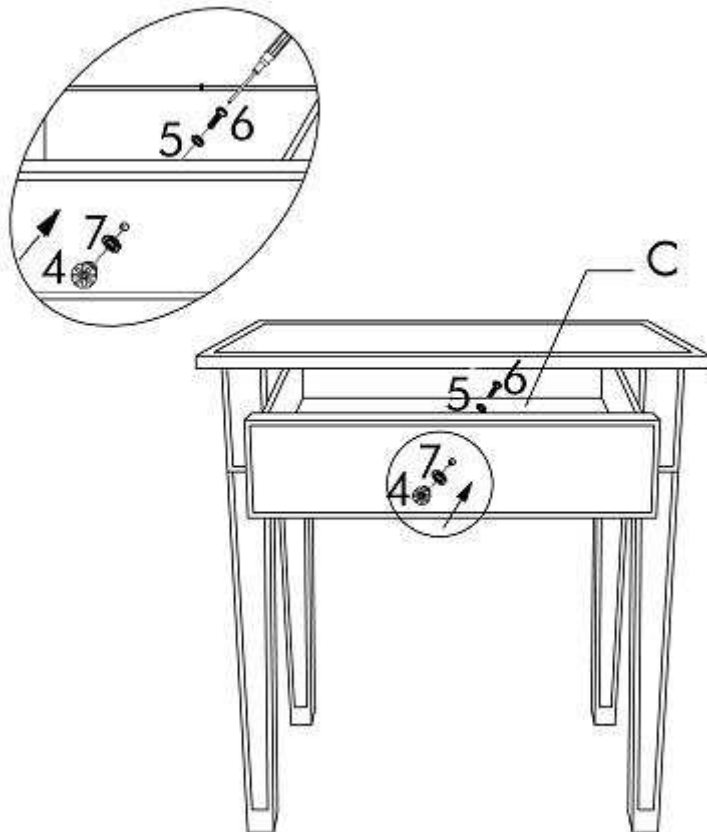

Figure 2

Step 3 Insert drawer (C) to the assembled unit.

Step 4 Attach Knob (4), Plastic Washer (7) to the front panel of drawer (C) using Small Bolts (6) and Small Washer (5). Tighten with screwdriver (not included) as shown in figure 2.

Now your new accent table is ready to use.

# Parts Replacement Form

## Customer Information

Name \_\_\_\_\_

Address \_\_\_\_\_

City/State/Zip Code \_\_\_\_\_

Phone Number \_\_\_\_\_

Please indicate where you purchased this item: Store/Website/Catalog

\_\_\_\_\_

Please indicate color/size/style number:

\_\_\_\_\_

Style No	Parts Letter	Parts Description	Quantity Needed
----------	--------------	-------------------	-----------------

\_\_\_\_\_

\_\_\_\_\_

\_\_\_\_\_

Please immediately examine this product carefully. Any request for missing parts or damage replacement must be received within 90 days of your receipt of the product. Replacement, if available, will be honored within this time frame. Parts will not be available for items arriving fully assembled. We do not recommend modifying product(s) and we are not responsible for any damages due to product modification(s). If damages or missing parts are not reported within 90 days of your receipt, we are under no obligation to provide parts or replacement merchandise.

Please contact Southern Enterprises at 800-633-5096 or in Dallas 972-869-0111/ 9am – 4pm Mon-Fri Central time if you have product issues or email us at [service@seidal.com](mailto:service@seidal.com). Please ask for customer service representative for issues involving damages or replacement parts. Please ask for technical assistance representative for any issues with product and assembly/construction.

Please contact the retailer that you purchased from for returns.



**Southern**  
ENTERPRISES

Customer Service 1-800-633-5096  
[service@seidal.com](mailto:service@seidal.com)  
Southern Enterprises, Inc.  
600 Freeport Parkway, Suite 200  
Coppell, Texas 75019