

Corona Concepts presents

The Orchid
All Wood Dollhouse



**Instruction and
Assembly Guides**

Introduction

In Short...Welcome to the exciting world of dollhouses and miniatures. Since the first tab and slot die-cut dollhouse kits arrived on the scene in the mid 1970's, their design and styling concepts have evolved swiftly. However, complexity of construction has always accompanied the great design and styling.

As pioneers in the early days of the die-cut dollhouse industry, the designers for Corona Concepts have utilized a simpler method for building dollhouses. This kit has been designed with efficiency in mind. It has fewer complicated interlocking parts, while retaining the detail and realism necessary in the miniature industry.

We feel you will find that this kit will be an enjoyable and rewarding project. If you are just beginning to discover the wonderful world of miniatures, we hope that the simplicity of this kit will be a pleasant introduction to the craft. If you are an experienced veteran, we hope you will appreciate the simple, straight forward construction and design.

Before beginning assembly, please read through all of the instructions carefully. There are tips and suggestions to aid you in assembly. By becoming familiar with the steps involved and the contents of the kit, the assembly process will become a rewarding experience and the end product will be one you can be justly proud of.

If you should have any questions or comments during the construction of your Orchid Dollhouse, do not hesitate to call us at (800) 253-7150. We are here to answer all of your questions as well as to hear your comments about our product. Feedback from you, the customer, is our only indication of how we're doing our job.

Have fun and thank you for purchasing our product!

Before You Begin

THIS KIT CONTAINS:

- ◆ Ten pre-cut wood sheets
- ◆ One silk-screened plastic window sheet
- ◆ One set of instructions
- ◆ One set of schematic diagrams

ITEMS YOU NEED TO SUPPLY:

- ◆ Lead pencil and eraser
- ◆ Emery board
- ◆ Newspapers or other drop cloth
- ◆ Masking tape
- ◆ Extra sandpaper
- ◆ Ruler or other straight edge
- ◆ Wood filler
- ◆ Stiff bristled brush
- ◆ Glue (**We recommend that you use a white tacky glue as Aleenes [can be found in Walmart] or Elmer's and hot glue only to tack. When applying white glue**

leave a few small empty spaces for hot glue.)

Tips for success!

1. Save the kit box as a safe "nest" for the wood sheets until all the parts have been removed from them. Also the photos on the outside of the box may be useful as a reference tool.
2. Set your work area up on a large flat surface with all of your supplies at hand. Consider an area that does not have to be "cleared" every day. Your project will take some time and if assemblies can remain in place until the paint or glue dries, it will be to your advantage.
3. Follow the instructions in order! Do NOT jump ahead or reverse the order of assembly.
4. Only remove parts from the pre-cut wood sheets as they are called for in the instructions. If there are parts that for any reason are removed from the sheet but not called for yet, write the sheet number on the cut out and re-file or tape the piece to the rest of that sheet.
5. When removing pieces from the pre-cut sheets, do so with extreme care. Some of these items are very detailed and somewhat fragile.
6. The schematic diagrams are labeled with the sheet number, part's names, part's orientation (i.e., left, right, interior, exterior, etc.), and where the tabs and slots fit (i.e., "front tabs" fit in piece labeled "front"). It is helpful to write in pencil this information on the pieces before removing them from the sheets. All markings can easily be erased later.
7. The instructions contain some abbreviations and terms which you will need to become familiar with:
 - ◆ **R&P** – (Remove & Prepare) This means to remove the specified part from the sheet by carefully punching the piece out from the front to the back of the sheet. Prepare the piece by carefully sanding any rough edges and painting, staining, or otherwise decorating as desired.
 - ◆ **(#)** - Numbers in parenthesis, i.e. (8), refers to the sheet number the piece required can be located on.
 - ◆ **(G)** – (Glue) This means that you may go ahead and glue the piece or pieces in place.
 - ◆ **Face Up** – Means laying the item down the smooth side up.
 - ◆ **Face Down** – Means laying the item down with the smooth side down.
 - ◆ **Front** – The front of any sheet is that side which is smooth and the die cut lines are clearly visible.
8. Always "dry fit" parts before gluing.
9. Paint or stain all window sashes and casings where place window will be glued BEFORE gluing on the plastic.
10. If staining, stain first, let dry, then proceed. If painting, do not paint tabs or inside of slots. Painting these areas will not allow parts to fit together properly. These areas can be touched up after assembly. Glue also tends to adhere

- better to wood than to a painted surface.
11. The plastic window sheet is susceptible to scratching. It should be protected from abrasive surfaces at all times.
12. Right and left are viewed from the front of the house.

Finishing Touches

Finishing your dollhouse is only limited by your imagination. Paint, wallpaper, stain and stucco are only a few of the items you can be creative with.

Wood fill and primer can be very helpful. Use the wood fill to smooth joints between tabs and slots and on corner seams. Primer is recommended to prime the wood with before painting. Parts to be stained should NOT be primed.

Satin finish latex house paint will give a better result than either flat or gloss finish.

Be sure to check your local craft shop for other decorative items such as siding, floor tiles, carpet, electrification kits, furniture, etc.

**IF ANYTHING IS MISSING CONTACT US AT
800-253-7150**

More Tips for Success!

- ◆ A well lit work area will work best!
- ◆ Don't glue anywhere except as specifically noted.
- ◆ Empty cans or containers will help keep things organized.
- ◆ Remember to use white glue when assembling plastic windows!
- ◆ A foam brush works best for staining!
- ◆ Sanding is easier if you wrap your sandpaper around a block of wood!
- ◆ Hot melt glue & glue guns may be found at your local hardware or craft store.

Assembly Instructions

A) ASSEMBLY OF DOUBLE HUNG SASHES & CASINGS, DORMER CASINGS, GABLE CASINGS, FRONT DOOR WINDOWS & TRIM, AND BAY WINDOW CASINGS

1. **R&P** eight double hung window sashes (8). Four are interior, four are exterior. Remove eight double hung windows from plastic window sheet. Position sashes **face down** and position plastic window centered on sashes – (G).

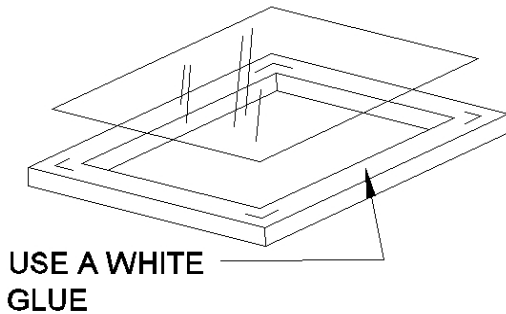

2. **R&P** two dormer window casings (3,6,7). Two are interior, two are exterior. We will be using just the two exterior for now. Remove dormer window from plastic window sheet. Position casings **face down** and position plastic windows centered on casings – (G).

3. **R&P** one gable window casing (2). Use exterior casing. Remove gable window from plastic window sheet. Position gable casing **face down** and position plastic window centered on casing – (G).

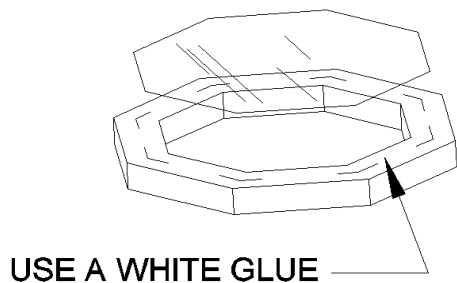

4. **R&P** front door (3) and front door trim (6). Remove front door window from plastic window sheet. Position front door trim (the large door overlay) **face down** and center window on the arched openings – (G).

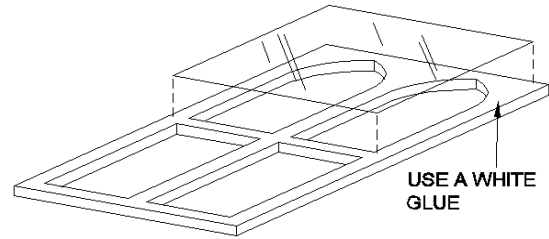

Large door trim piece (with window attached) and front door (3) can now be assembled. Lay front door **face down** and position large trim piece over it – (G).

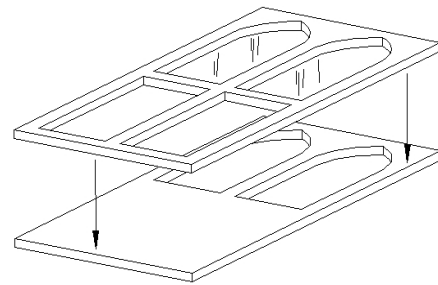

The two small rectangular panels are centered in the lower half of the front door rectangular cut outs – (G). Set aside front door.

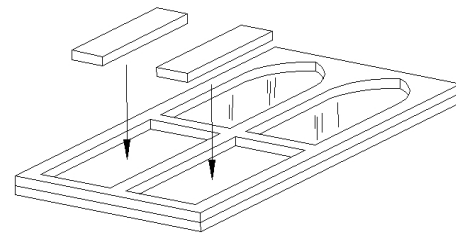

5. **R&P** bay window casings (2,5). Note and mark with pencil interior and exterior casings. Lay the two small and one large exterior casings **face down**. Remove the two small and one large bay windows from the plastic sheet. Center each on the exterior casings – (G).

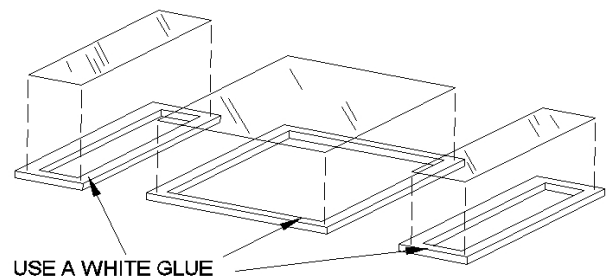

6. When dry – test fit the bay window interior casings to the backs of the exterior casings. Note that one side of the small casings is wider than the other. Position interior casings so that the inside of the window cutouts are flush and there is a recessed edge along each outside of the interior casings – (G).

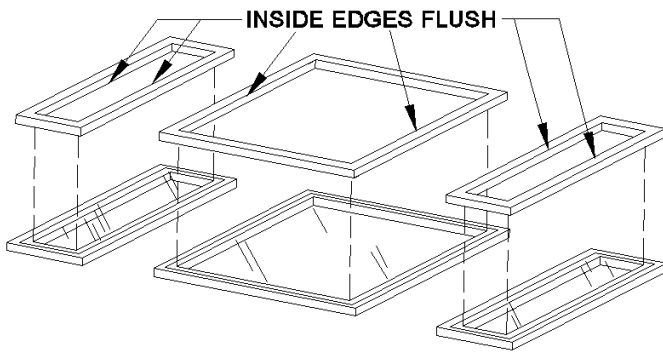
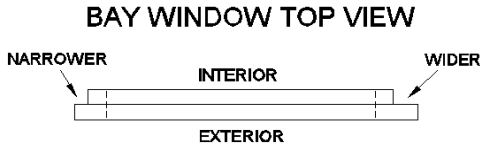

7. Lay aside all glued windows and allow to dry.

B) ASSEMBLY OF GLUED WINDOW SASHES AND CASINGS TO HOUSE

NOTE: To achieve the “double hung” effect, part of the house structure itself becomes one half of the window sash. Therefore, that portion of the wood surrounding the window opening, both interior and exterior, should be finished as the sashes have been (i.e., paint or stain) before gluing the sash in place.

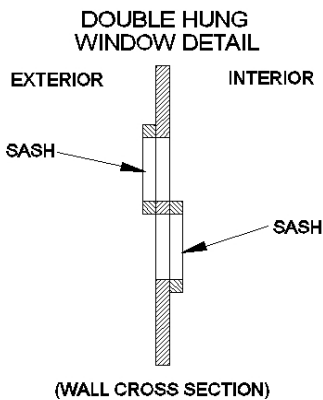

1. **R&P front (3), left side (4), and right side (5).** Lay these pieces **face down** and position one double hung sash over the **BOTTOM** opening of each window cut out in front and both sides – (G).

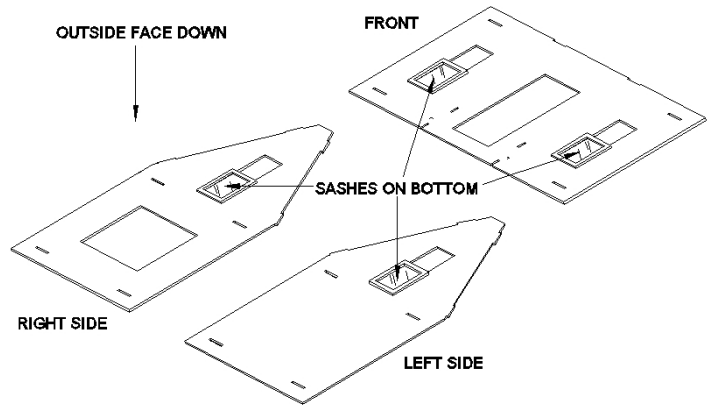

2. Turn the front and side panels **face up** and position one double hung sash over the **TOP** opening of each window cut out – (G).

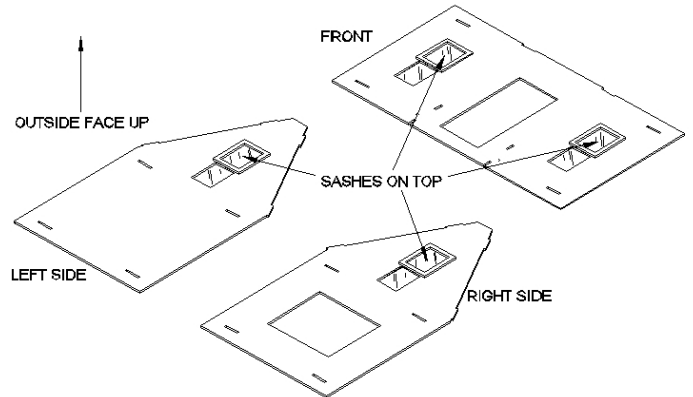

3. **R&P porch gable front (6) and dormers (3).** Lay gable and dormers **face up** and position the gable and dormer window casings (the ones with the plastic windows) centered on the window cut outs – (G). Turn gable and dormers **face down**. Using prepared interior gable and dormer casings, position the casings centered on the window cut outs – (G).

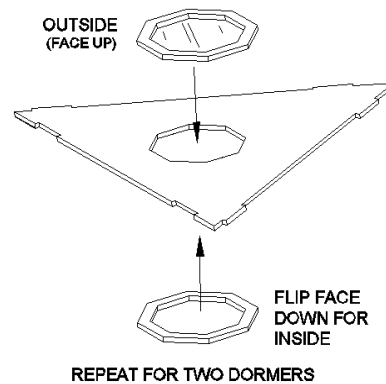

4. **R&P** window casings (3,6,7). There are eight of these. Four interior, four exterior – they are all identical. Lay the front, the left, and the right sides **face up** and position four exterior casings around the four window openings. Center the lower legs of the casings equal distance from the lower window cut out. This space forms the lower window sash – **(G)**.

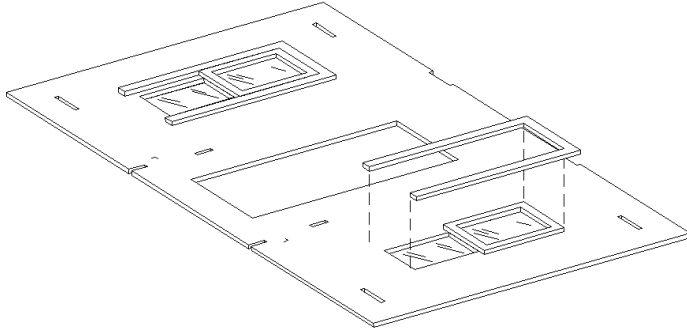

5. Turn the front and side panels **face down**. Position the remaining interior casings over the four window cut outs. Keep the lower legs of the casings level with the bottom edge of the interior window sash – **(G)**.

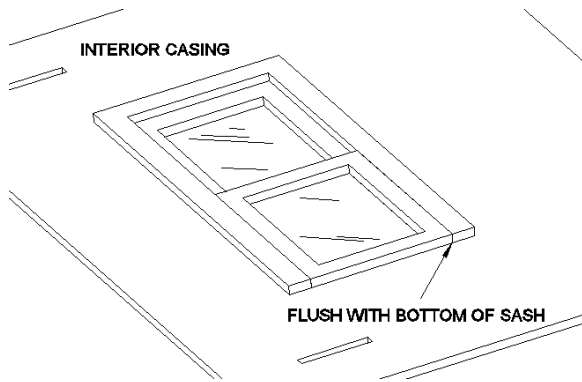

6. **R&P** the window sills (2). There are eight of these. Four interior, four exterior. They are all identical. Lay the front, left and right side panels **face down**. Position four interior sills on edge, under and centered on the interior window casings – **(G)**. Turn the front and side panels **face up**. Position the remaining four sills on edge under and centered on the exterior window casings – **(G)**.

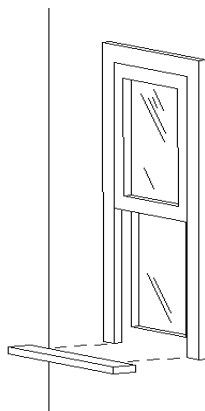

7. **R&P** the window casing bottoms (2). There are four of these – all exterior. Position the casing bottoms under and centered on the window sills – **(G)**.

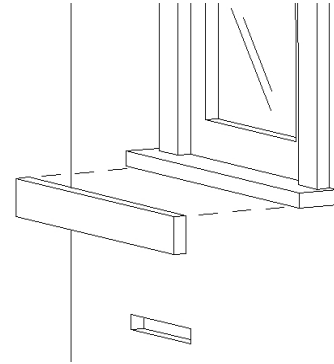

8. **R&P** the window corner blocks (4,5). There are ten of these. Eight are required, and there are two extra. **R&P** the double hung window pediments (7,9) and pediment caps (6). Position each corner block on the lower legs of the window casings, resting on sills – **(G)**.

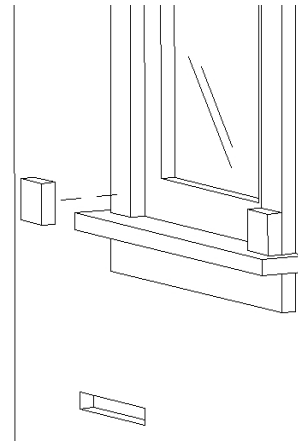

Position pediment caps on the window pediments, top edges flush – **(G)**.

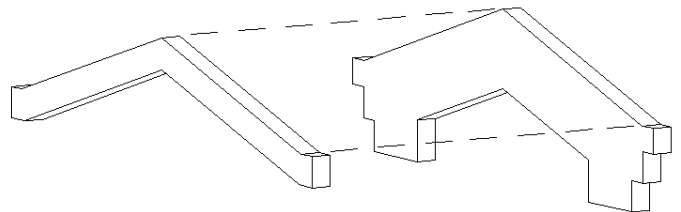

9. Position prepared pediments on top section of window casing. Be sure pediments are positioned the same on all four window casings – **(G)**.
NOTE: Front door casings, interior and exterior, will be assembled at a later point.

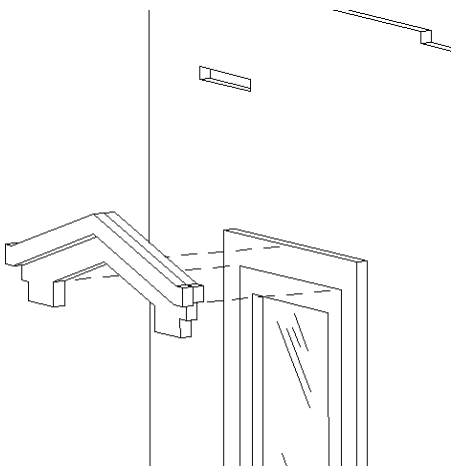

- Use prepared left and right side panels. Right side has large rectangular opening for bay window. Insert the left side tabs on first and second floors into appropriate slots in left side – (G). Assemble right side in same manner – (G). Edge of sides butting to front should receive glue as well.

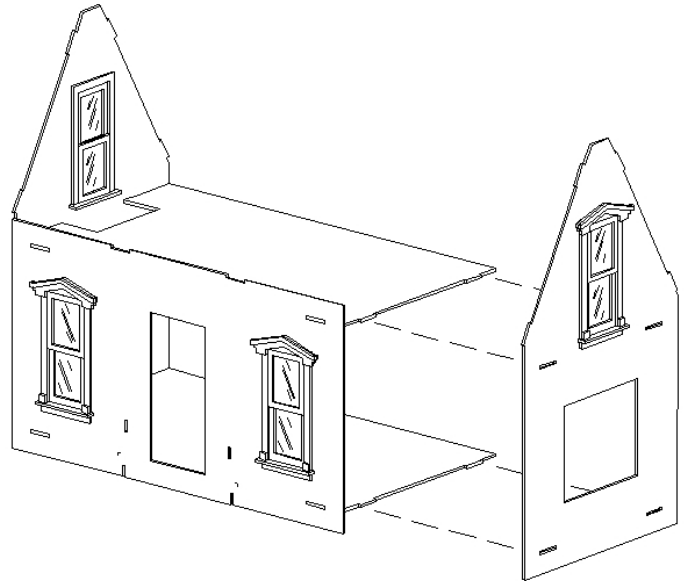

C) ASSEMBLY OF HOUSE STRUCTURE

- R&P first floor (1).** Use prepared front. Insert front tabs on first floor into first floor slots in front. Be sure floor is flush with bottom of front door opening – (G).

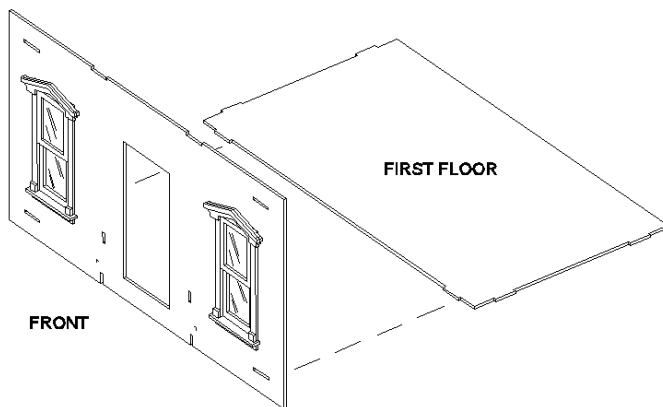

- R&P two front door casings (6).** One is interior, one is exterior. Position interior front door casing around front door opening – (G). Exterior casing will be used at a later point.



- R&P second floor (2).** Insert front tabs on second floor into second floor slots in front – (G).

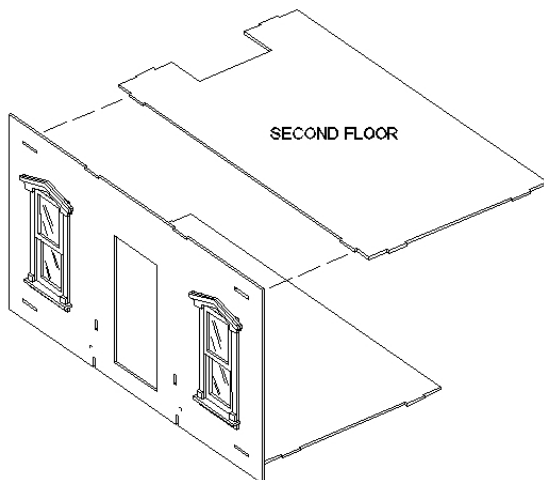

- R&P attic partition and first floor partition (7).** These items are not tabbed and can be placed wherever you wish. However, before gluing attic partition in place, fit the front roof to the tabs on the sides and note where the dormer cutouts are. Mark with a pencil and then position the attic partition accordingly. Remove front roof and proceed – (G).

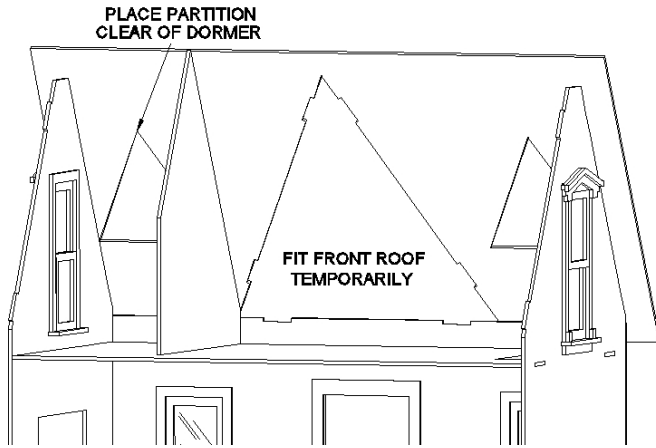

6. **R&P front roof (6)**. Position left and right side slots over roof tabs on sides – **(G)**. Short edge of attic partition butting front roof should receive glue as well.

of attic partition should receive glue as well.



- Using two gussets, position one gusset on each side, under roof at apex. This covers the triangular opening – **(G)**.

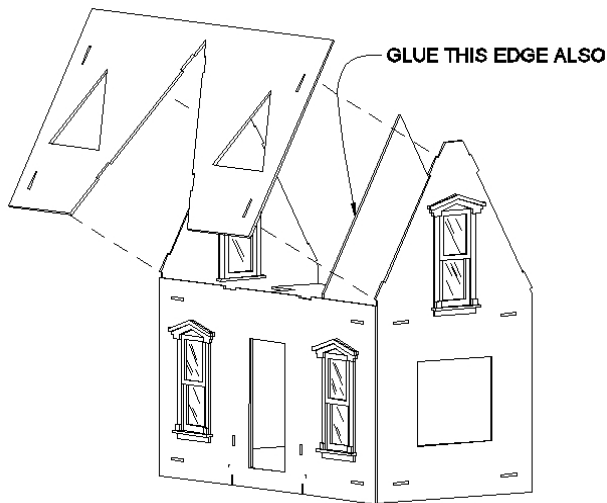

7. **R&P all gussets (3,5)**. There are 6 in all. Refer to illustration and position one gusset against inside edge of front roof, near the middle but not in gable cut out – **(G)**. Set aside remaining gussets.

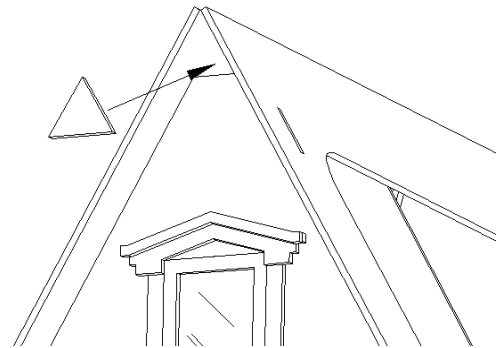

9. **R&P first floor base piece (1)**. Position under first floor at rear of house. Position it flush with side edges and first floor edge – **(G)**.

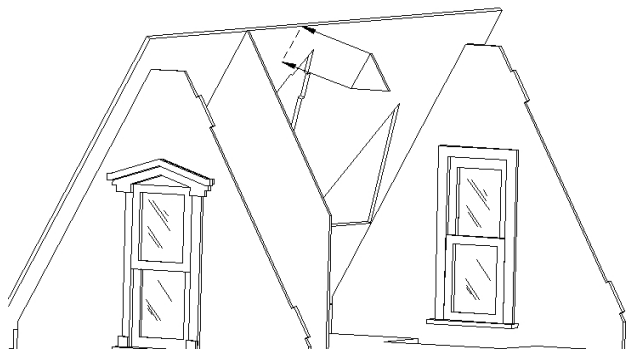

8. **R&P rear roof (7)**. Position left and right side slots over roof tabs on sides – **(G)**. Edge of gusset and top portion

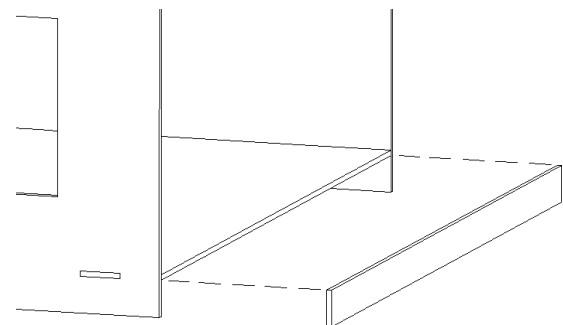

D) ASSEMBLY OF DORMERS

1. **R&P dormer roofs (4,5)**. There are two right and two left (Each dormer will get one right and one left). Use prepared dormer fronts and position left dormer slots

over dormer roof tabs – (G).

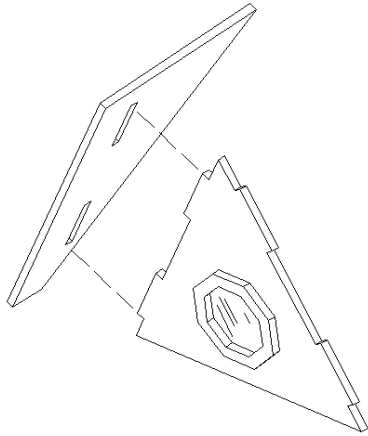

Using one gusset per dormer, position the gusset to inside of top edge of left dormer roof – (G). Position right dormer roof over dormer roof tabs and gusset – (G). Repeat for second dormer.

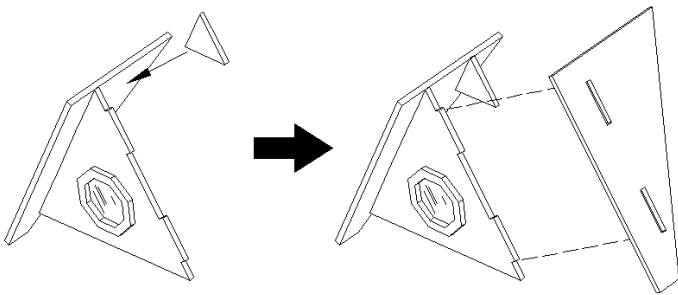

2. Position assembled dormers over dormer cut outs in front roof – (G).

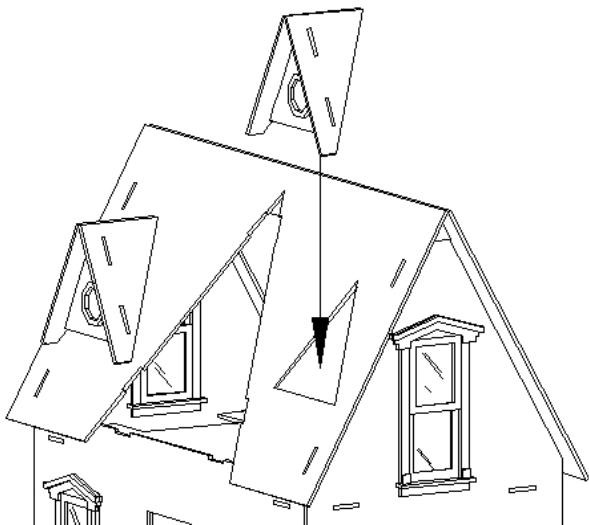

E) ASSEMBLY OF PORCH

1. R&P porch base front and sides (5). Butt the two side pieces to the back of the front piece – (G). Position base side tabs into porch base slots on the front of house – (G).

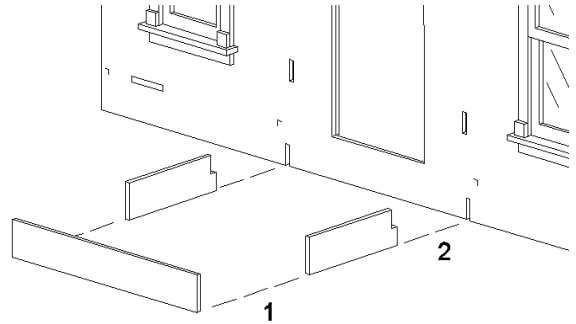

2. R&P porch front and side risers (5). Butt sides to back of front – (G). Position riser unit to porch front base – (G).

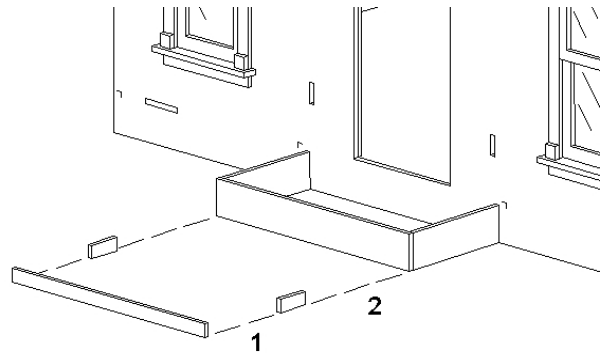

3. R&P porch floor (1) and stair tread (5). Position porch floor resting on porch base and against the front of the house, centering on corner notches embossed on front – (G). Position porch stair tread on stair tread riser and centered with porch floor – (G).

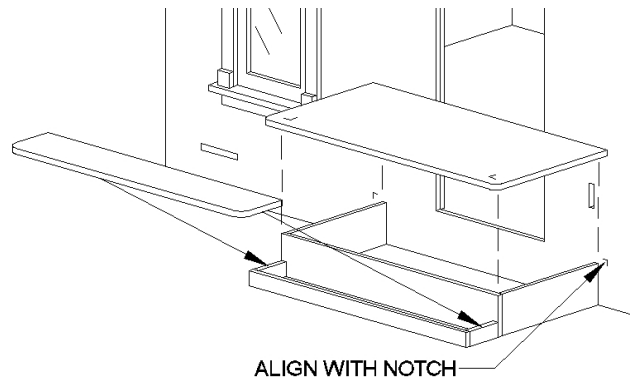

4. Position prepared exterior front door casing around and flush with front door opening in front – (G).

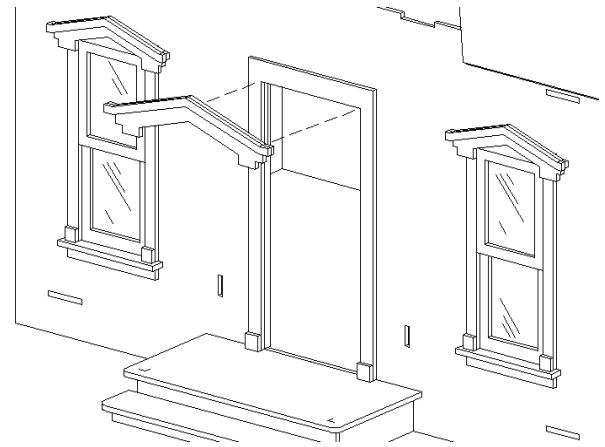
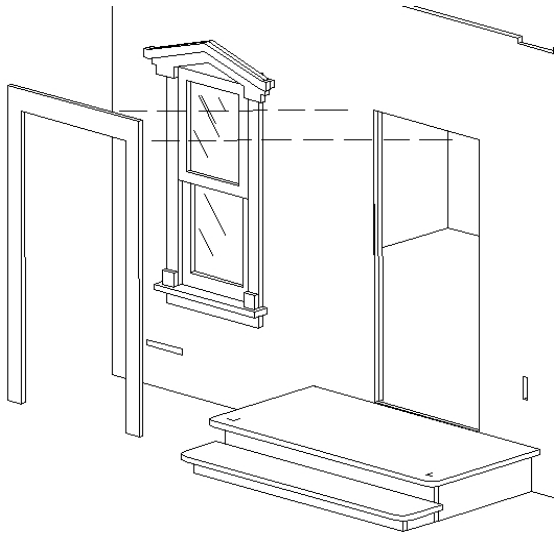

6. Previously assembled front door can now be hinged to door casing or glued in position.

5. **R&P** front door corner blocks (4). Three are provided – two are used. **R&P** front door pediment (2). **R&P** front door pediment cap (6). Position corner blocks on bottom of front door exterior casing, resting on porch floor – (G).

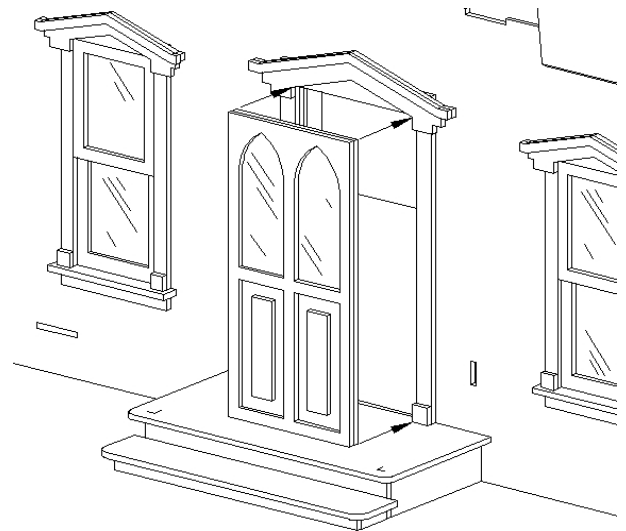
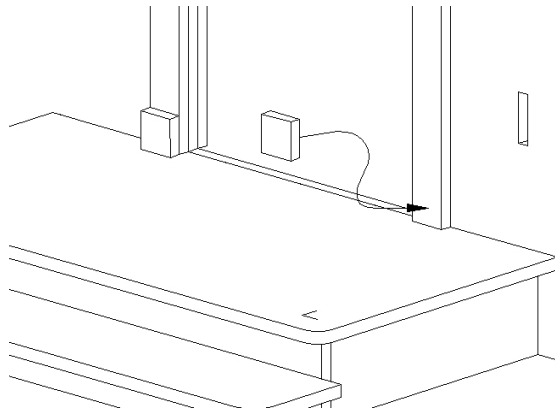

7. **R&P** porch railings (2). Position railing tabs into slots in front of house and center front leg of railing on notches embossed on porch floor. Smooth side of railing should face outward – (G).

Position front door pediment cap over front door pediment with top edges flush – (G). Position pediment on top of front door casing – (G).

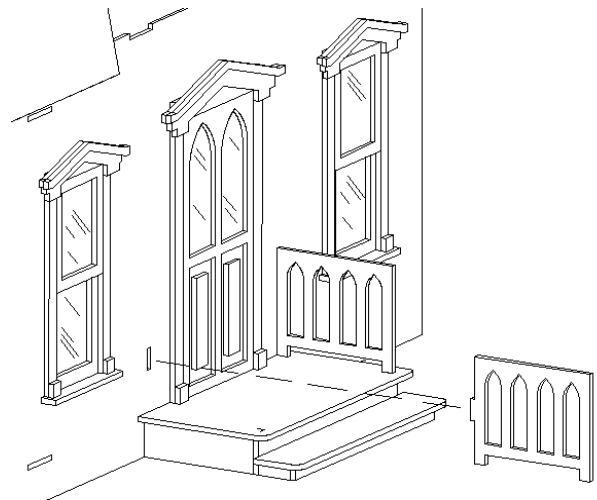
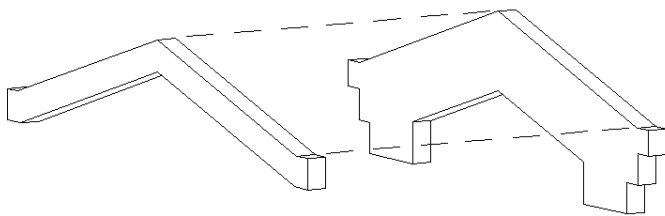

8. **R&P** porch railing handrails (1) and railing posts (1). Position handrails on top edge and centered over porch railing – (G). Position railing posts against front edge of porch railing and centered under porch handrails – (G).

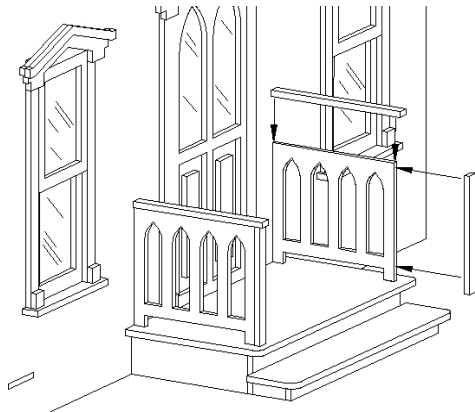

Stand porch post grillwork unit on top of porch railing handrails, set back from front edge of handrail by approximately 1/8". This measurement is not exact, just be sure that the front edge of the corner blocks are recessed back from the edge of the handrail – (G).

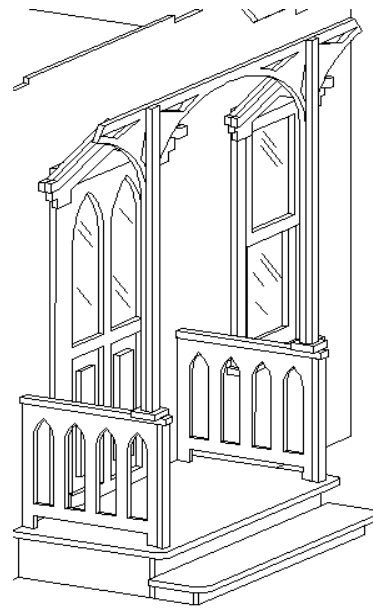

9. **R&P** porch post grillwork (8). Use extreme care when removing the grillwork parts from this sheet! **R&P** porch post corner blocks (4). Three are provided – two are used. Lay porch post grillwork face up and position porch posts over each long post part of grillwork. Be sure top and bottom ends are flush with edges of grillwork – (G).

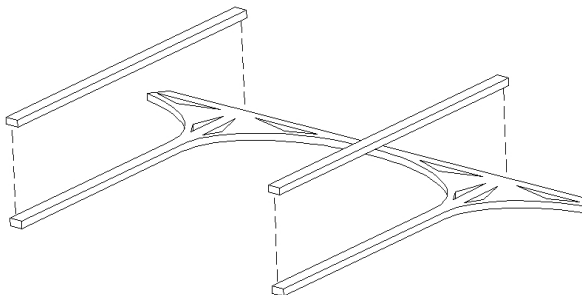

Stand porch post grillwork straight up and position one corner block centered under each porch post end – (G).

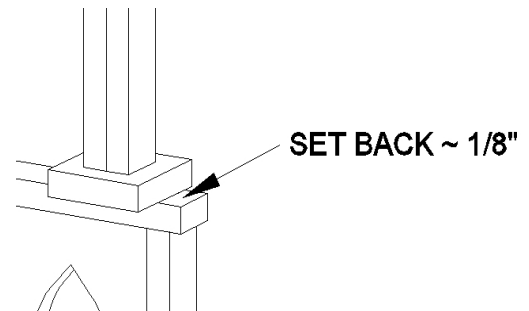
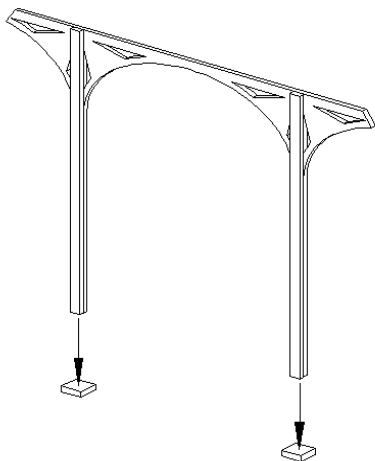

10. **R&P** porch ceiling (1). Position ceiling face down with front tabs in porch ceiling into slots in front of house. Top edge of porch posts will be flush with outer edge of gable tabs on ceiling.

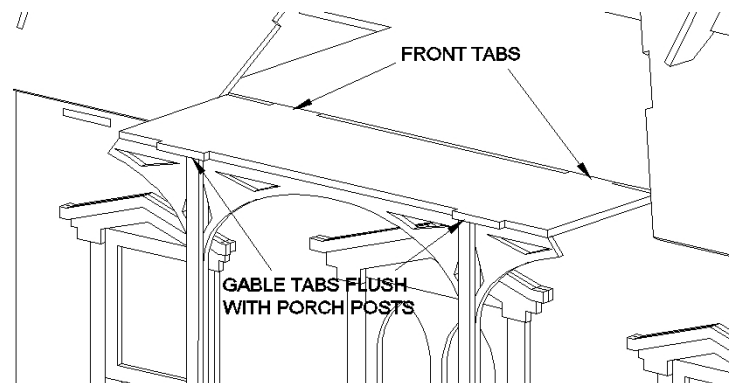

When viewed from the side, the porch posts unit will be parallel with front of house (i.e. straight up and down) – (G).

F) ASSEMBLY OF GABLE

1. R&P gable roof left (4) and right (5). Use one gusset. Position prepared porch gable with porch ceiling slots over gable tabs on ceiling – (G).

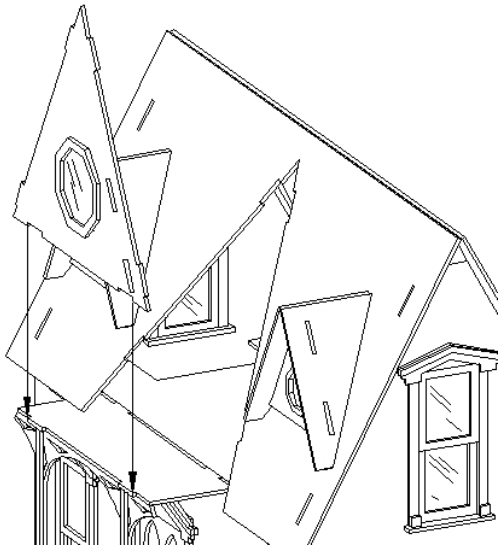

2. Position left gable roof with gable slots over roof tabs on gable and front roof tabs in left gable roof slots in front roof – (G). Position one gusset against inside of left gable roof – (G). Position right gable roof on roof tabs of gable and roof tabs in slots of front roof – (G). Apply glue to gusset as well.

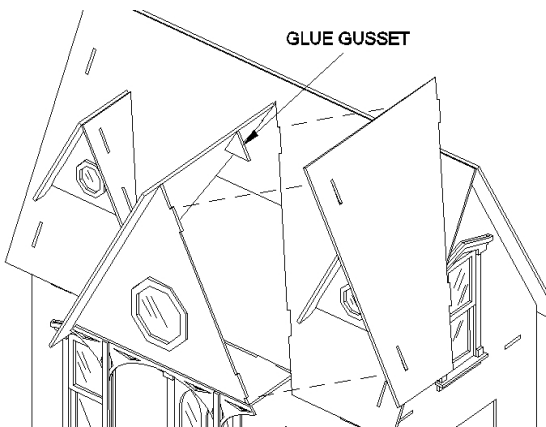

G) ASSEMBLY OF STAIRS

1. R&P stair stringers (9) and stair treads (1,2,3). There are two stringers and nine treads. Note the small notch in one end of stringers denotes the TOP.

NOTCH IN TOP

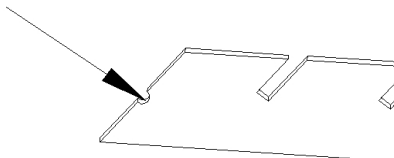

Lay one stair stringer **face up**. Position one stair tread into slot at opposite ends of stringer. Keep treads at 90° to stringer. Smooth sides of treads should face the TOP of the stringer – (G).

2. Position second stringer **face up** – notch towards TOP – over tabs of first and last stair tread – (G).

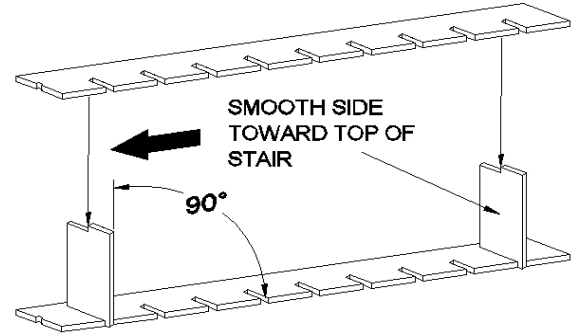

Remaining treads are now inserted and glued into remaining slots in both stringers. It is important to keep everything as “square” as possible while assembling.

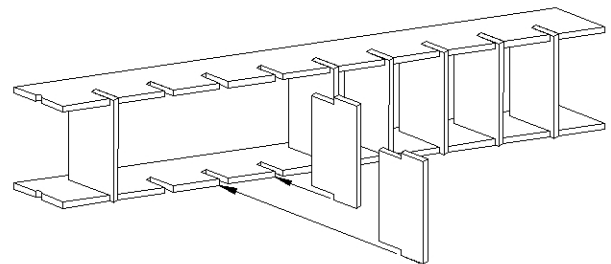

3. Position stair unit in house with top against bottom of second floor near edge of opening.

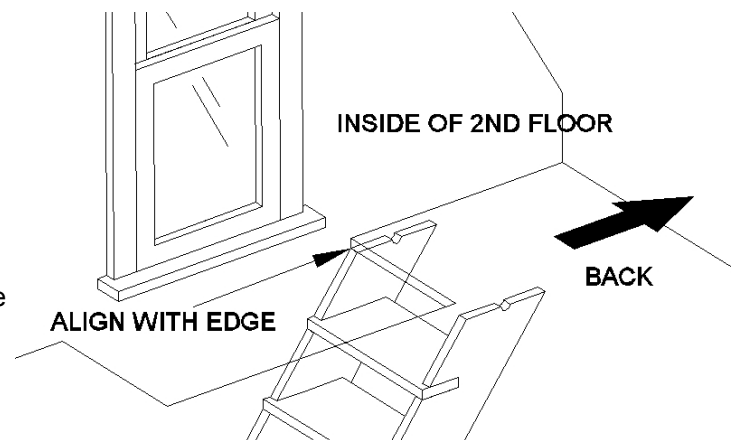

Bottom rests on first floor with side of stringer resting against left wall of house. Bottom of stairs should be at front of house – (G).

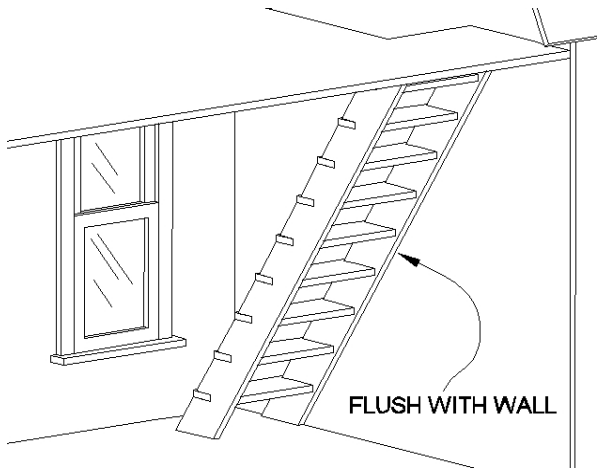

All recessed edges on casings are toward interior.

TOP VIEW

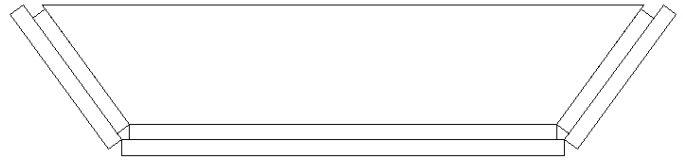

- Position assembled unit over and centered on bay window cut-out in right side of house – (G).

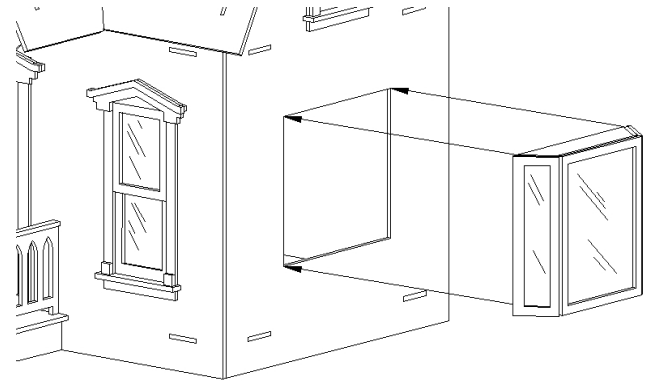

H) ASSEMBLY OF BAY WINDOW

- R&P** bay window top and bottom (3). Position prepared large (center) bay window casing **face down** (recessed edge on sides will be facing you). Position bay window top, smooth side toward window, against inside edge of interior casing, flush with top edge of casing and centered – (G). Position bay window bottom against inside edge of window casing, smooth side toward window, and flush with top edge of casing – (G).

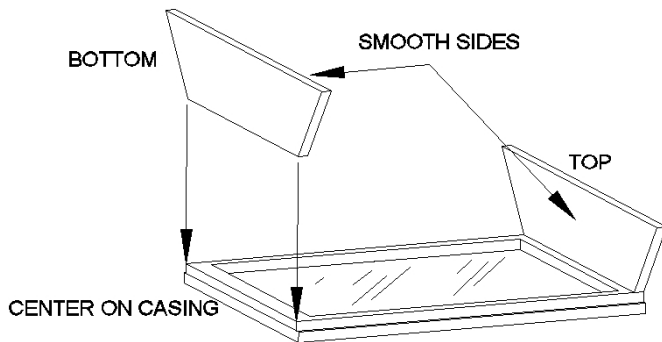

- Before **R&P** of bay window roof (4), mark each roof section as labeled in schematic (i.e. left, right, front edge). Turn sheet #4 **face down** and apply masking tape across the back of the three roof sections – in effect hinging the left and right roof to the center section. Turn sheet face up and proceed with **R&P** of roof sections. Remove as a hinged unit.

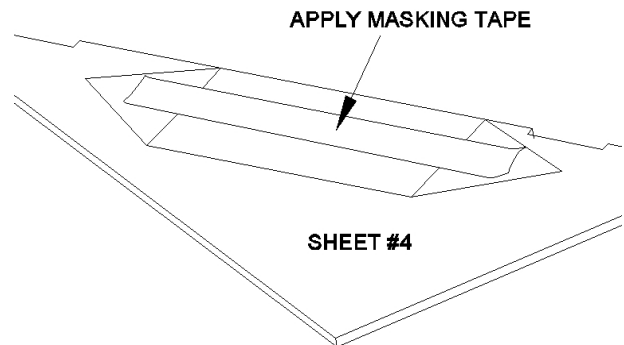

- Turn unit **face up**. Position each narrow bay window casing to either side of large casing, butting outside edge of large casing and flush with top and bottom – (G).

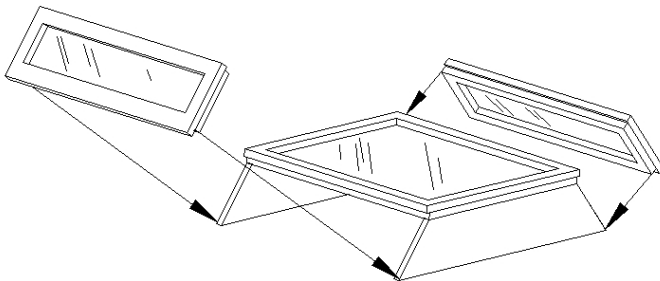

- Position the roof unit over the bay window unit with “front edge” outward. Allow the roof to “drape” itself over the unit with back edges resting evenly against right side wall and the under side resting against top of bay unit. Remove, – (G) and set back in place.

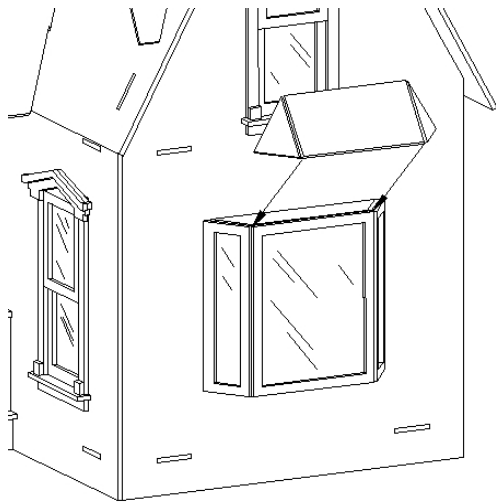

3. **R&P apex grillwork (8)**. There are three pieces – one left side, one right side, and one gable. Note that these pieces and all gingerbread pieces are recessed about 1/8" from edge of roof. Position each apex piece in the three locations under roof edges – **(G)**.

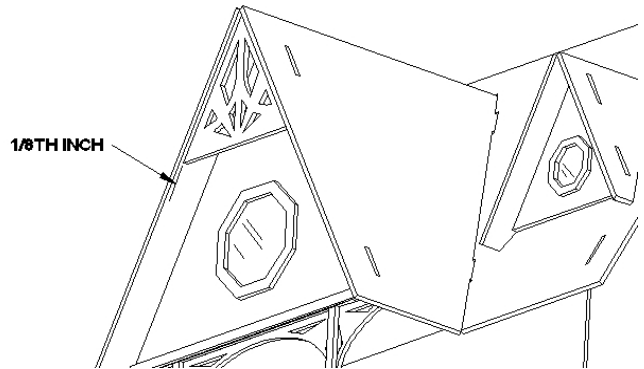

I) ASSEMBLY OF TRIM, GINGERBREAD AND EAVES

1. **R&P first slot trim (7)**. There are two side pieces and two front pieces. Position each front piece over front first floor slots and top edge of trim even with porch floor – **(G)**. Position each side piece over first floor side slots and butting up to front trim pieces – **(G)**.

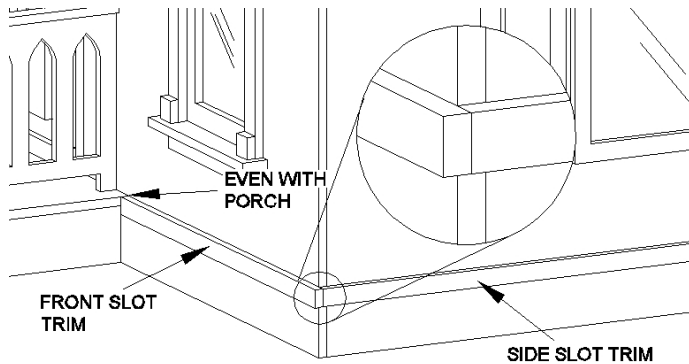

4. **R&P main roof gingerbread (8)**. There are two left, and two right pieces. Each side gets one left and one right. Position each piece, butting to bottom edge of apex piece and recessed 1/8" from roof edge – **(G)**.
5. **R&P porch gable gingerbread (8)**. Position these two pieces, left and right, as previous side pieces – **(G)**.

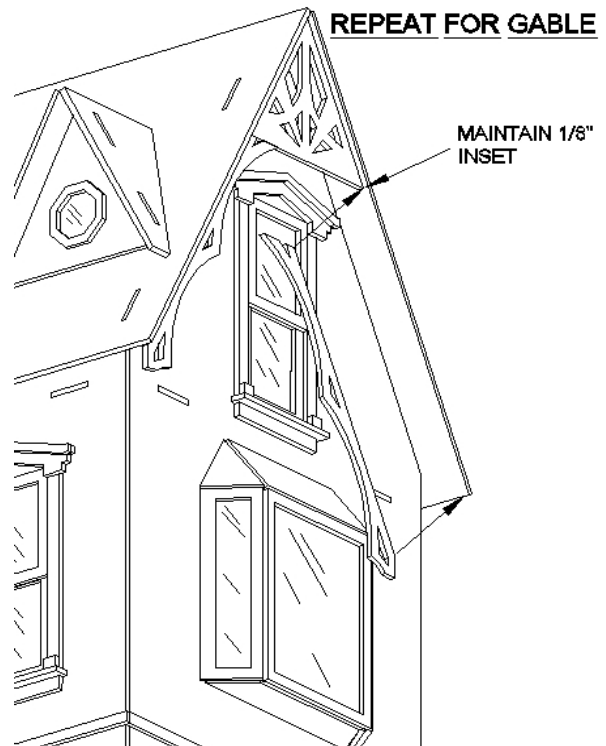

2. **R&P gable edge trim (4)**. Position trim piece so it covers ceiling tabs and slots in bottom edge of gable. Slanted ends rest against gable roof – **(G)**.

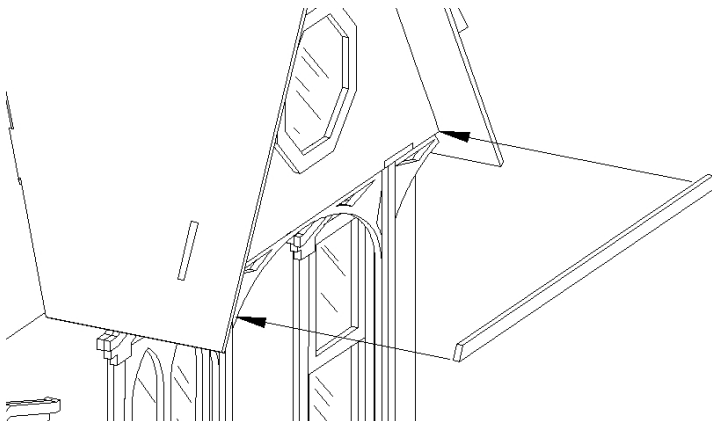

6. **R&P dormer gingerbread (8)**. Note that the left and right pieces butt together at apex of dormer. Position each piece, recessed 1/8" from roof edge – **(G)**.

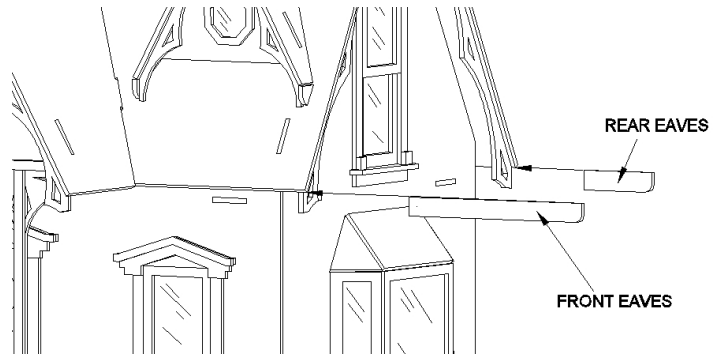
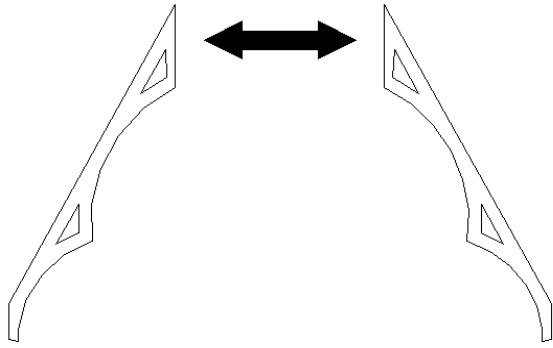

Finally, position gable eave boards in same manner to gable roof edge butting flat end to the end of front eave board – (G).

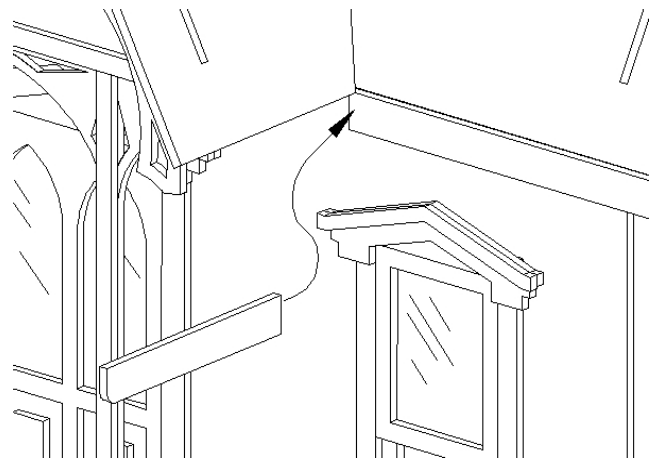
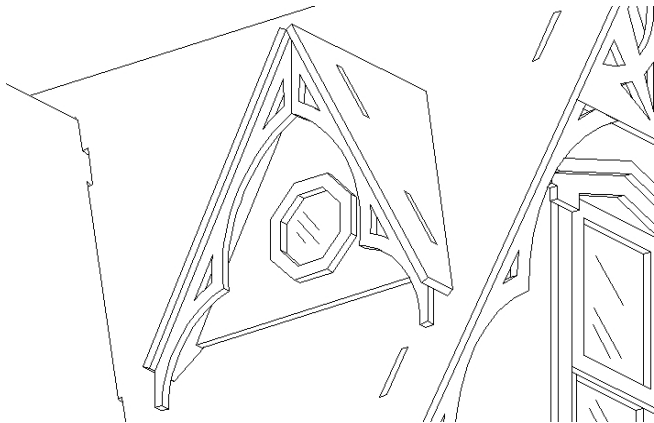

7. **R&P eaves (3)**. There are five sets of eave boards. Four dormer, two rear, two gable, and two front. Starting with the dormer eaves (the smallest), position eave boards so curved edge is to the front and bottom, flat edge butts to lower edge of dormer roof. Slanted edge rests on front roof, and inside surface rests against lower edge of gingerbread – (G).

8. **R&P roof ridge trim (10)**. There are five pieces. One gable, one for each dormer, and two main roof pieces. Note that the main roof pieces butt together in the center of the roof. Position one main roof ridge trim piece in valley created by junction of front and rear roof, outer edge of trim flush with outer edge of roof – (G). Position other half of main roof ridge trim on other half of roof, flush with edge, butting first piece in the center of the roof – (G).

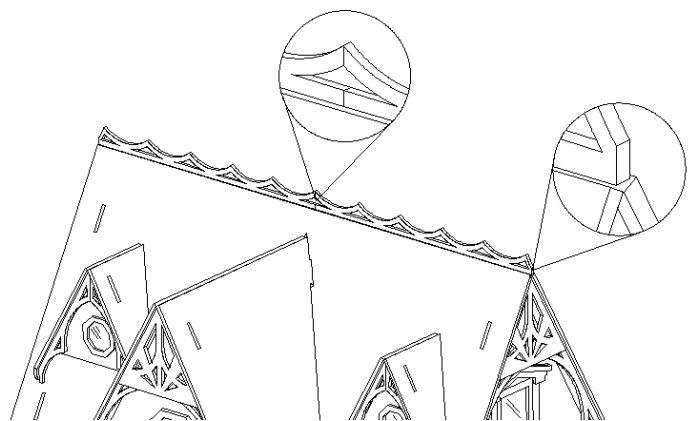
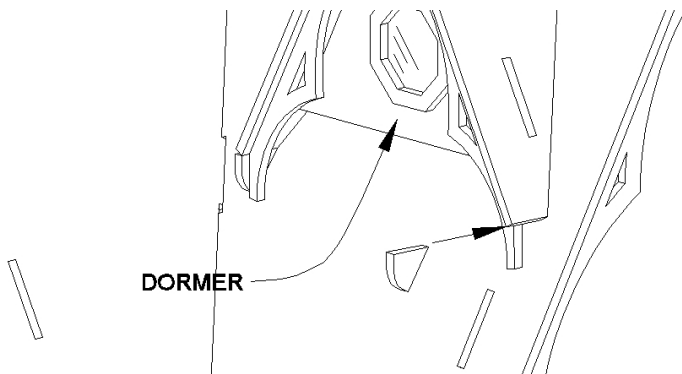

Position rear eaves against lower edge of rear roof, curved edge outward, and resting against lower edge of gingerbread – (G). Position front eaves in similar manner against bottom edge of front roof, curved ends outward – (G).

Position each dormer ridge trim on top of dormers, slanted edge resting against main roof of house – (G). Position gable ridge trim in same manner to top of porch gable roof – (G).

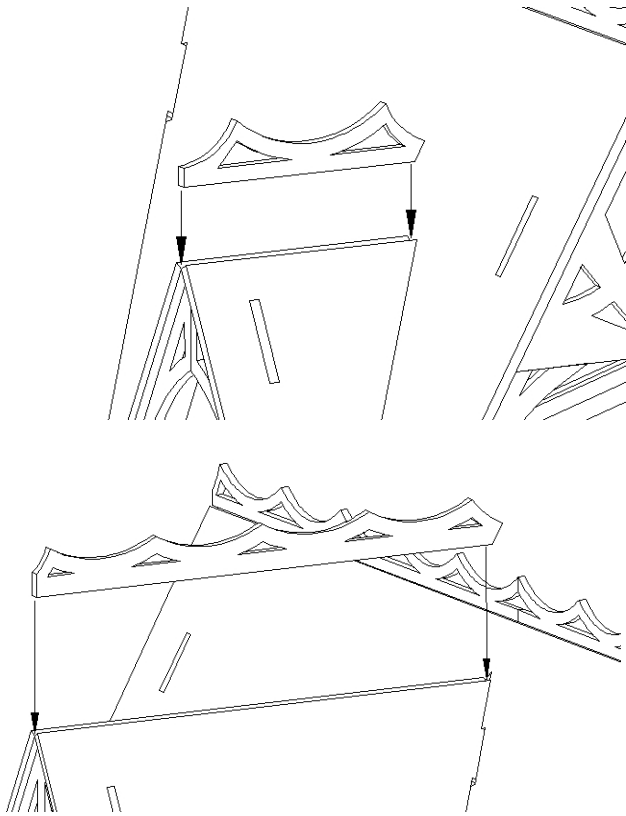

9. **R&P roof finals (6,7,10).** There are five of these. One gable, two dormer, and one left and one right for main roof. Position each final over the end of each roof ridge trim piece. The lower legs of each final resting on each roof surface – (G).

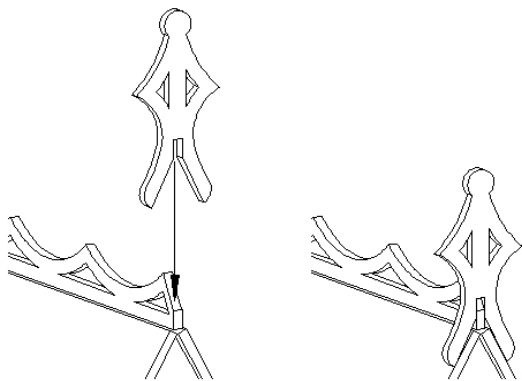

TYPICAL FINALS PLACEMENT

J) ASSEMBLY OF STAIR RAILING AND HANDRAILS

1. **R&P stair railing (11).** Position small stair railing with bottom edge even with second floor opening opposite of top of stairs. One edge should be flush against the inside of the left wall – (G). Position larger railing with bottom edge even with stair opening. Inside of smaller railing should butt against larger railing. - (G).

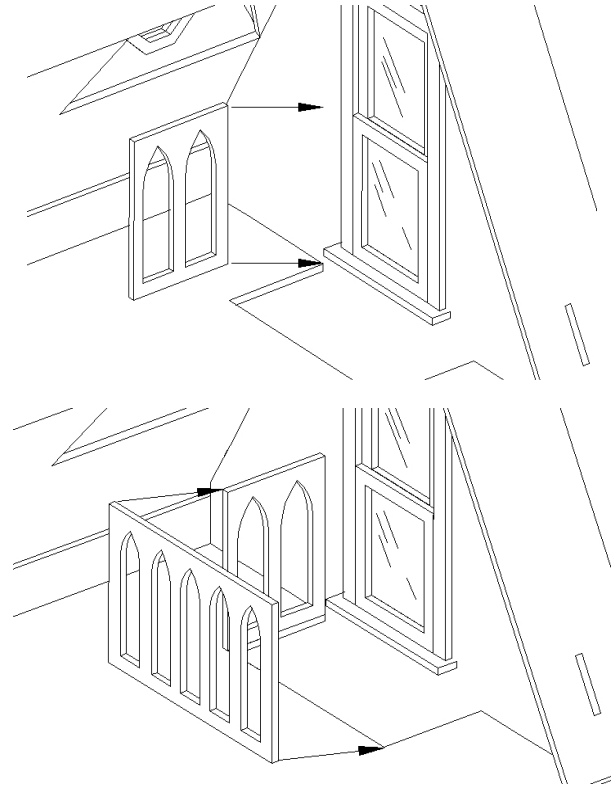

2. **R&P stair railing handrails (11).** Position smaller handrail centered on top of smaller railing with one end butting against the inside of the left interior wall. - (G). Position longer handrail centered over longer railing with curved end towards stair end of opening. Smaller handrail should butt against the inside of the larger handrail with the square end flush at the corner. - (G).

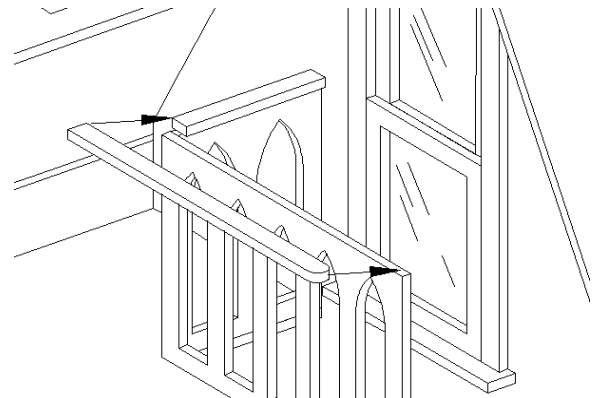

Shingles, shingles, shingles

TOOLS REQUIRED

- ◆ Sharp utility knife
- ◆ Hot melt glue gun and glue
- ◆ Pencil and ruler or other straight edge

OPTIONAL

- ◆ 1" Foam brush
- ◆ Wood stain

GENERAL INSTRUCTIONS

3. Carefully measure and draw parallel guidelines on the roof panels beginning at the bottom edge of the roof. Guidelines should be spaced apart no less than one half the length of one shingle.
4. Guidelines MUST meet evenly at all gable intersections.

**Different shingle styles are available
at your local craft store.**

5. Begin applying the top edge of the shingles along the guidelines using hot melt glue. Start at bottom edge of roof and continue upwards to top edge of roof. Shingles at each end of the row will need to be cut to size. Be sure to cut and fit each shingle at the gable intersection before gluing in place. Also keep in mind that as you continue upwards, each row should be staggered by half the width of one shingle.
6. The last row of shingles at the top of the edge of the roof will need to be trimmed in length. They should be cut to approximately half the length of one shingle and applied, giving the roof a finished appearance.
7. **OPTIONAL:** Apply wood stain with foam brush using caution not to soak the shingles too heavily as the stain may cause the glue to loosen. If this should happen, just allow the glue to re-harden on its own. (NOTE: You may want to consider staining a few extra shingles in case any are ever damaged.)

THATS IT! SIT BACK AND ADMIRE YOUR CREATION!

©2008 Corona Concepts
Schenevus, NY 12155

www.corona-concepts.com

All rights reserved

These instructions were
printed in New York State

Illustrations provided by

Ben Anderson

ben@greenleafdollhouses.com

Corona Concepts is a member of
the Greenleaf Dollhouses Family



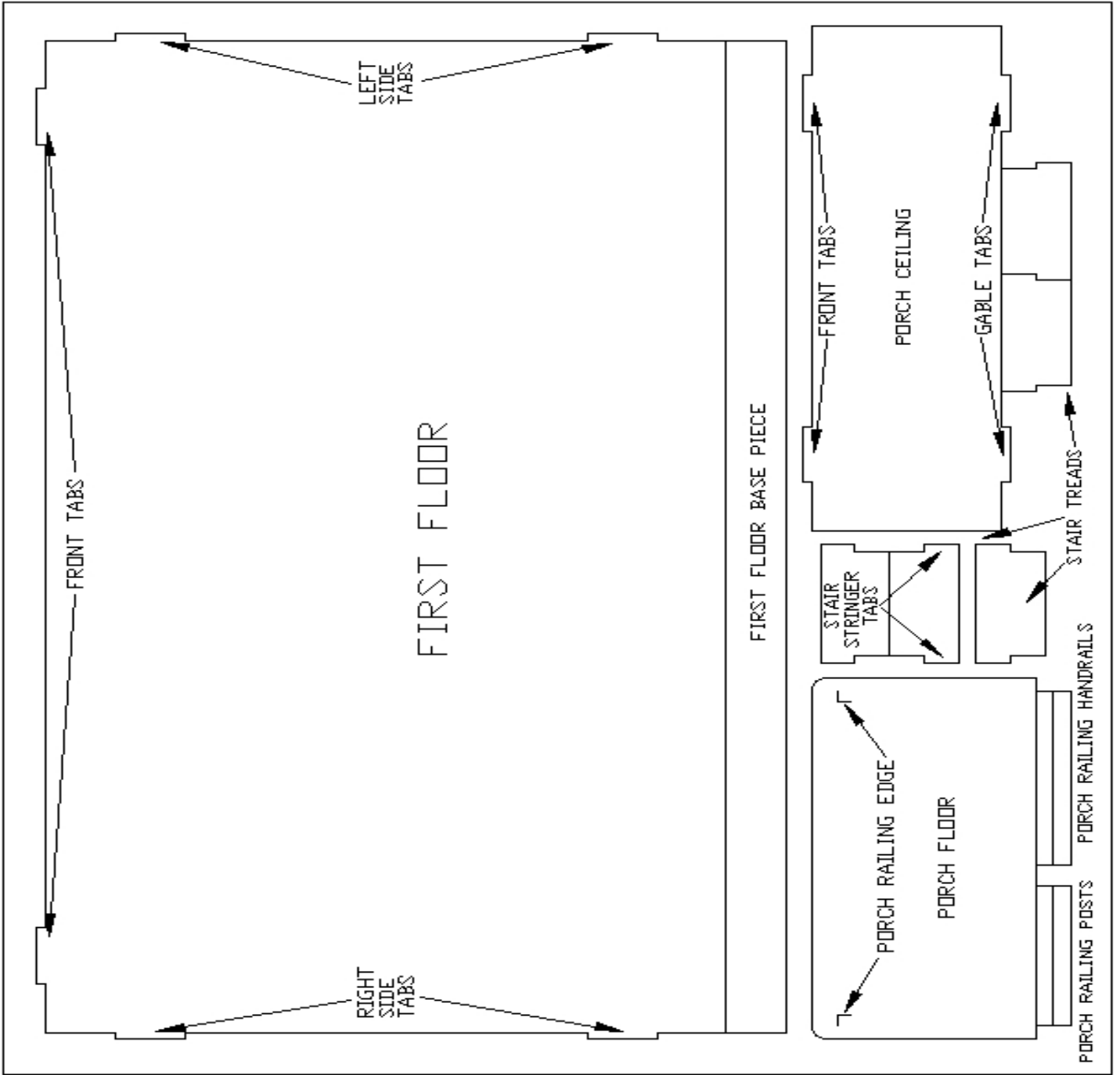

SHT 1

X

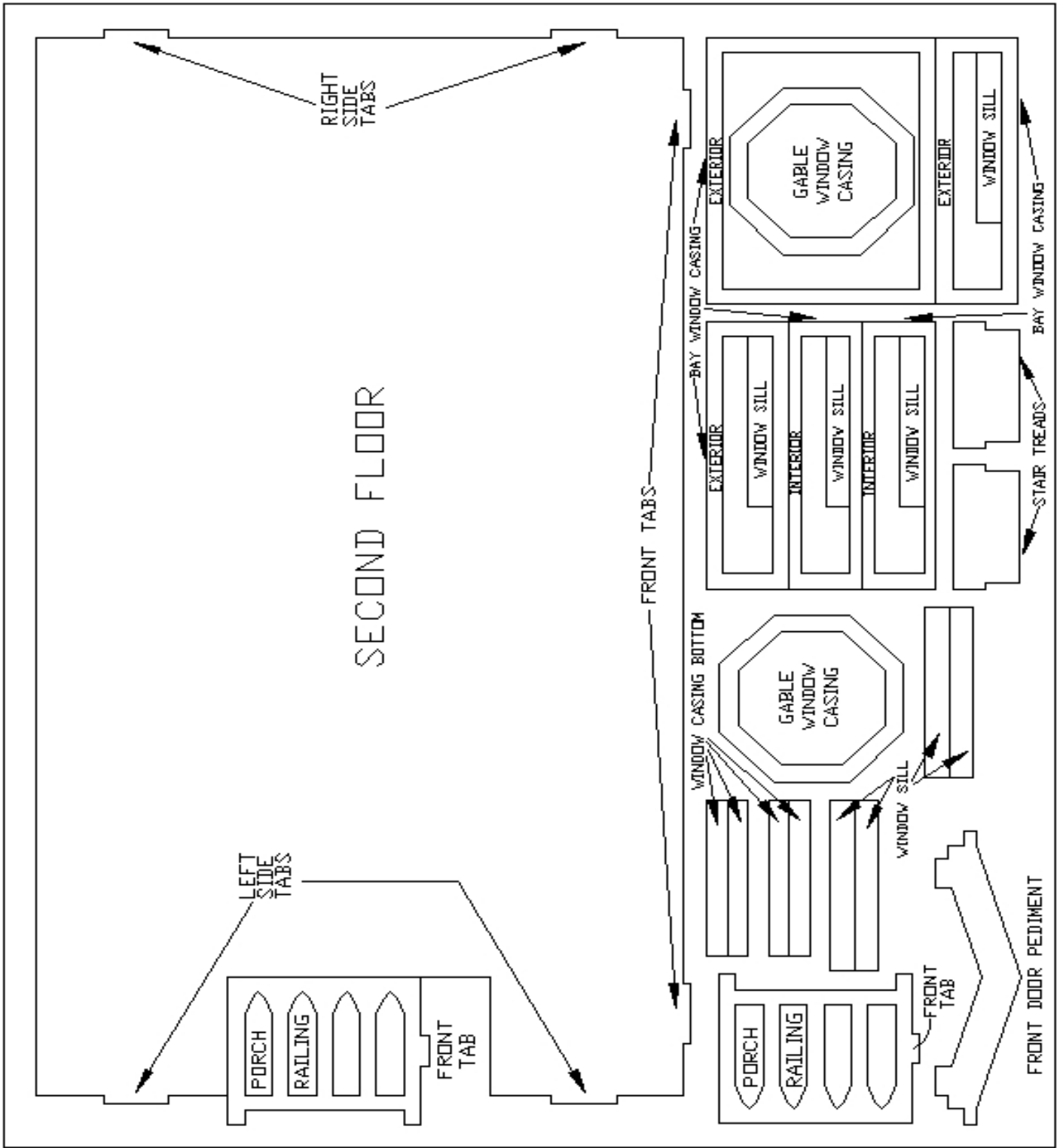

SHT 2

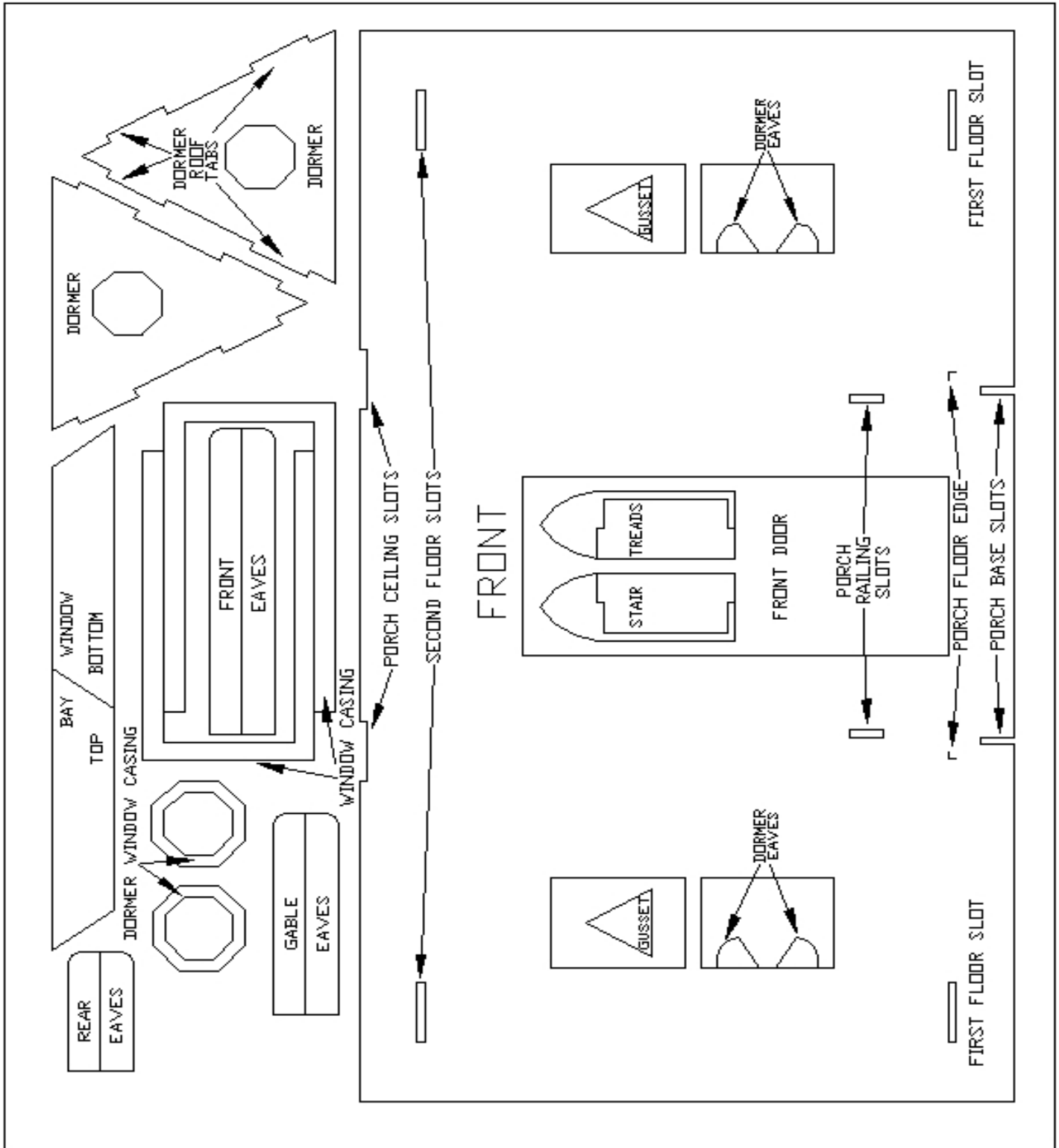

SHT 3

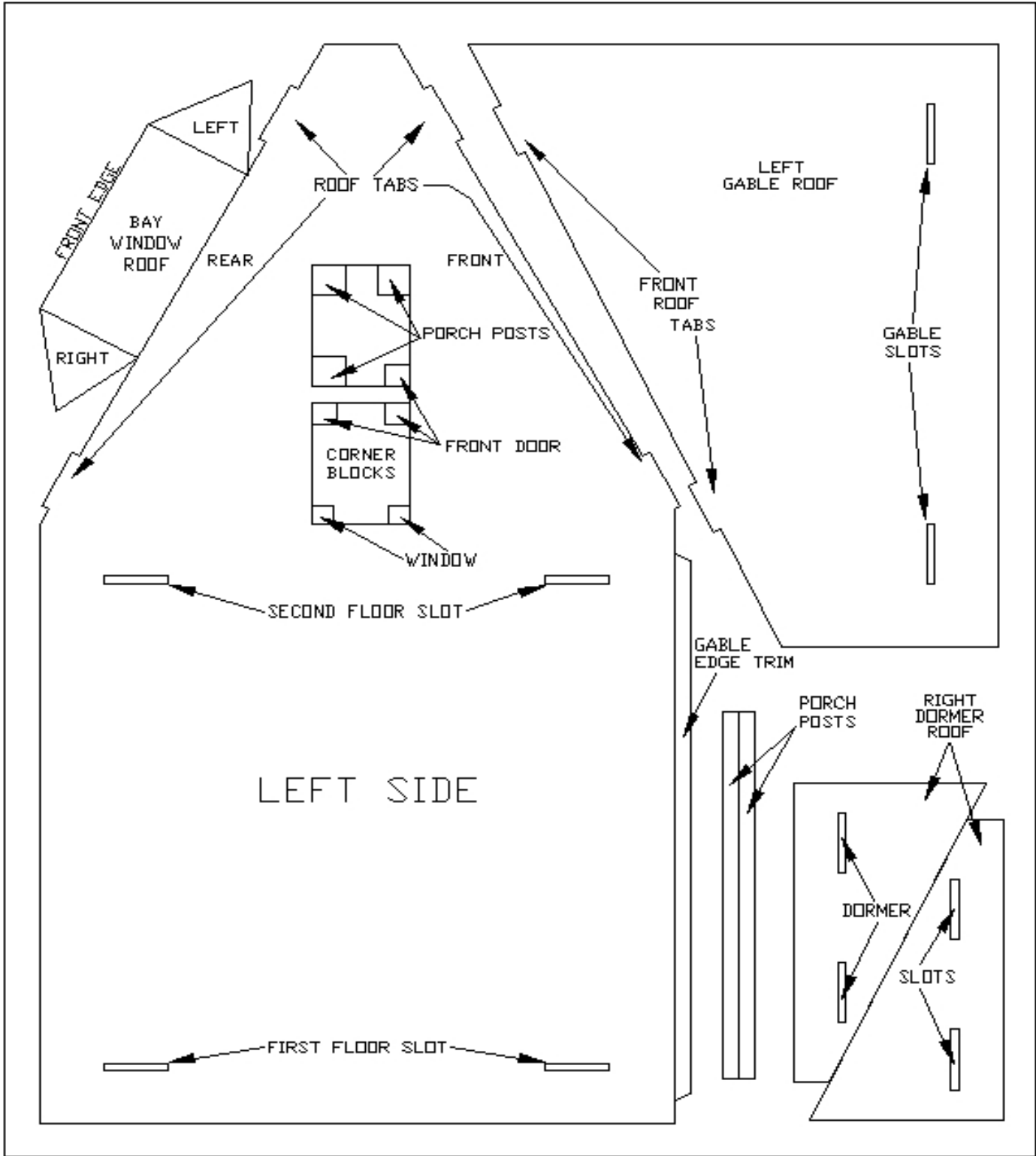

SHT 4

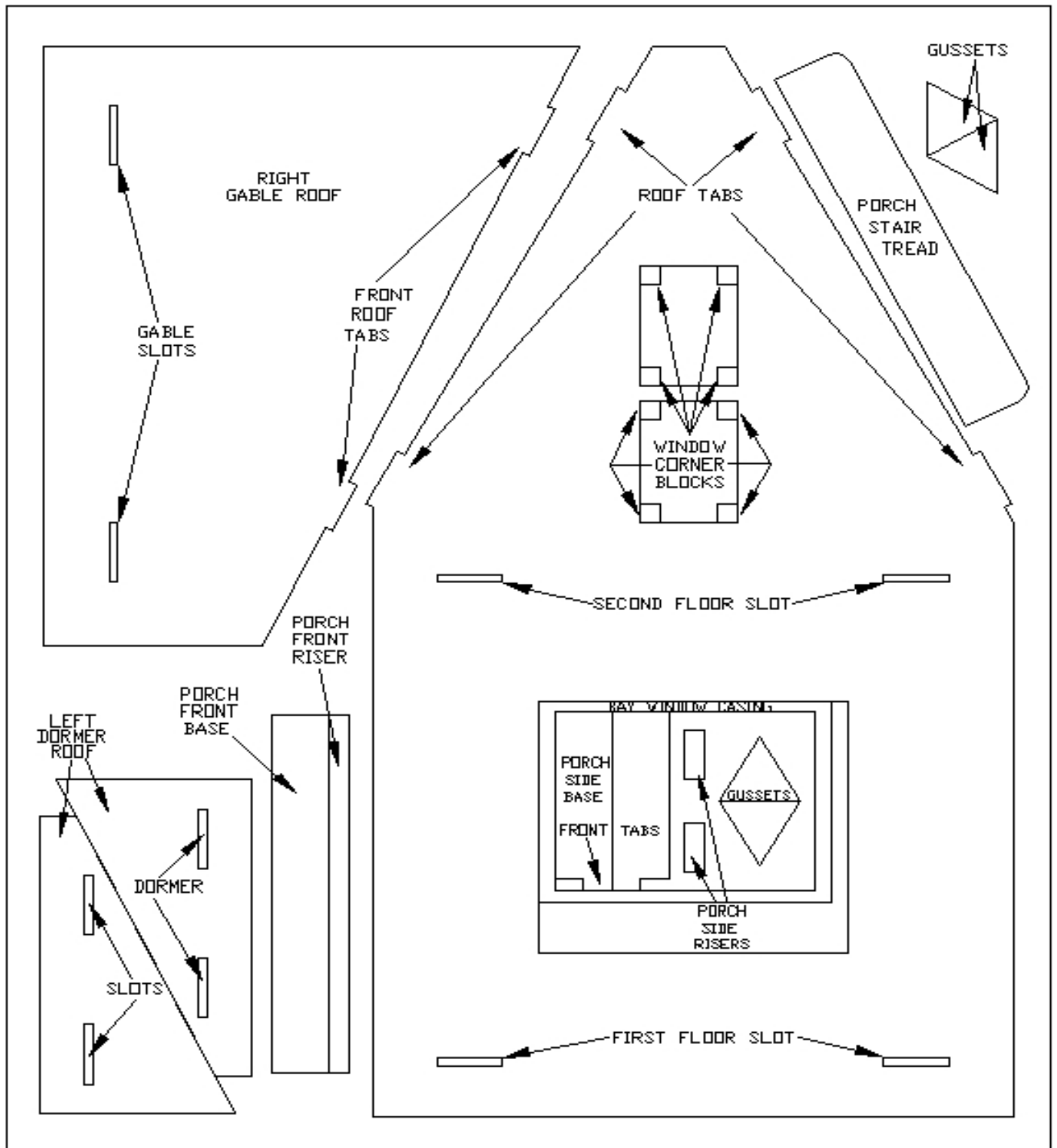

SHT 5

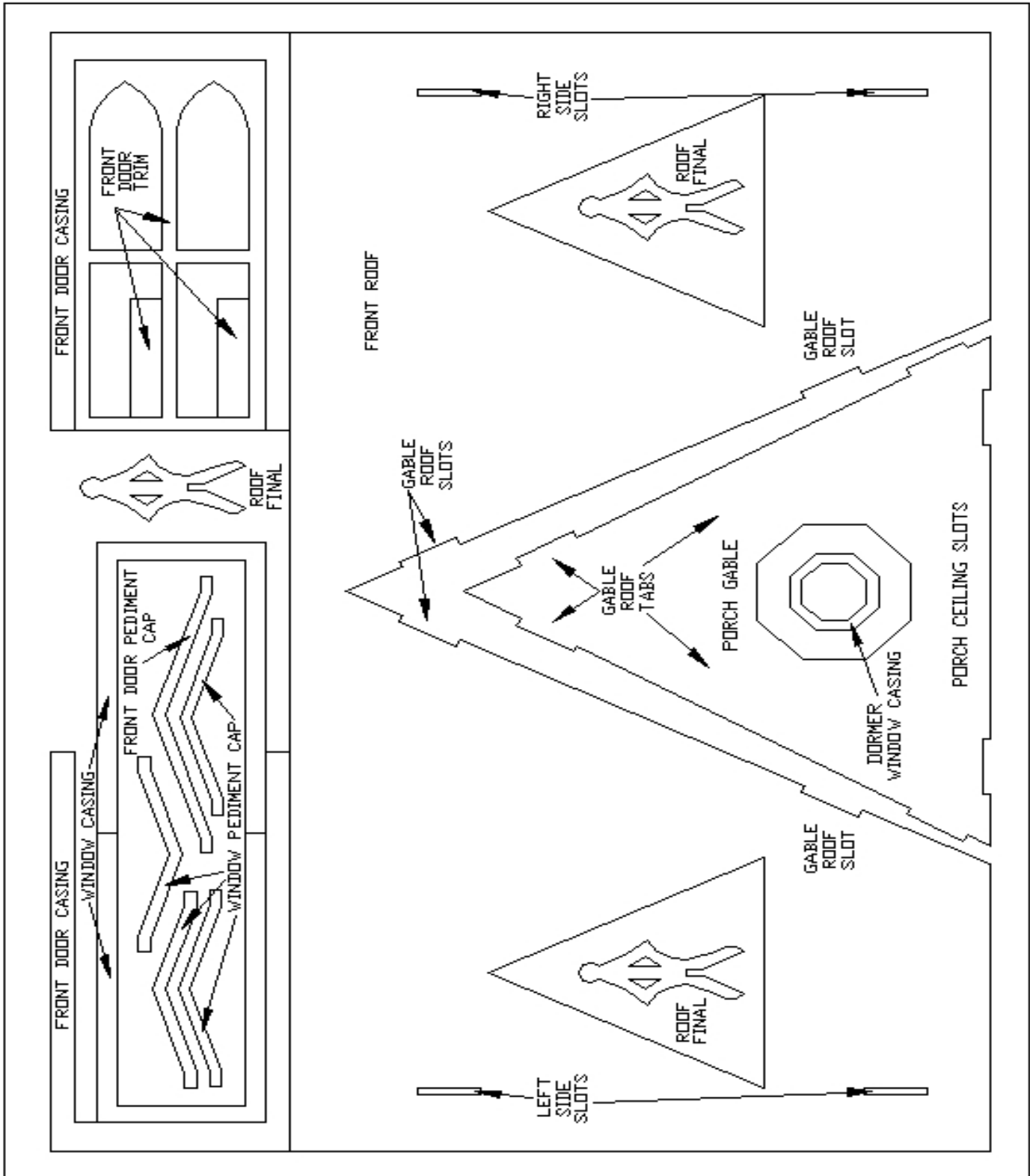

SHT 6

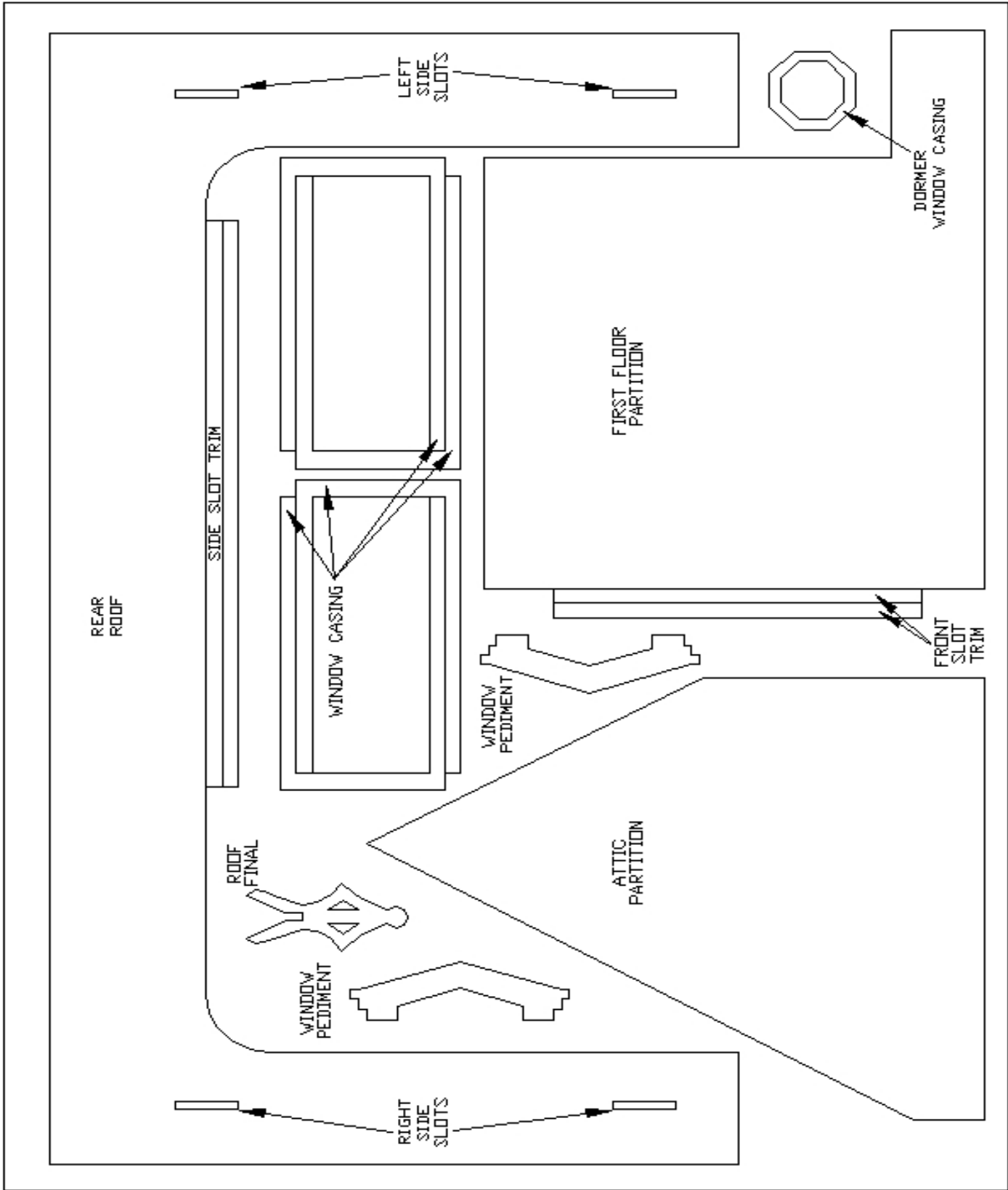

SHT 7

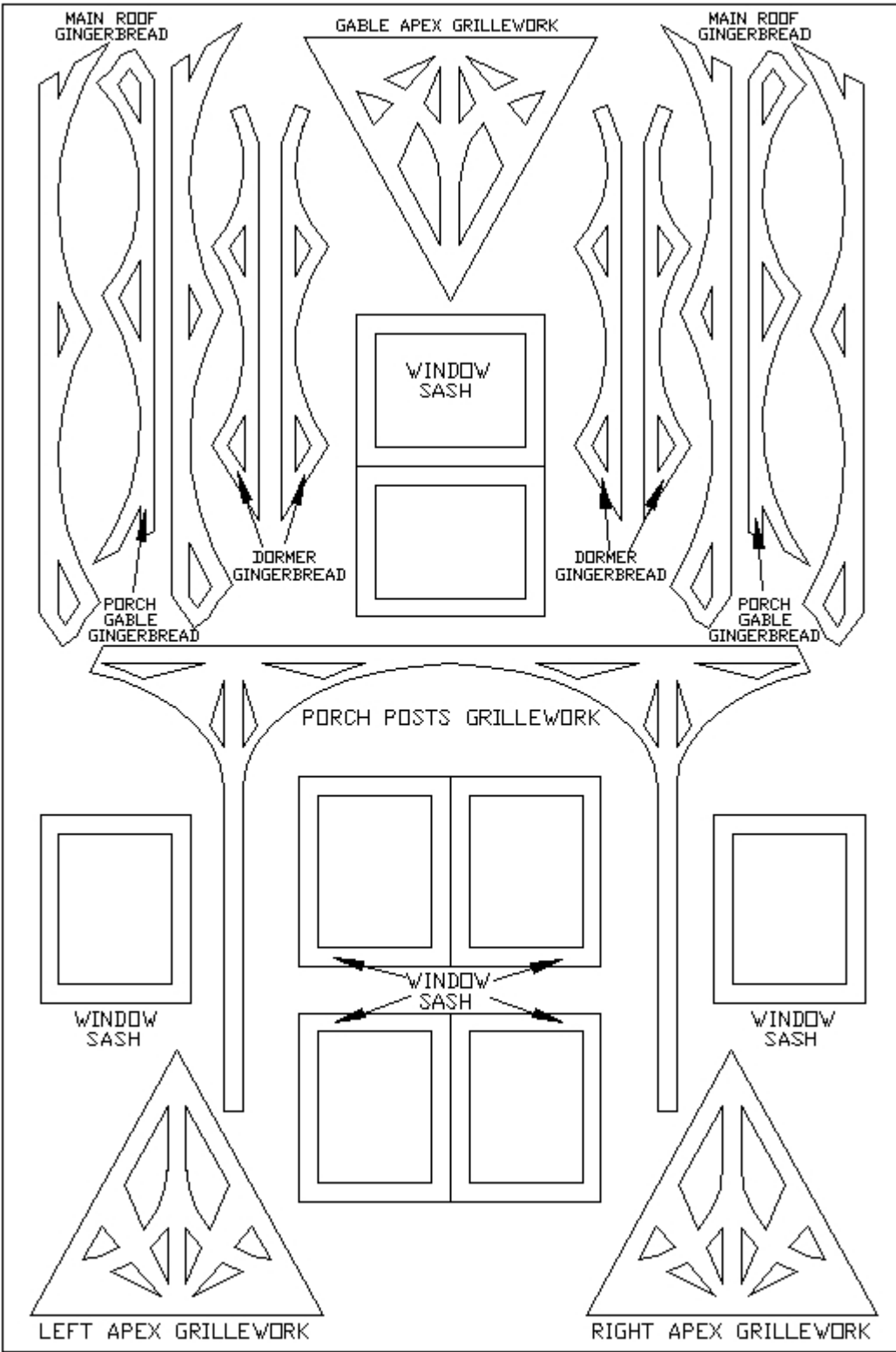

SHT 8

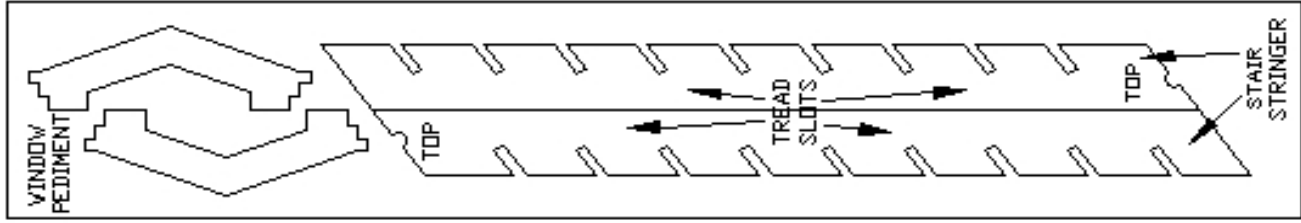

SHT 9

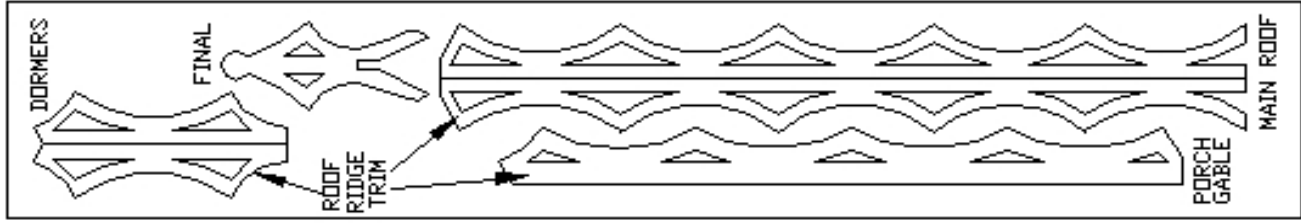

SHT 10

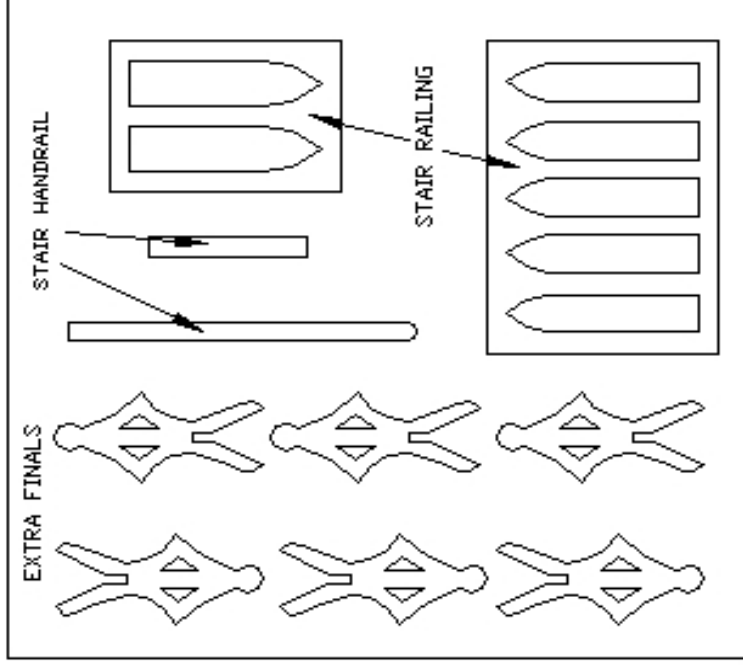

SHT 11