

MAILBOX CLASSIC POST ASSEMBLY INSTRUCTIONS

Before installing your classic mailbox post, consult your local branch of the US post office for road setback requirement and height from roadbed or curb. Post is designed for a 40" average height from ground to base of mailbox.

A - Mailbox - 1 (Sold Separately)

B - 40" Classic Post - 1

C - 1/4" Lag Bolts - 2

D - Tube of Silicon Sealer - 1

- 1) Purchase a 4" x 4" x 48" piece of treated lumber from your local lumber yard or home center.
- 2) From post office recommended road setback line add 9" and mark position on ground for front edge of post. (See Figure 1)
- 3) Place the 4" x 4" post into the hole so that the face of the post is at the marked line (See step 2) leaving at least 18" out of the ground. (See Figure 2)
- 4) Partially backfill the hole around the post. Use a level make sure the post is vertical then complete the back fill of the post hole packing the earth firmly. Recheck for vertical and adjust if necessary, then repack soil. *Note: For a more permanent installation you may use concrete mix to backfill the hole unless it is against local post office or county road commission guidelines.*
- 5) Carefully remove the aluminum post (B) from the plastic sleeve. To prevent a reaction between the treated wood and aluminum, first slide the plastic sleeve over the partially buried 4x4 and then slide the post down so that the two bolt holes are positioned away from the road and the aluminum post is resting on the ground. (See Figure 2)
- 6) Plumb the aluminum post to vertical and use 2 - 1/4" x 2" lag bolts provided (C) to secure aluminum post to treated post. (See Figure 2 - drilling pilot holes in the wood may be necessary)
Please Note: Apply small amount of Silicon Sealer (D) in and around holes before securing the two bolts to the post.

Attaching your mailbox to the classic post:

- 1) Apply a small amount of Silicon Sealer (D) around the inside and outside of the center mounting hole of your Mailbox. (See Figure 3)
- 2) Set mailbox onto the post, positioning the locators on the base of the mailbox **INSIDE** the post.
- 3) Reach inside the mailbox and place the large bolt (provided) in the large center hole in the base plate of the mailbox. (See Figure 3)
- 4) Thread in by hand and use a Philips head screwdriver to tighten the box to the post.

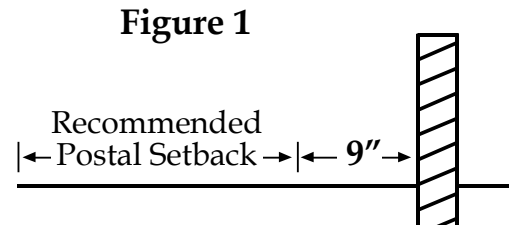
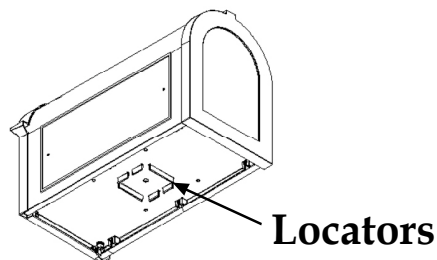

Figure 1

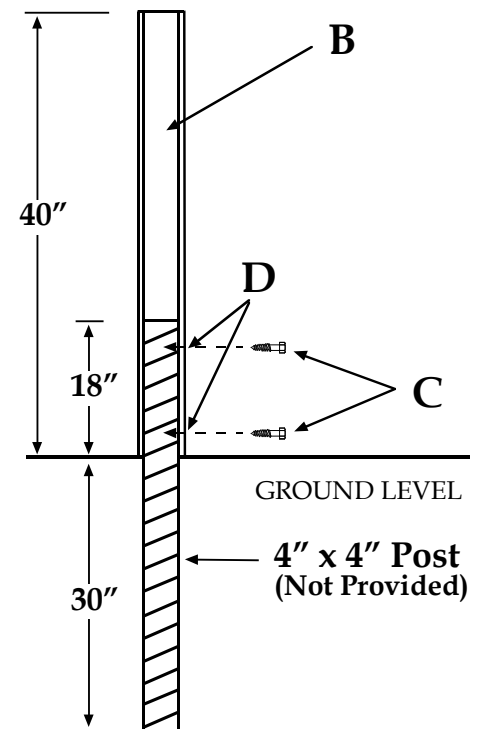

Figure 2

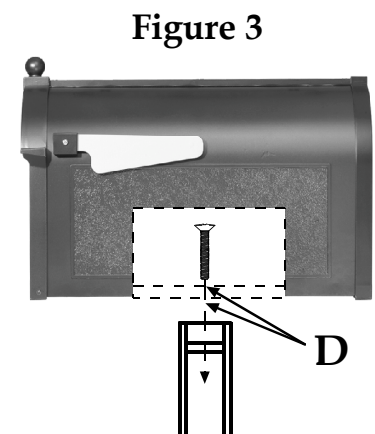
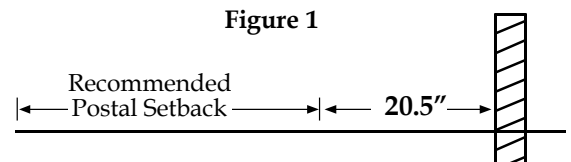

Figure 3

MAILBOX DELUXE POST ASSEMBLY INSTRUCTIONS

Before installing your deluxe mailbox post, consult your local branch of the US post office for road setback requirement and height from roadbed or curb. Post is designed for a 40" average height from ground to base of mailbox.

- A - Mailbox - 1 (Sold Separately)
- B - 54" Deluxe Post - 1
- C - 1/4" Lag Bolts - 2
- D - Mounting Brackets - 2
- E - 10-24 x 1/2 Unfinished Truss Slot Machine Screw - 4
- F - 10-24 x 1/2 Black Anodized Truss Slot Machine Screw - 4
- G - Finial - 1
- H - Tube of Silicon Sealer - 1
- * - Set Screw - 1
- * - Allen Wrench - 1



- 1) Purchase a 4" x 4" x 48" piece of treated lumber from your local lumber yard or home center.
- 2) From post office recommended road setback line add 20.5" and mark position on ground for front edge of post. (See Figure 1)
- 3) Place the 4" x 4" post into the hole so that the face of the post is at the marked line (See step 2) leaving at least 18" out of the ground. (See Figure 2)
- 4) Partially backfill the hole around the post. Use a level make sure the post is vertical then complete the back fill of the post hole packing the earth firmly. Recheck for vertical and adjust if necessary, then repack soil. *Note: For a more permanent installation you may use concrete mix to backfill the hole unless it is against local post office or county road commission guidelines.*
- 5) Carefully remove the aluminum post (B) from the plastic sleeve. To prevent a reaction between the treated wood and aluminum, first slide the plastic sleeve over the partially buried 4x4 and then slide the post down so that the two bolt holes are positioned away from the road and the aluminum post is resting on the ground. (See Figure 2)
- 6) Plumb the aluminum post to vertical and use 2 - 1/4" x 2" lag bolts provided (C) to secure aluminum post to treated post. (See Figure 2 - drilling pilot holes in the wood may be necessary) **Please Note:** Apply small amount of Silicon Sealer (H) in and around holes before securing the two bolts to the post.
- 7) Apply small amount of Silicon Sealer (H) in and around holes on brackets (D) and attach to deluxe post (B) facing the street using 4 -Black Anodized screws (F) provided. (See Figure 3) **DO NOT** tighten screws until mailbox is attached. (if a double mailbox mount is being used, the road set back will be recommended postal set back plus 9", 2 sets of bracket are used and brackets are set parallel with the street)
- 8) Place finial (G) over top of post (B) and, using a rubber mallet, tap finial down firmly on the post.

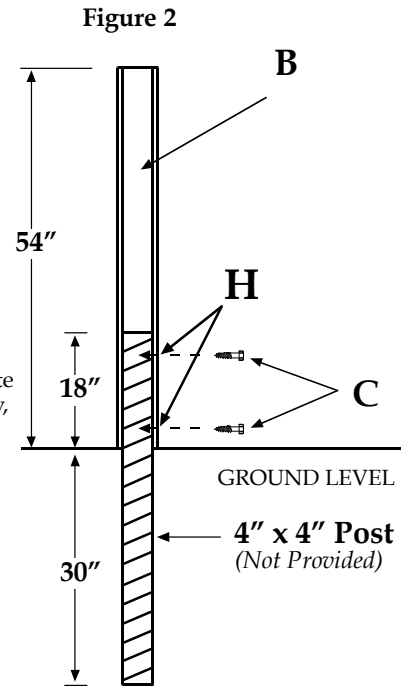

Attaching your mailbox to the deluxe post and brackets:

- 1) Apply a small amount of Silicon Sealer (H) in and around the 4 holes on top of the brackets (D). Place the mailbox (A) on top of the brackets (D) with the back of the box against the post (B) and the box centered over the brackets.
- 2) Using 4 - Unfinished screws (E) provided, reach inside the mailbox and place them thru the 4 holes and into the bracket (threaded holes) and hand tighten. (Loosening the brackets on the post may be necessary to get alignment. If so retighten the brackets to the post once the box is secure).
- 3) Use a flat head screwdriver (not provided) to tighten the 8 screws.

